

This document is the property of Amphenol Corporation and is delivered on the express condition that it is not to be disclosed, reproduced or used, in whole or in part, for manufacture or sale by anyone other than Amphenol Corporation without its prior consent, & that no right is granted to disclose or to use any information in this document.

CUSTOMER DRAWING

REVISIONS				
SYM	ECN	DESCRIPTION	DATE	APPROVED
1	***	FIRST RELEASE	2021/03/07	Michael Ip

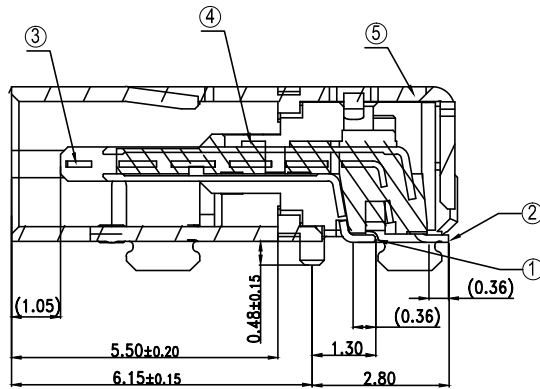
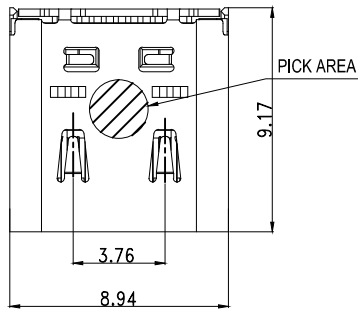

SECTION A-A (剖视图 A-A)
SCALE 2:1 (比例 2:1)

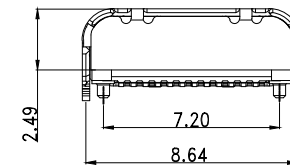
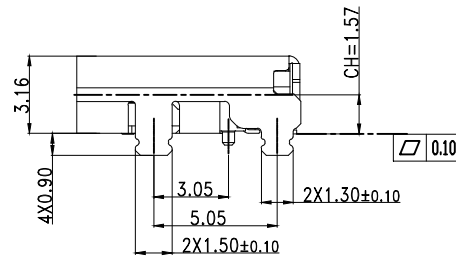
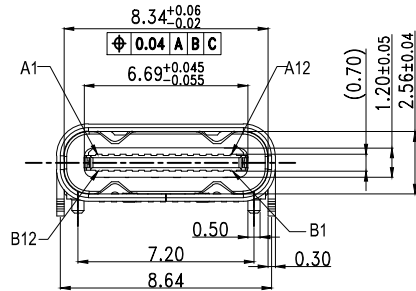
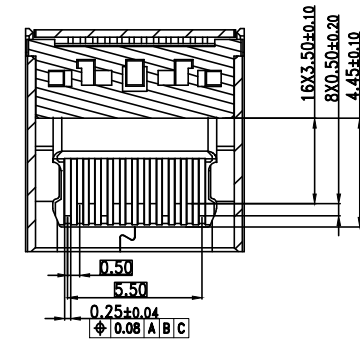

Pin 定义:

	A1	A2	A3	A4	A5	A6	A7	A8	A9	A10	A11	A12
GND	TX1+	TX1-	Vbus	CC1	D+	D-	SBU1	Vbus	RX2-	RX2+	GND	
GND	RX1+	RX1-	Vbus	SBU2	D-	D+	CC2	Vbus	TX2-	TX2+	GND	
	B12	B11	B10	B9	B8	B7	B6	B5	B4	B3	B2	B1

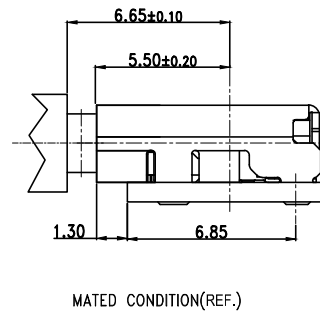
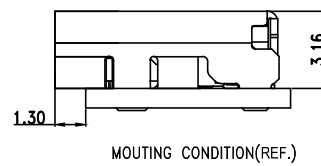
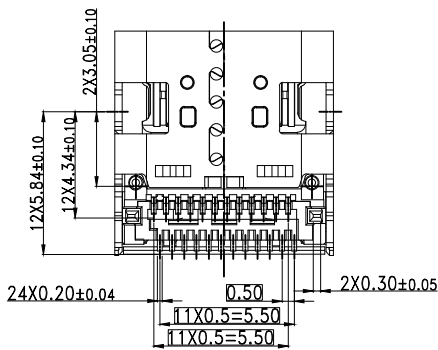

ITEM	DESCRIPTION	Q'TY	MATERIAL	FINISH	REMARK
5	INT SHELL	1	STAINLESS STEEL	NICKEL PLATING	
4	MAIN HOUSING	1	HIGH TEMPERATURE		COLOR:BLACK
3	MID PLATE	1	STAINLESS STEEL		
2	BOTTOM TERMINAL	1	COPPER ALLOY	MATING SIDE:GOLD FLASH; SOLDER TAIL:GOLD FLASH; 30u" NICKEL OVERALL.	
1	TOP TERMINAL	1	COPPER ALLOY		

UNLESS OTHERWISE SPECIFIED TOLERANCES		APPROVAL		DATE
U.S.	METRIC	DRAWN	Val.Wu	08/07/20
.X	+/- 0.50	CHECKED	Michael.Qin	08/07/20
.XX	+/- 0.25	CHECKED	Michael.Qin	
.XXX	+/- 0.10			
FRACTIONS	+/- 3°	DRAWING FILE :		
ANGLES		ANGLE OF PROJECTION		
REMOVE SHARP EDGES		SIZE DRAWING NO.		
DIMENSIONS		12402076		
U.S. INCHES		SCALE NONE SHEET 1 OF 2		
(METRIC) (MM)				

Amphenol
Amphenol East Asia Limited
TITLE Customer Drawing For
USB4 Type C socket connector, R/A , Top mount,
Double SMT type, CH=1.57mm, No Water proof

This document is the property of Amphenol Corporation and is delivered on the express condition that it is not to be disclosed, reproduced or used, in whole or in part, for manufacture or sale by anyone other than Amphenol Corporation without its prior consent, & that no right is granted to disclose or to use any information in this document.

CUSTOMER DRAWING

REVISIONS

SYM	ECN	DESCRIPTION	DATE	APPROVED
SEE PAGE 1				



NOTES/注释:

- MATERIAL/材料:** SEE TABLE/见下表
- GENERAL SPECIFICATION/通用特性:**
 - COPLANARITY /共面度:** 0.10 Max.
 - CURRENT RATING: 5A / 额定电流:** 5安培
 - CONTACT RESISTANCE: 40mΩ MAX (INITIAL). INSULATION RESISTANCE: 100MΩ Min**
接触电阻: 40毫欧最大(初始值) / 绝缘电阻: 100MΩ Min
 - DIELECTRIC WITHSTANDING VOLTAGE: 100 VAC**
耐电压: 100伏交流
 - MECHANICAL CHARACTERISTICS:**
INSERTION FORCE: 5~20N EXTRACTION FORCE: 8~20N
AFTER DURABILITY EXTRACTION FORCE: 6~20N
力学特性: 初始插入力: 5~20N 拔出力: 8~20N
耐久后拔出力: 6~20N
 - DURABILITY: 10000 CYCLES / 耐久性:** 10000次
 - PACKAGING TYPE: CARRIER TAPE./ 包装类型:** 载带包装
- DIMENSIONING SHALL BE INTERPRETED PER ASME Y14.5M 1994.**
尺寸标注基于ASME Y14.5M 1994标准规范
- MATERIAL SHOULD BE FULFILLED AMPHENOL SPEC.# S-SN-002, FOR HALOGEN FREE PRODUCTS, ALSO NEED TO MEET S-SN-004.**
产品材料环保标准为Amphenol SSN#002,如果是无卤产品需满足标准SSN#004
- ORDER P/N SYSTEM/产品料号编码系统:** 12402076E512A

Plating Spec: _____ A:HF
 ES: Mating Area: Au 30u" Min Package Spec.
 Solder Area: Gold flash 2:Reel
 50u"Min Nickel Under Plating Over All Date Code Description
 0:Without D/C
 1:With D/C

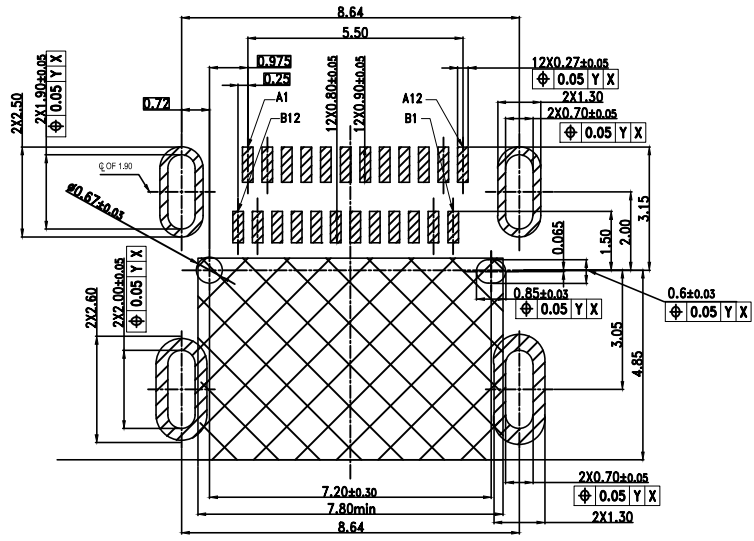

Recommended PCB Layout (Top View)/推荐的PCB布局(前视图)
 General Tolerances: ±0.05 / 一般公差: ±0.05

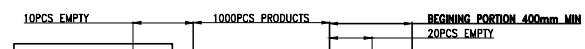

CUSTOMER UNWINDING DIRECTION

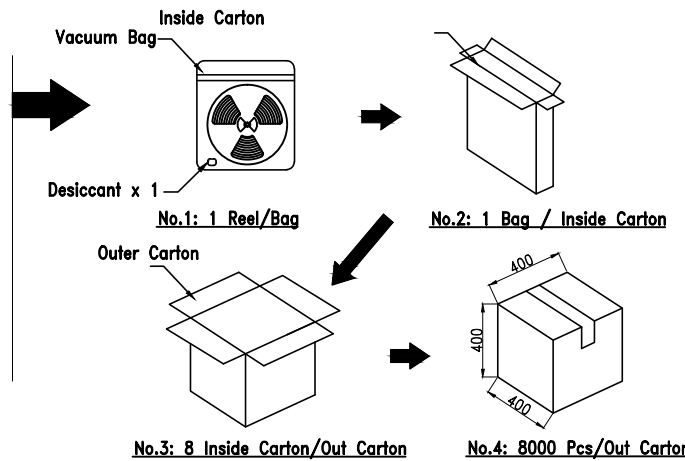
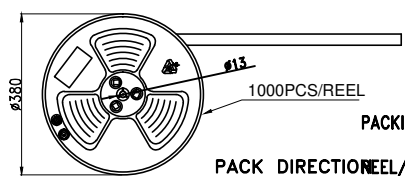

UNLESS OTHERWISE SPECIFIED TOLERANCES		APPROVAL		DATE
U.S.	METRIC	DRAWN	Fai.Wu	06/16/20
.X	+/-	CHECKED	Michael.Qin	06/16/20
.XX	+/-	CHECKED	Michael.Qin	
.XXX	+/-			
FRACTIONS	+/-			
ANGLES	+/-			

Amphenol	
Amphenol East Asia Limited	
TITLE Customer Drawing For	
USB4 Type C socket connector, R/A, Top mount, Double SMT type, CH=1.57mm, No Water proof	
SIZE	DRAWING NO.
A3	12402076
SCALE	NONE
	SHEET 2 OF 2