



- Production test for small sized RF products
- Edge launch testing
- General purpose RF Interconnects through 18 Ghz

SilverLine®-ExtraFlex was designed for testing delicate components such as exposed RF circuits with edge launch connectors. Thin, lightweight and flexible this coax makes handling PC boards easy yet does not compromise RF stability and isolation. Using Times' proprietary TF-4 dielectric SilverLine®-ExtraFlex goes one step further, exhibiting linear phase change from 0°C to +30°C (see graph).

SilverLine®-ExtraFlex uses the same robust, proven connector attachment system that has made SilverLine® the preferred choice in RF test labs everywhere. A new injection-molded strain relief system designed to match the cable's flexibility assures the cable will bend tightly but not fail prematurely behind the connector.

**Features and Benefits:**

- 30% smaller than Standard SilverLine®
- Improved Flexibility
- RF Stable With Flexure
- Better than -90dB Isolation
- 18 Ghz operation
- Linear Phase Change From 0° to 30°C
- Injection-Molded Strain Relief

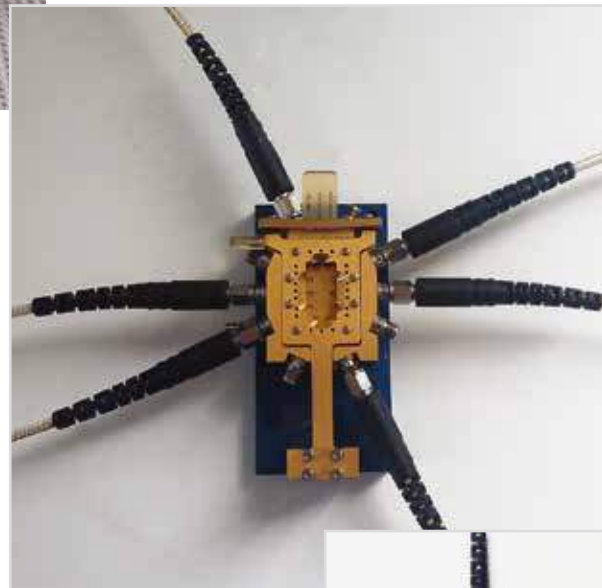

Test fixture photo courtesy of Inter-Continental Microwave [www.icmicrowave.com](http://www.icmicrowave.com)

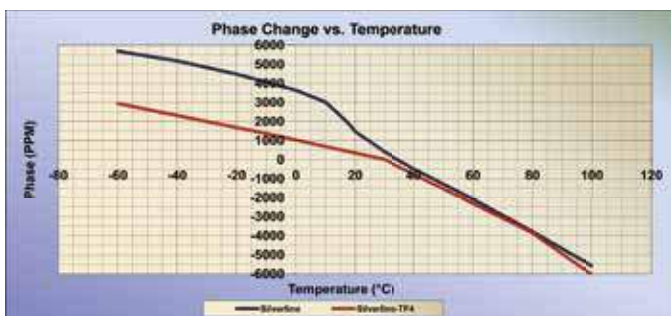
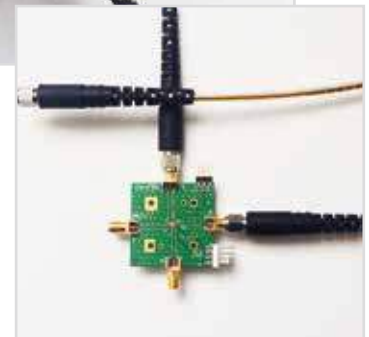

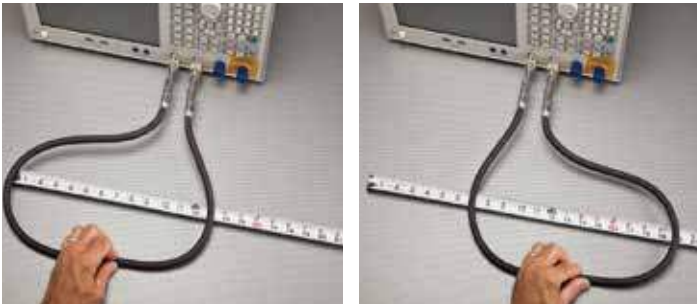

\*\* Phase and amplitude stability data IAW Times' phase/flex test criteria as demonstrated above.

### Connectors:

- Stainless steel
- Solder/Clamp attachment
- Captive contact construction

\* Mating life assumes the use of a calibrated torque wrench, interfaces are clean and within mil specs limits.

Mechanical Specifications		
Dimensions	in	mm
Armored Diameter	0.15	3.80
Min bend radius (max flex life)	0.75	19
Mating life cycle *	5000	
Flex life	50,000 cycles	
Temperature range	-67°/+ 257 °F -55°/+125 °C	
Electrical Specifications		
Impedance	50 Ohms	
Velocity of Propagation	70%	
Shielding Effectiveness	>-90 dB	
VSWR (maximum)	18 GHz	
	1.35:1	
Phase Stability (degrees) **	max	+/-1.5°
Amplitude Stability (dB)**	max	+/-0.05
Attenuation, max@77°F (25°C)	dB/100 ft	(dB/100 m)
1 GHz	16	52
2 GHz	24	79
6 GHz	45	148
12 GHz	66	216
18 GHz	85	279

Specifications subject to change without notice.

### Ordering Information:

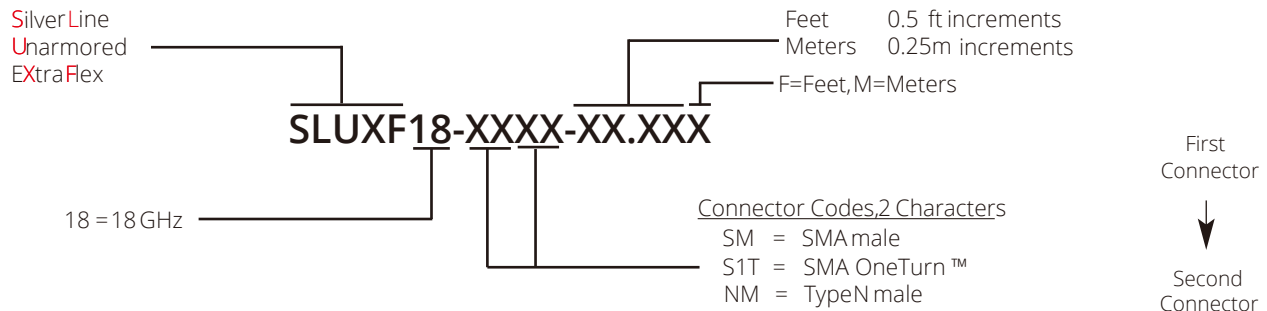

A brand new cable can have a break-in period of several hundred flexes.

#### World Headquarters:

358 Hall Avenue, Wallingford, CT 06492 Fax: 203-949-8423

Tel: 203-949-8400, 1-800-867-2629 International: 203-949-8503



TMC Building 4, No. 318 Yuanshan Road, Xinzhuang Industrial Park, Shanghai, China 201108 Tel: 86-21-5176-1209 Fax: 86-21-64424098