

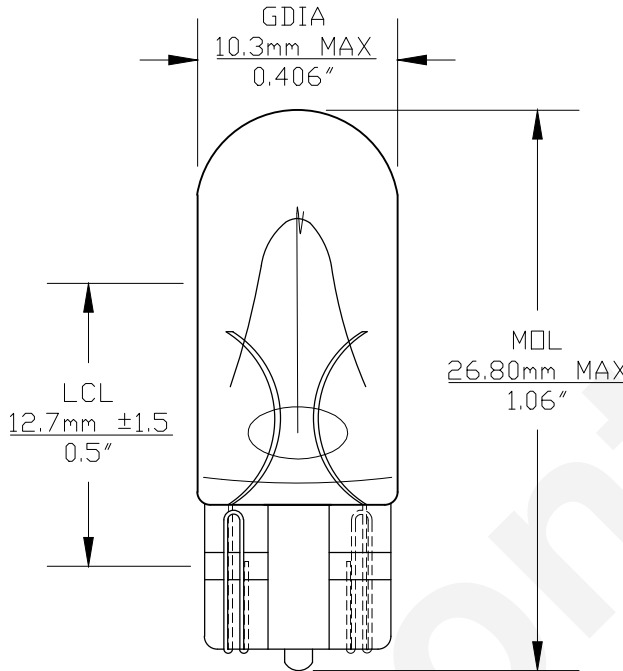

PART NO.	BASE TYPE	DESIGN VOLTS	DESIGN AMPS	MSCD	FILAMENT TYPE	AVERAGE LIFE HOURS	REVISIONS			
							REV #	DESCRIPTION	DATE	APPROVED
2825	Glass Wedge T-3 1/4 (W2.1X9.5d)	12.0V	0.40	4.0	C-2V	300	1	ISSUED	04/27/2005	D.C.
							2	ECE SPECIFICATION	07/01/2009	D.C.

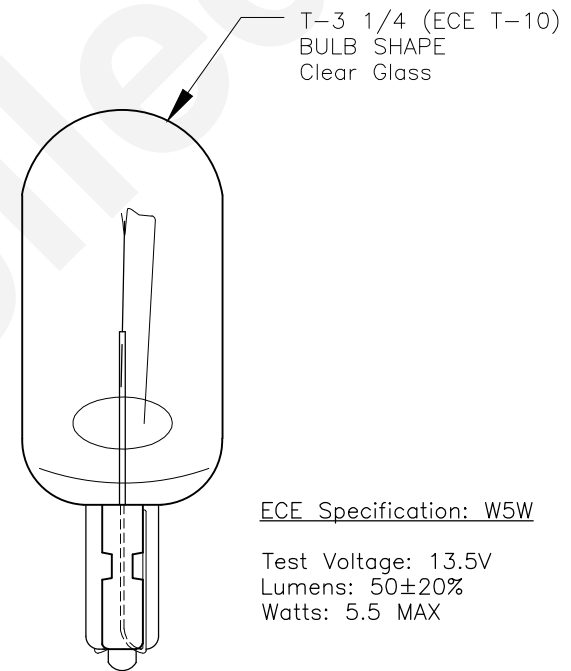

0° VIEW



90° VIEW

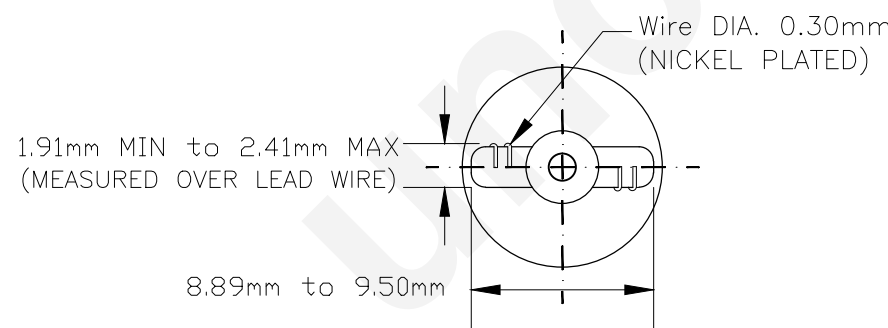

BASE BOTTOM VIEW



Note: Made according to ECE/R37 specifications

UNLESS OTHERWISE SPECIFIED: DIMENSIONS ARE IN INCHES TOLERANCES		CEC INDUSTRIES LTD	
DECIMALS	ANGULAR	599 BOND STREET LINCOLNSHIRE, IL 60069	
.XX ± .05	± 0.5°		
.XXX ± .010			
FRACTIONAL	± 1/64		
DRAWN D. C.	DATE 04/27/2005	TITLE LIGHT BULB NO. 2825 (W5W)	
CHECKED	SIZE A	FSCM NO.	DWG NO. 2825
DESIGN	SCALE	PLOT SCALE	REV 2
MATERIAL	FILE 2825.pdf	SHEET 1 OF 1 DRAWING NOT TO SCALE	