

MHz RANGE CRYSTAL UNITS (PLASTIC SURFACE MOUNT TYPE)

CM309A/CM309B (1,000pcs/reel)

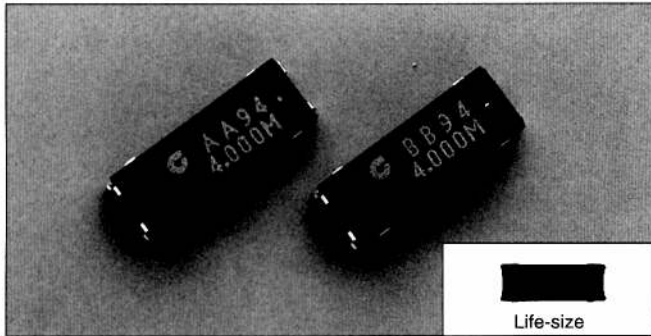

■ DIMENSIONS: (UNIT=mm)

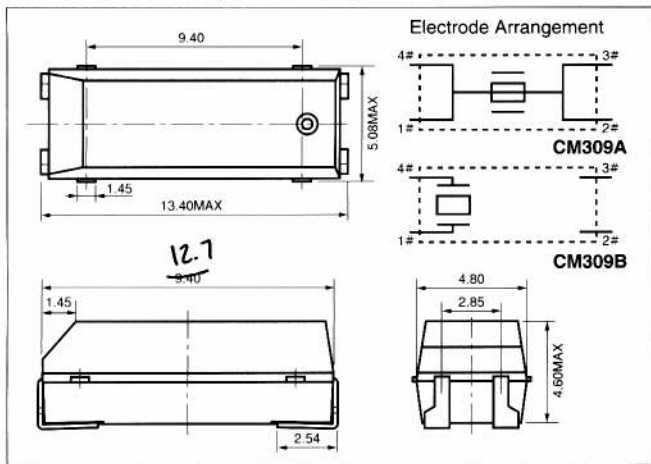

■ FEATURES:

- Being of the miniature SMD type and featuring high efficiency in mounting, the CM309S is ideal for application to high-density circuit boards.
- As it incorporates a heat-resisting packaged cylinder-type crystal, this crystal makes best use of the superb characteristic AT-cut crystals have, and permits reflow soldering.
- Enables automatic mounting, due to the adoption of the emboss taping packaging.

■ APPLICATIONS:

- Can be used for a wide range of applications including use in communication equipment, AV equipment, OA equipment and measuring instruments.

■ RECOMMENDED SOLDERING PATTERN: (UNIT=mm)

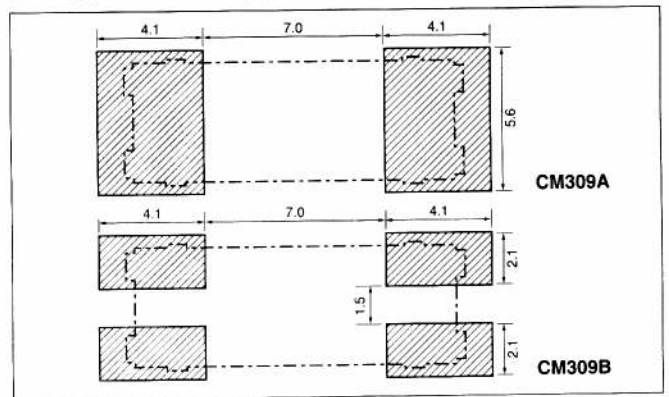

■ STANDARD SPECIFICATIONS

Item	Model	CM309A/CM309B	Conditions
Nominal frequency	f_0	3.5MHz~32MHz (fund), 30MHz~70MHz (3rd OT)	Please contact us for changes in frequency.
Frequency tolerance	$\Delta f/f_0$	± 30 ppm or ± 50 ppm	At 25°C
Frequency vs. Temperature characteristics	$\Delta f/f_0$	± 50 ppm (± 30 ppm)	-10°C~+60°C
Operating temperature range	T_{ORP}	-40°C~+85°C	
Storage temperature range	T_{STG}	-55°C~+125°C	
Equivalent series resistance	R_1	See drawing	At 25°C
Load capacitance	C_L	16pFTYP	Please specify
Shunt capacitance	C_0	7.0pF MAX.	
Drive level	DL	50 μ W~100 μ W	
Insulation resistance	IR	500M Ω MIN.	DC100V \pm 15V
Aging (First year)	$\Delta f/f_0$	± 5 ppm MAX.	25°C \pm 3°C
Sealing		1 x 10 ⁻² μ Pa·m ³ /s MAX.	
Shock resistance		± 5 ppm MAX. Drop test of 3 times on a hard board from 75cm height or shock test of 3000G x 0.3ms x 1/2 sin wave x 3 directions	Conditions will vary depending on the frequency.

FREQUENCY vs TEMPERATURE CURVE

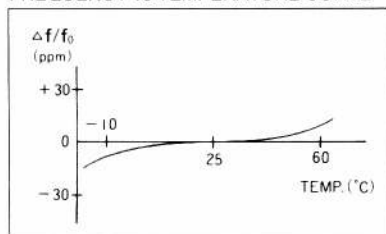

EQUIVALENT SERIES RESISTANCE (ESR, R₁)

Frequency	Equivalent series resistance	Mode
3.5MHz \leq f_0 < 4MHz	200	fundamental
4MHz \leq f_0 < 6MHz	150	
6MHz \leq f_0 < 10MHz	100	
10MHz \leq f_0 \leq 32MHz	50	
30MHz < f_0 < 36MHz	100	3rd OT
36MHz \leq f_0 < 70MHz	80	

(Ω MAX.)