

THIS INFORMATION IS CONFIDENTIAL AND IS DISCLOSED TO YOU ON CONDITION THAT YOU WILL NOT DISCLOSE IT TO OTHER THAN AMP PERSONNEL WITHOUT WRITTEN AUTHORIZATION FROM AMP INCORPORATED, PITTSBURGH, PA.

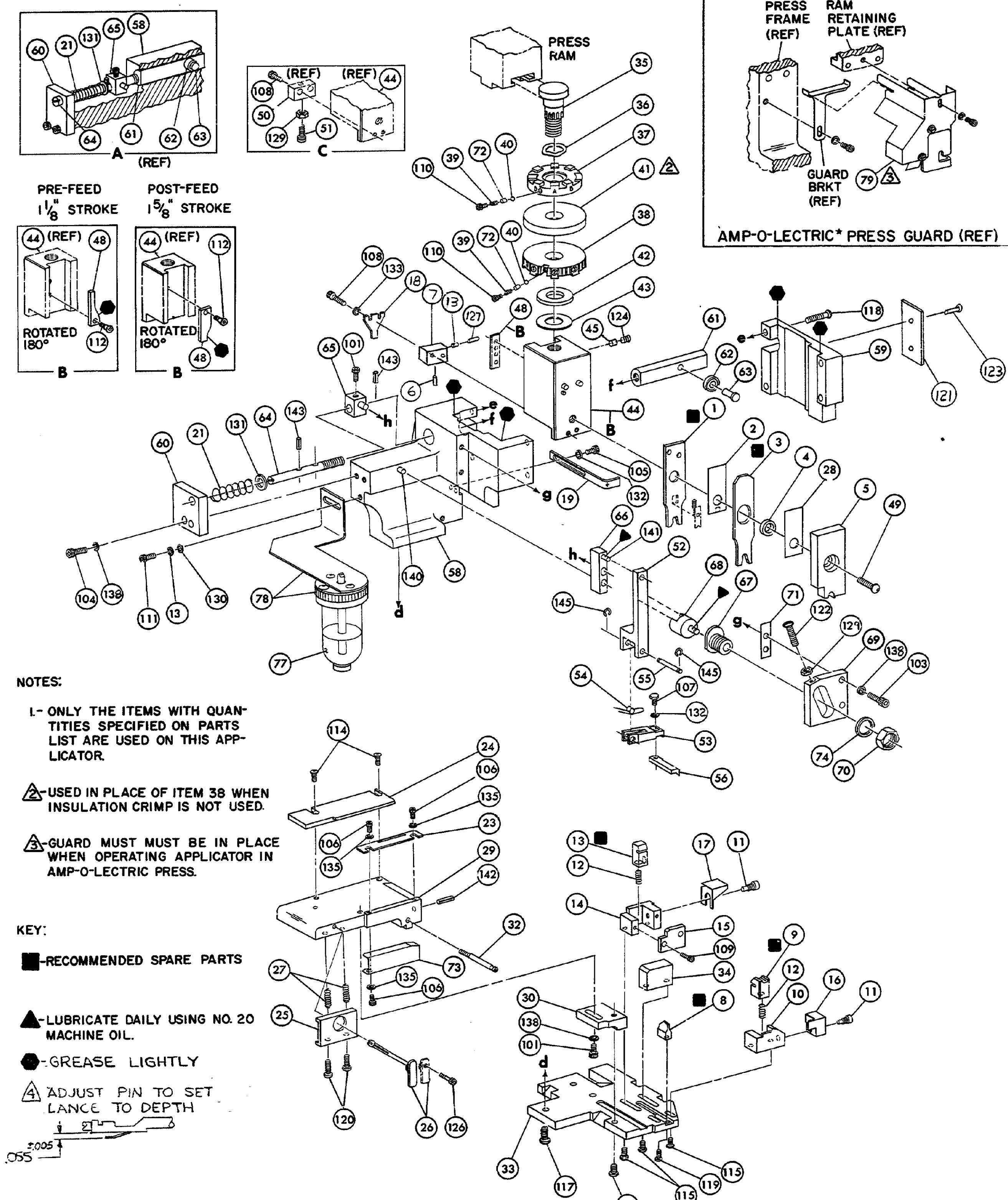

- NOTES:**
- I- ONLY THE ITEMS WITH QUANTITIES SPECIFIED ON PARTS LIST ARE USED ON THIS APPLICATOR.
 - ▲ USED IN PLACE OF ITEM 38 WHEN INSULATION CRIMP IS NOT USED.
 - ▲ GUARD MUST BE IN PLACE WHEN OPERATING APPLICATOR IN AMP-O-LECTRIC PRESS.
- KEY:**
- - RECOMMENDED SPARE PARTS
 - ▲ - LUBRICATE DAILY USING NO. 20 MACHINE OIL.
 - - GREASE LIGHTLY
 - △ - ADJUST PIN TO SET LANCE TO DEPTH

QTY	PART NO	DESCRIPTION	ITEM NO	QTY	PART NO	DESCRIPTION	ITEM NO
2	21045-3	RING, RETAINING 'C' (.187 DIA) FEED FINGER PIN	145	1	454220-1	CAP, HOUSING	59
2	5-21028-1	PIN, SLOT SPR (.125 DIA X .50) ADJ ROD	143	1	454485-1	HOUSING	58
1	4-21028-0	PIN, SLOT SPR (.093 DIA X .75) STR G PLATE	142	1	458537-1	PAWL, FEED	56
1	1-21030-1	PIN, DOWEL (.187 DIA X .50) LEVER	141	1	240624-1	PIN, FEED FINGER	55
1	1-21030-6	PIN, DOWEL (.187 DIA X 1.25) HOUSING	140	1	691499-1	SPRING, FEED FINGER	54
1	21024-5	WASHER, LOCK (NO 10) LUB ASSY	139	1	690541-1	FINGER, FEED	53
5	21024-5	WASHER, LOCK (NO 10) STRIP GUIDE ADJ BLOCK	138	1	455679-2	LEVER, TERMINAL FEED ARM	52
2	21024-5	WASHER, LOCK (NO 10) ADJ PLATE	137			BUMPER, HOLDDOWN	51
2	21024-5	WASHER, LOCK (NO 10) FEED GUIDE ROD	136			SPACER, TONKER	50
2	21024-2	WASHER, LOCK (NO 4) FRONT STRIP GUIDE	135	1	7-21002-9	BOLT, CRIMPER	49
1	21024-4	WASHER, LOCK (NO 8) FEED FINGER	134	1	690501-4	CAM, POST FEED 1 5/8 STROKE	48
2	21024-4	WASHER, LOCK (NO 8) DEPRESSOR	133				47
4	21024-4	WASHER, LOCK (NO 8) STRIPPER	132		459456-1	APPLICATOR, BASIC (SUB ASSY)	46
1	21899-4	WASHER, FLAT (5/16 DIA) SCREW ADJ	131	1	690191-1	PLUG, NYLON	45
1	21899-2	WASHER, FLAT (NO 10) LUB ASSY	130	1	455673-1	RAM	44
2	21018-5	NUT, HEX MACH (6-32) HOLDDOWN	129	1	690125-1	WASHER, LAMINATED	43
1	21068-5	NUT, HEX MACH (6-32) FEED ADJ	128	1	690124-1	WASHER, RAM	42
1	2-21006-1	SCR, SKT SET (4-40 X .25) PIN HOLDER	127			DISC, SPACER	41
1	22353-8	SCR, SHLD. (.187 DIA X .250 LG) DRAG LEVER	126	2	23241-6	BALL, STEEL	40
			125	2	690170-1	SPRING, COMPRESSION	39
1	21009-2	SCR, SKT SET (1/4-20 X .25) (LOC-WEL) RAM	124	1	690142-5	DISC, INSULATION	38
2	21017-2	SCR, DRIVE (#2 X .19) I. D. PLATE	123	1	7-690141-6	DISC, WIRE	37
1	6-23715-5	SCR, RD HD MACH (6-32 X 1.50) FEED ADJ	122	1	22480-5	WASHER, SPRING	36
1	461264-1	PLATE, IDENTIFICATION	121	1	690212-1	POST, RAM	35
2	2-21002-9	SCR, BUT HD SKT CAP (10-32 X .75) DRAG	120		694074-5	SUPPORT, TERM:NAL	34
1	22733-8	SCR, BUT HD SKT CAP (8-32 X .38) (LOC-WEL) ANVIL	119	1	455675-1	PLATE, BASE	33
4	2-21002-9	SCR, BUT HD SKT CAP (10-32 X .75) CAP	118	1	690432-3	SCREW, ADJUSTMENT	32
3	222733-8	SCR, BUT HD SKT CAP (1/4-20 X .75) HOUSING	117				31
1	2-21002-7	SCR, BUT HD SKT CAP (10-32 X .50) SG ADJ BLOCK	116	1	455689-1	BLOCK, STRIP GUIDE ADJ	30
4	2-21002-2	SCR, BUT HD SKT CAP (8-32 X .50) SHEAR	115	1	458144-9	PLATE, STRIP GUIDE	29
2	2-21002-3	SCR, BUT HD SKT CAP (8-32 X .62) R STRIP GUIDE	114	1	1-455888-2	SPACER, FRONT SHEAR DEPRESSOR	28
			113	2	1-22284-0	SPRING, DRAG	27
1	1-21002-7	SCR, BUT HD SKT CAP (6-32 X .38) CAM	112	1	240793-1	LEVER, DRAG RELEASE	26
1	3-21000-4	SCR, SKT HD CAP (10-32 X .38) LUBRICATOR ASSY	111	1	240792-1	DRAG, STOCK	25
2	23030-1	SCR, SKT HD CAP (6-32 X .25) (LOC-WEL) CP DISC	110	1	5-690504-8	GUIDE STRIP (REAR)	24
			109	1	690438-1	GUIDE, STRIP (FRONT)	23
2	2-21000-8	SCR, SKT HD CAP (8-32 X .62) DEPRESSOR	108				22
1	2-22603-0	SCR, HEX HD MACH (8-32 X .31) FEED FINGER	107	1	4-22284-9	SPRING, FEED RETURN	21
3	1-21000-3	S. I, SKT HD CAP (4-40 X .25) F STRIP GUIDE	106				20
1	2-21000-7	SCR, SKT HD CAP (8-32 X .50) STRIPPER	105	1	690472-2	STRIPPER	19
2	3-21000-7	SCR, SKT HD CAP (10-32 X .75) FEED ROD GUIDE	104	1	469965-1	HOLDER, TERMINAL	18
2	3-21000-6	SCR, SKT HD CAP (10-32 X .62) FEED ADJ BLOCK	103			GUARD, CHIP (REAR)	17
1	3-21000-4	SCR, SKT HD CAP (10-32 X .38) SG ADJ BLOCK	102	1	691667-3	GUARD, CHIP (FRONT)	16
2	3-21000-4	SCR, SKT HD CAP (10-32 X .38) PIVOT BLOCK	101			PLATE, SHEAR (REAR)	15
REF.	455755-3	GUARD ASSY	79			HOLDER, SHEAR (REAR)	14
1	1-465184-0	LUBRICATOR ASSY	78	1	690191-5	PLUG, NYLON	13
		OIL, LUBRICATING	77	1	5-22280-0	SPRING, SHEAR	12
			76	1	690461-1	STOP, SHEAR	11
			75	1	690459-1	HOLDER, SHEAR (FRONT)	10
1	458109-1	WASHER, SPECIAL	74	1	454276-2	SHEAR, FLOAT (FRONT)	9
1	454877-3	PLATE, STRIP GUIDE COVER	73	1	3-458834-9	ANVIL	8
2	690603-1	SPRING, ASSIST	72	1	815306-1	HOLDER, SETTING PIN	7
1	690517-1	SPACER	71	1	815307-1	PIN, LANCE SETTING	6
1	22594-8	NUT, HEX	70	1	2-455889-2	DEPRESSOR, SHEAR (FRONT)	5
1	240628-1	PLATE, ADJUSTMENT	69	1	238011-2	SPACER, TUBULAR, INS CRIMPER	4
1	240626-1	SHAFT, PIVOT	68	1	4-456135-9	CRIMPER, INSULATION	3
1	240633-1	BUSHING	67	1	1-455888-0	SPACER, CRIMPER	2
1	455680-1	LEVER, INTERMEDIATE	66	1	458141-6	CRIMPER, WIRE	1
1	240629-1	BLOCK, PIVOT	65				
1	240632-2	SCREW, ADJUSTMENT FEED ROD	64				
1	240659-3	PIN, CAM ROLLER	63				
1	240658-1	ROLLER, CAM	62				
1	454398-2	ROD, FEED	61				
1	454178-1	GUIDE, FEED ROD	60				

CRIMPING DATA				APPLICATOR WILL APPLY					
PAD LTR	CRIMP HEIGHT	WIRE SIZE	WIRE STRIP LENGTH	530517					
A	.086	14							
B	.077	16							
C	.072	18							
D	NOT USED								
CRIMP	SIZE	TYPE	FEED	APPL INST					
WIRE	.110	"F"							
INSUL	.180	"O"	.750	A1	8040				
WIRE RANGE	18-14	INSULATION RANGE	.390-.145	PRESS NO					
REMARKS									
AMPOMATOR POST FEED									
I. D. PLATE (REF): 461264-1									
<table border="1"> <tr> <td>NO</td> <td>REV</td> </tr> <tr> <td>1</td> <td>1</td> </tr> </table>						NO	REV	1	1
NO	REV								
1	1								
APPL USED ON MACHINE PART NO		MACH SERIAL NO		DISTRIBUTION					
CUSTOMER NAME		APPL SERIAL NO		ORIGINAL					
ADDRESS		PURCHASE ORDER		CUSTOMER COPY					
CITY		ENG APP		FIELD ENG COPY					

PI/LTR	REVISION RECORD	APP DATE	PI/LTR	REVISION RECORD	APP DATE