

THIS DRAWING IS A CONTROLLED DOCUMENT FOR SOURIAU USA, INC. IT IS SUBJECT TO CHANGE WITHOUT NOTIFICATION. CONTACT THE DOCUMENT CONTROL CENTER FOR THE LATEST REVISION.

DWG. NO. **JBXFDIC**

ELECTRICAL:
 EMI SHIELDING : SHIELDED FOR THE RANGE 55dB UP TO 100MHZ
 INSULATION RESISTANCE : >500MΩ PER ANSI-EIA-364-D METHOD 21
 MAX. CURRENT RATING : SEE INSULATOR DRAWING
 CONNECTOR TESTING VOLTAGE : SEE INSULATOR DRAWING
 CONNECTOR WORKING VOLTAGE : SEE INSULATOR DRAWING

PHYSICAL:
 MAXIMUM WIRE SIZE USED : SEE INSULATOR DRAWING
 CABLE DIAMETER WITH PLASTIC COLLET SET SUPPLIED: Ø2.0 mm MIN. TO Ø7.5mm MAX.

ENVIRONMENTAL:
 ENDURANCE: 1000 CYCLES AS PER MIL-STD 1344A, METHOD 2016.1
 SHOCK: 50 g , DURATION 6 ms; AS PER MIL-STD 1344A, METHOD 2004.1
 VIBRATIONS: 10 TO 2000Hz g = 15g, AS PER MIL-STD 1344A, METHOD 2005.1
 PROTECTION INDEX: IP 40 AS PER CEI 529
 ROHS COMPLIANT
 SALT MIST : 48Hr PER SAE AS 1344 METHOD 1001.1 CEI 529
 OPERATING TEMPERATURE:
 WITH PLASTIC COLLETS: -55°C TO +125°C (-67°F TO +257°F)
 WITH OPTIONAL METALLIC COLLETS: -55°C TO +200°C (-67°F TO +392°F) (ONLY ON REQUEST)

NOTES:
 1 ▷ RED DOT.
MATERIAL:
 OUTER SHELL & BACK NUT : } BRASS
 LATCHING SLEEVE : }
 HALF BUSHES : }
 COLLET : POLYAMIDE
FINISH:
 OUTER SHELL & BACK NUT : CHROME
 OTHER BRASS PARTS : NICKEL
 T ▷ TOOLS

MASS (g)	VOLUME (mm ³)
14.6	2584

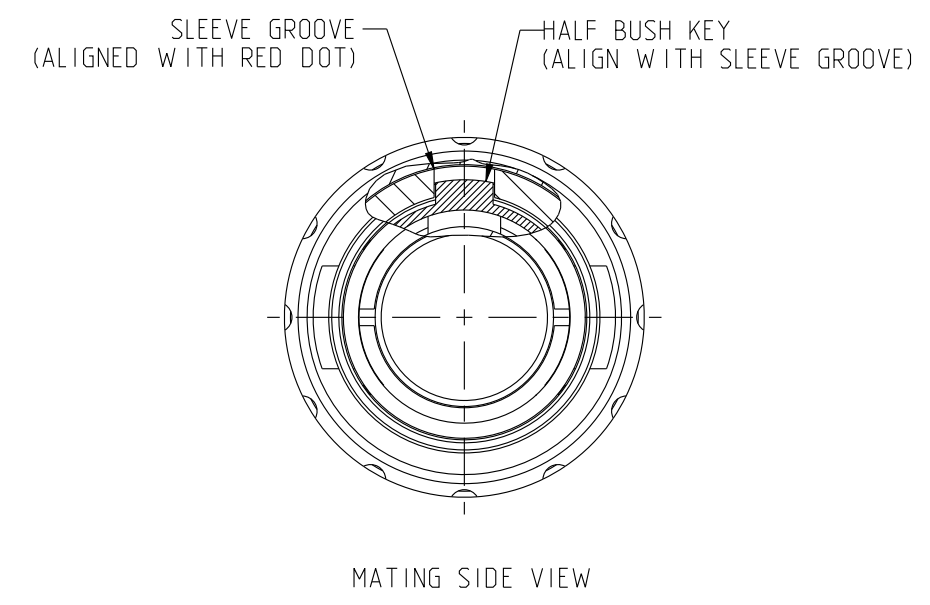
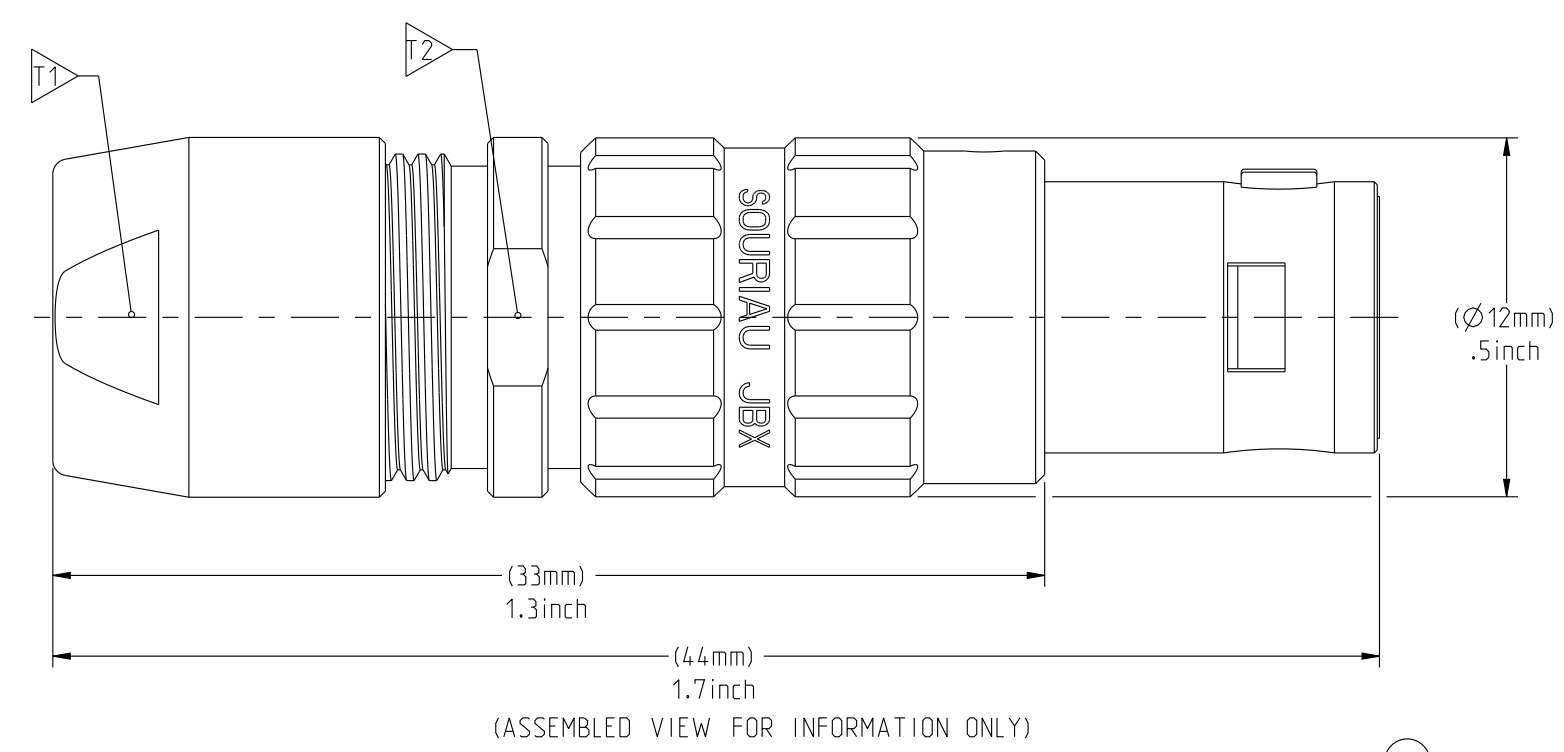
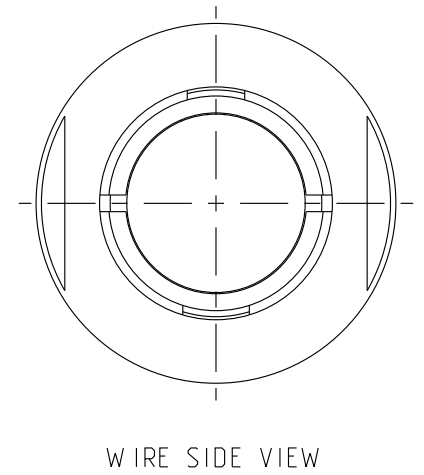

PART LIST	
ITEM NO.	DESCRIPTION
1	SLEEVE
2	HALFBUSH WITH WINDOW
3	HALFBUSH WITHOUT WINDOW
4	INSULATOR
5	Ø2.0-Ø7.5 CABLE COLLET (CHOOSE PER CABLE SIZE)
6	STANDARD BACK NUT
6a	BACK NUT FOR PROTECTIVE BOOT (OPTIONAL)

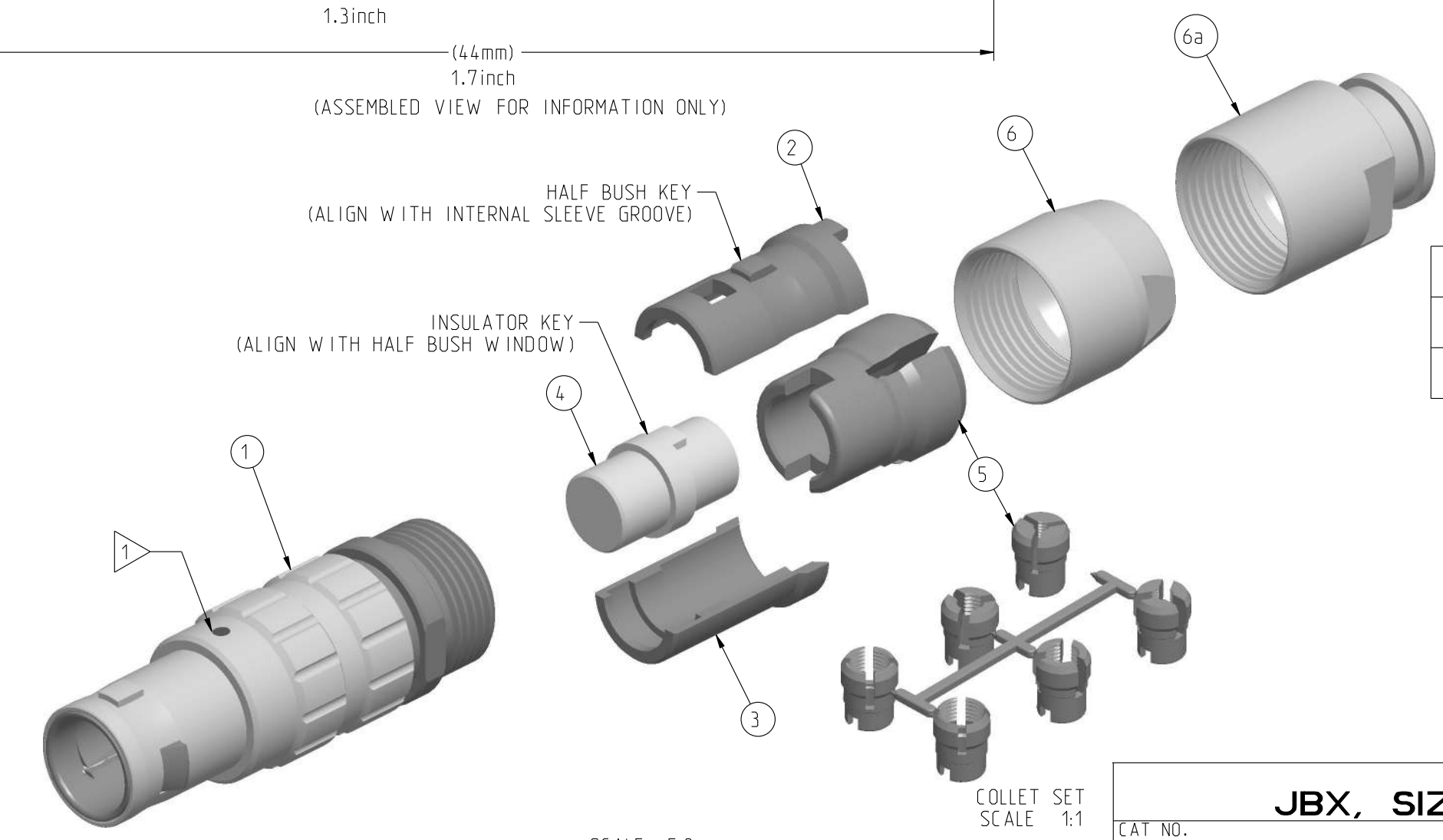

	TOOLS (JAW DIMENSION)	ADVISED TORQUE IN Nm
T1	10	1
T2	11	-

CATALOG NUMBER DESCRIPTION

JBX FD 1 XXXXXDXX

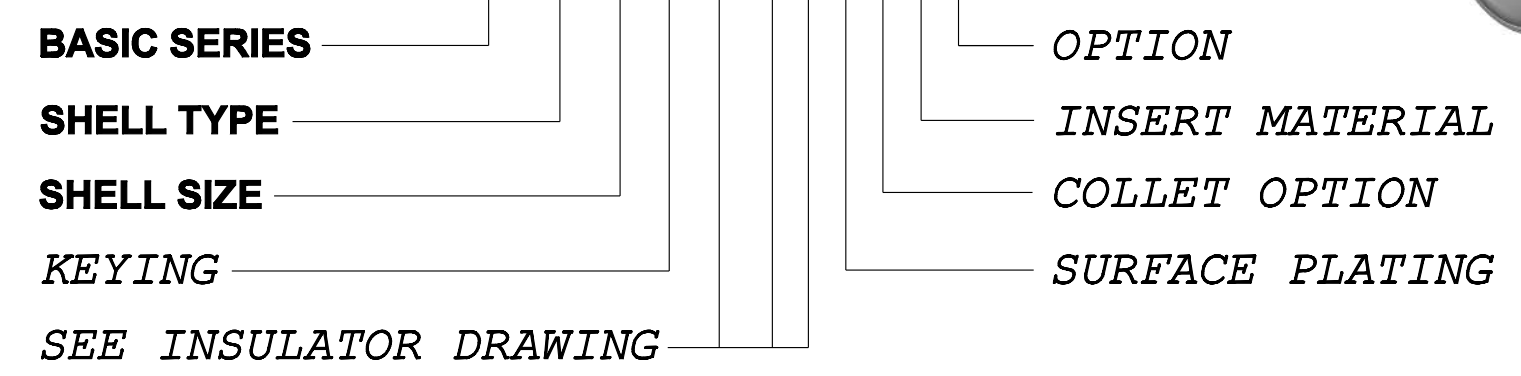

ORIGIN	COUNTRY	JURISDICTION	CLASSIFICATION
X	FR	Not listed	N/A
	US	EAR	ECCN =EAR99

These commodities, technology or software are exported from the United States in accordance with the Export Administration Regulations. Diversion contrary to U.S. law is prohibited.

LINEAR MEASURE:	mm (mm)	inch (INCH)
THIRD ANGLE PROJECTION		
TOLERANCES UNLESS OTHERWISE SPECIFIED		
No. OF PLACES	mm [INCH]	
WHOLE No.	±0.5 [±.02]	
ONE PLACE	±0.2 [±.008]	
TWO PLACES	±0.1 [±.004]	
ANGLES ±1°		

DRAWING TITLE JBX, SIZE 1, STRAIGHT PLUG		APPROVAL	
CAT NO.	JBXFD1	DRAWN: TJS	01-07-15
CAGE NO: 09922	SIZE: C	CHKD: EV	01-07-15
CUSTOMER		DSGN: EV	01-07-15
		MFG: DH	01-07-15
INTERPRET THIS DRAWING IN ACCORDANCE WITH ASME Y14.5M - 1994.		QC: BB	01-07-15
		DRAWING SCALE: 4:1	
www.souriau.com		DRAWING NO. REV	
		JBXFDIC A	
		1 OF 1	

THE INFORMATION CONTAINED IN THIS DRAWING IS CONFIDENTIAL AND MAY NOT BE DISCLOSED WITHOUT WRITTEN CONSENT FROM SOURIAU USA, INC.

DWG. NO.
JBX11NSMCC

MALE INSULATOR, CRIMP CONTACT

CONTACT LAYOUT	02	03	04	05
FRONT SIDE VIEW				
REAR SIDE VIEW				
CONTACT				
ISO VIEW				
CONTACT	ØC	1.3	1.3	0.9
	ØF	1.4	1.4	1.1
	MAX. AWG	18	18	20
	MAX. CURRENT RATING (A)	15	15	10
INSULATOR	CONTACT RESISTANCE (mΩ)	3	3	3.5
	NUMBER OF CAVITY	2	3	4
	MAX. CURRENT RATING	15	12	10
	TEST VOLTAGE (Vrms)	1600	1300	1900
WORKING VOLTAGE (Vdc/Vrms)	760/530	600/420	900/630	660/460

CONTACT TYPE : M (MALE)
CONTACT TERMINATION : C (CRIMP)
MATERIAL :
 CONTACT: BRASS
 CLIP: COPPER ALLOY
 INSULATOR: PEEK
FINISH:
 CONTACTS: GOLD

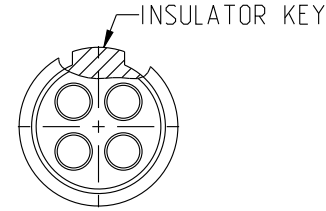

CATALOG NUMBER DESCRIPTION

JBXXX 1 XYYM CXXXX

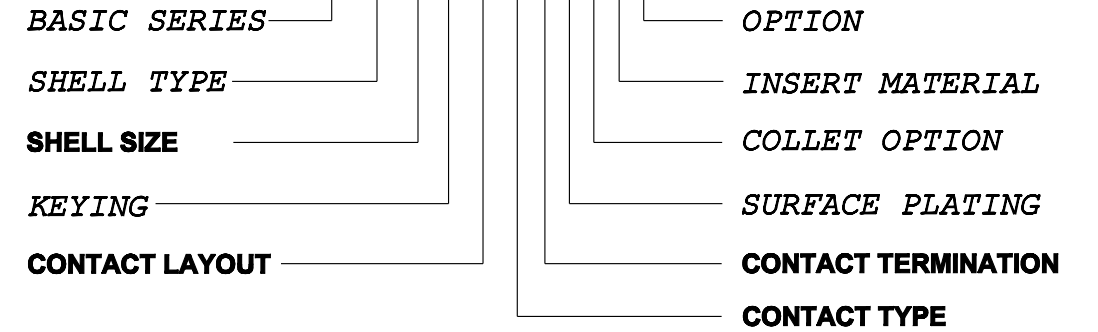

B	REVISED PER ECN 12286	RSK 06-10-15	EV 06-10-15
A	RELEASED PER ECN 12264	SKV 03-10-15	EV 03-10-15
REV	DESCRIPTION	BY DATE	CHKD DATE

DRAWING TITLE
JBX, SIZE 1, MALE INSULATOR, CRIMP CONTACT

CAT NO. **JBX11NSMC**

CAGE NO: 09922 SIZE: B

CUSTOMER	SOURIAU	APPROVAL	DRAWN: SKV 02-02-15
		CHKD : EV 02-02-15	
INTERPRET THIS DRAWING IN ACCORDANCE WITH ASME Y14.5M - 1994.	WWW.SOURIAU.COM	DSGN : EV 02-02-15	DRAWING SCALE: NA
		MFG : DH 02-02-15	DRAWING NO. REV
		QC : BB 02-02-15	JBX11NSMCC B
			1 OF 2

ORIGIN	COUNTRY	JURISDICTION	CLASSIFICATION
X	FR	Not listed	N/A
	US	EAR	ECCN =EAR99

These commodities, technology or software are exported from the United States in accordance with the Export Administration Regulations. Diversion contrary to U.S. law is prohibited

LINEAR MEASURE: $\frac{mm}{INCH}$ mm (INCH)
 THIRD ANGLE PROJECTION

 TOLERANCES UNLESS OTHERWISE SPECIFIED
 No. OF PLACES mm [INCH]
 ONE PLACE ±3 [±.1]
 TWO PLACES ±0.5 [±.02]
 THREE PLACES ±0.25 [±.010]
 ANGLES ±1°

THIS DRAWING IS A CONTROLLED DOCUMENT FOR SOURIAU USA, INC. IT IS SUBJECT TO CHANGE WITHOUT NOTIFICATION. CONTACT THE DOCUMENT CONTROL CENTER FOR THE LATEST REVISION.

THE INFORMATION CONTAINED IN THIS DRAWING IS CONFIDENTIAL AND MAY NOT BE DISCLOSED WITHOUT WRITTEN CONSENT FROM SOURIAU USA, INC.

DWG. NO.
JBX11NSMCC

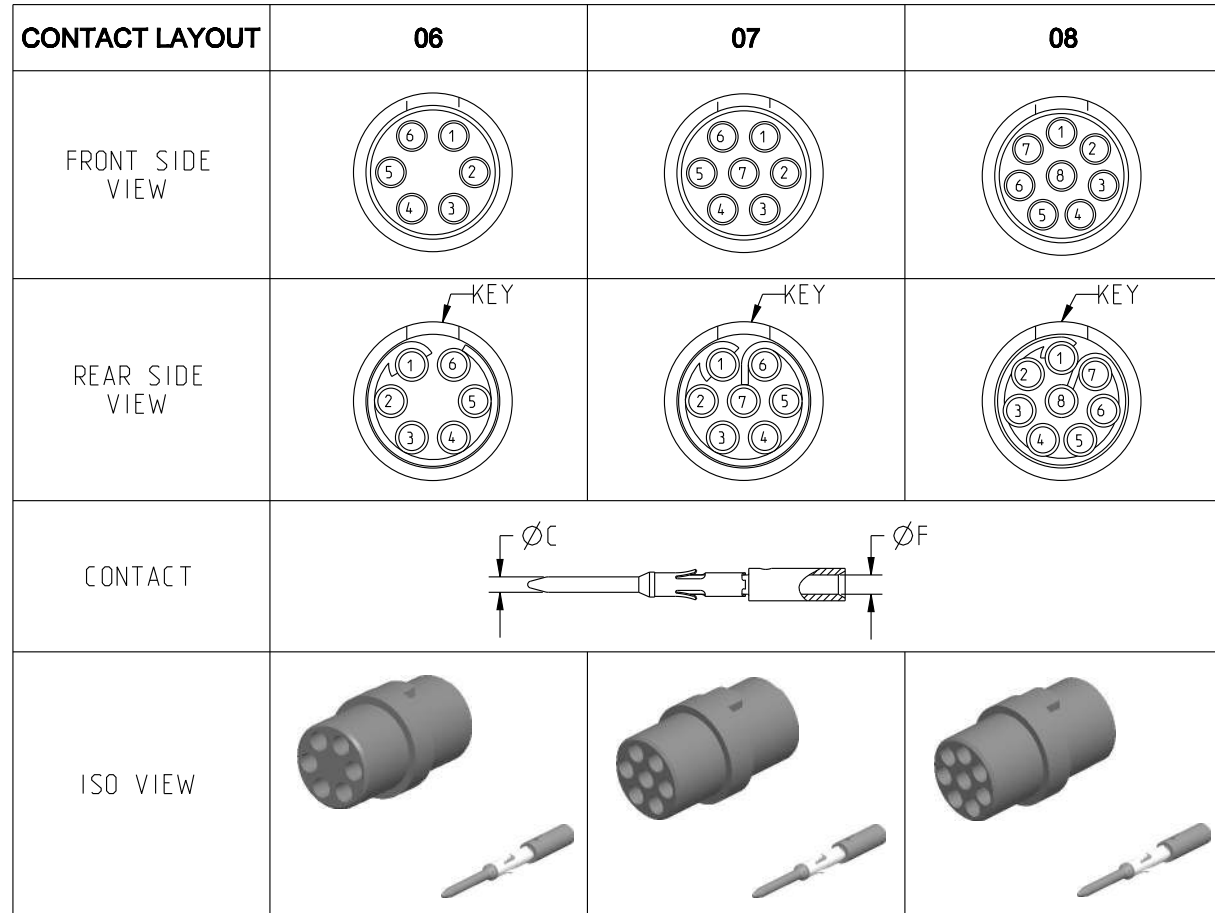

CONTACT	ØC	0.7	0.7	0.7
	ØF	0.85	0.85	0.85
	MAX. AWG	22	22	22
	MAX. CURRENT RATING (A)	7	7	7
INSULATOR	CONTACT RESISTANCE (mΩ)	5	5	5
	NUMBER OF CAVITY	6	7	8
	MAX. CURRENT RATING	7	7	5
	TEST VOLTAGE (Vrms)	1400	1400	1200
	WORKING VOLTAGE (Vdc/Vrms)	660/460	660/460	600/420

THIS DRAWING IS A CONTROLLED DOCUMENT FOR SOURIAU USA, INC. IT IS SUBJECT TO CHANGE WITHOUT NOTIFICATION. CONTACT THE DOCUMENT CONTROL CENTER FOR THE LATEST REVISION.

THE INFORMATION CONTAINED IN THIS DRAWING IS CONFIDENTIAL AND MAY NOT BE DISCLOSED WITHOUT WRITTEN CONSENT FROM SOURIAU USA, INC.

B

A

LINEAR MEASURE:		$\frac{mm}{INCH}$	mm (INCH)
THIRD ANGLE PROJECTION			
TOLERANCES UNLESS OTHERWISE SPECIFIED			
No. OF PLACES	mm [INCH]		
ONE PLACE	±3 [±.1]		
TWO PLACES	±0.5 [±.02]		
THREE PLACES	±0.25 [±.010]		
ANGLES ±1°			

ORIGIN	COUNTRY	JURISDICTION	CLASSIFICATION
X	FR	Not listed	N/A
	US	EAR	ECCN =EAR99

These commodities, technology or software are exported from the United States in accordance with the Export Administration Regulations. Diversion contrary to U.S. law is prohibited

DRAWING TITLE			
JBX, SIZE 1, MALE INSULATOR, CRIMP CONTACT			
CAT NO.			
JBX11NSMC			
CAGE NO: 09922		SIZE: B	
CUSTOMER		SOURIAU	
INTERPRET THIS DRAWING IN ACCORDANCE WITH ASME Y14.5M - 1994.		WWW.SOURIAU.COM	
APPROVAL	DRAWN: SKV	02-02-15	
	CHKD : EV	02-02-15	
	DSGN : EV	02-02-15	
	MFG : DH	02-02-15	
	QC : BB	02-02-15	
DRAWING SCALE: NA			
DRAWING NO.		REV	
JBX11NSMCC		B	
2 OF 2			