

# NOT RECOMMENDED FOR NEW DESIGNS



**DUAL SUPPLY  
OCTAL ECL-TO-TTL**

**Precision Edge®  
SY100HA643**

## FEATURES

- ECL/TTL version of popular ECLinPS™ E111
- 400ps within device skew
- 800ps part-to-part skew
- Latch
- Differential internal design
- V<sub>BB</sub> output
- Dual supply
- Reset/Enable
- Multiple TTL and ECL power/ground pins
- Fully compatible with MC100H643
- Higher performance than H643 versions
- Industrial temperature availability
- Available in 28-pin PLCC package



Precision Edge®

## DESCRIPTION

The SY100HA643 is an enhanced dual supply, low skew translating 1:8 clock driver. Devices in the Micrel H600 translators series utilize the 28-lead PLCC for optimal power pinning, signal flow through and electrical performance. The dual-supply HA643 is similar to the H641, which is a single-supply 1:9 version of the same function, with higher performance than the H643 versions.

The device features a 48mA TTL output stage, with AC performance specified into a 20pF load capacitance. A Latch is provided on-chip. When LEN is LOW (or left open, in which case it is pulled LOW by the internal pulldowns) the latch is transparent. A HIGH on the enable pin ( $\overline{EN}$ ) forces all outputs LOW.

The 100HA643 is compatible with 100K ECL logic levels.

## BLOCK DIAGRAM

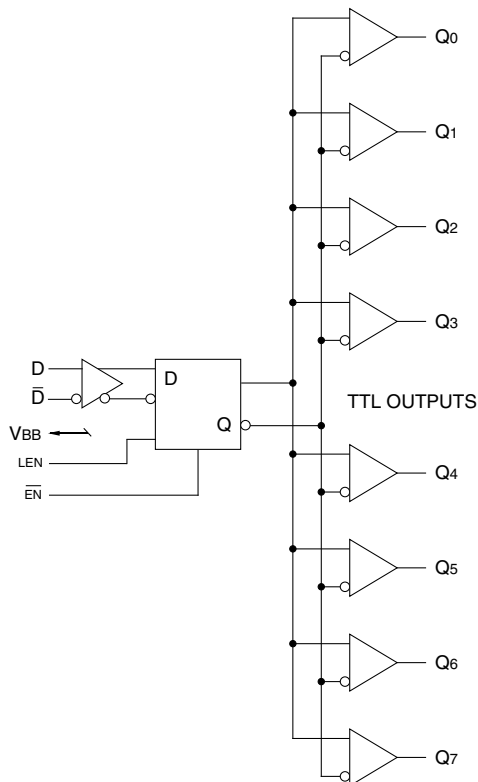

## PIN NAMES

Pin	Function
OGND	TTL Output Ground (0V)
OVTTL	Output V <sub>cc</sub> (+5.0V)
IGND	Internal TTL GND (0V)
IVT	Internal TTL V <sub>cc</sub> (+5.0V)
V <sub>EE</sub>	ECL V <sub>EE</sub> (-5.2/-4.5V)
V <sub>CCE</sub>	ECL Ground (0V)
D, $\overline{D}$	Signal Input (ECL)
V <sub>BB</sub>	V <sub>BB</sub> Reference Output
Q0 - Q7	Signal Outputs (TTL)
$\overline{EN}$	Enable Input (ECL)
LEN	Latch Enable Input (ECL)

Precision Edge is a registered trademark of Micrel, Inc.

**PACKAGE/ORDERING INFORMATION**

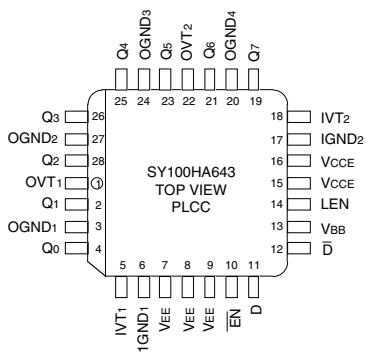

**28-Pin PLCC (J28-1)**

**Ordering Information<sup>(1)</sup>**

Part Number	Package Type	Operating Range	Package Marking	Lead Finish
SY100HA643JC	J28-1	Commercial	SY100HA643JC	Sn-Pb
SY100HA643JCTR <sup>(2)</sup>	J28-1	Commercial	SY100HA643JC	Sn-Pb
SY100HA643JI	J28-1	Industrial	SY100HA643JI	Sn-Pb
SY100HA643JITR <sup>(2)</sup>	J28-1	Industrial	SY100HA643JI	Sn-Pb
SY100HA643JY <sup>(3)</sup>	J28-1	Industrial	SY100HA643JY with Pb-Free bar-line indicator	Matte-Sn
SY100HA643JYTR <sup>(2, 3)</sup>	J28-1	Industrial	SY100HA643JY with Pb-Free bar-line indicator	Matte-Sn

**Notes:**

1. Contact factory for die availability. Dice are guaranteed at T<sub>A</sub> = 25°C, DC Electricals only.
2. Tape and Reel.
3. Pb-Free package is recommended for new designs.

**TRUTH TABLE**

D	LEN	$\overline{EN}$	Q
L	L	L	L
H	L	L	H
X	X	H	L

**DC CHARACTERISTICS**

IVT = OVT = 5.0V ±5%; VEE = -4.2V to -5.5V; VCC = GND

Symbol	Parameter	TA = -40°C		TA = 0°C		TA = +25°C		TA = +85°C		Unit	Condition
		Min.	Max.	Min.	Max.	Min.	Max.	Min.	Max.		
IEE	Power Supply	—	58	—	58	—	58	—	58	mA	VEE Pins Total all OVT and IVT pins
ICCL		—	83	—	83	—	83	—	83	mA	
ICCH		—	73	—	73	—	73	—	73	mA	
VOH	TTL Output HIGH Voltage	2.5 2.0	— —	2.5 2.0	— —	2.5 2.0	— —	2.5 2.0	— —	V	IOH = -3.0mA IOH = -15mA
VOL	TTL Output LOW Voltage	—	0.5	—	0.5	—	0.5	—	0.5	V	IOL = 48mA
Ios	TTL Output Short Circuit Current	-80	-200	-80	-200	-80	-200	-80	-200	mA	VOU = 0V
IiH	ECL Input HIGH Current	—	225	—	225	—	175	—	175	A	
IiL	ECL Input LOW Current	0.5	—	0.5	—	0.5	—	0.5	—	A	
Vih	ECL Input HIGH Voltage	—	—	-1165	-880	-1165	-880	-1165	-880	mV	
Vil	ECL Input LOW Voltage	—	—	-1810	-1475	-1810	-1475	-1810	-1475	mV	
VBB	ECL Output Reference Voltage	-1380	-1260	-1380	-1260	-1380	-1260	-1380	-1260	mV	

**AC CHARACTERISTICS**

IVT = OVT = 5.0V ±5%; VEE = -4.2V to -5.5V ; VCC = GND

Symbol	Parameter	TA = -40°C		TA = 0°C		TA = +25°C		TA = +85°C		Unit	Condition
		Min.	Max.	Min.	Max.	Min.	Max.	Min.	Max.		
t <sub>IH</sub>	Propagation Delay to Output D LEN EN	2.3	3.1	2.3	3.1	2.3	3.1	2.3	3.1	ns	CL = 20pF
t <sub>skew</sub>	Within-Device Skew <sup>(1)</sup>	—	0.4	—	0.4	—	0.4	—	0.4	ns	
t <sub>PW</sub>	Pulse Width Out <sup>(2)</sup> HIGH or LOW @ FOUT = 100MHz	4.5	5.5	4.5	5.5	4.5	5.5	4.5	5.5	ns	CL = 20pF
t <sub>S</sub>	Setup Time D	0.75	—	0.75	—	0.75	—	0.75	—	ns	
t <sub>H</sub>	Hold Time D	0.75	—	0.75	—	0.75	—	0.75	—	ns	
t <sub>RR</sub>	Recovery Time LEN EN	1.25 1.25	— —	1.25 1.25	— —	1.25 1.25	— —	1.25 1.25	— —	ns ns	
t <sub>PW</sub>	Minimum Pulse Width LEN EN	1.5 1.5	— —	1.5 1.5	— —	1.5 1.5	— —	1.5 1.5	— —	ns ns	
t <sub>r</sub> t <sub>f</sub>	Rise / Fall times 0.8V — 2.0V	—	1.5	—	1.5	—	1.5	—	1.5	ns	CL = 20pF
f <sub>MAX</sub>	Max. Input Frequency <sup>(3,4)</sup>	160	—	160	—	160	—	160	—	MHz	CL = 20pF

**Notes:**

1. Within-Device skew defined as identical transitions on similar paths through a device.
2. Pulse width is defined relative to 1.5V measurement points on the output waveform.
3. Frequency at which output levels will meet a 0.8V to 2.0V minimum swing.
4. The f<sub>MAX</sub> value is specified as the minimum guaranteed maximum frequency. Actual operational maximum frequency may be greater.

**28-PIN PLCC (J28-1)**

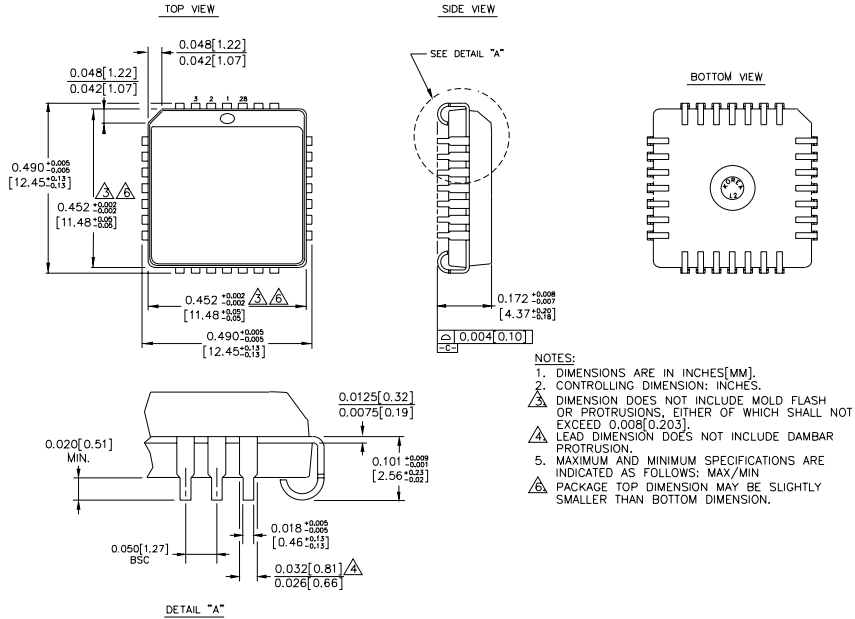

Rev. 03

**MICREL, INC. 2180 FORTUNE DRIVE SAN JOSE, CA 95131 USA**

TEL + 1 (408) 944-0800 FAX + 1 (408) 474-1000 WEB <http://www.micrel.com>

The information furnished by Micrel in this data sheet is believed to be accurate and reliable. However, no responsibility is assumed by Micrel for its use. Micrel reserves the right to change circuitry and specifications at any time without notification to the customer.

Micrel Products are not designed or authorized for use as components in life support appliances, devices or systems where malfunction of a product can reasonably be expected to result in personal injury. Life support devices or systems are devices or systems that (a) are intended for surgical implant into the body or (b) support or sustain life, and whose failure to perform can be reasonably expected to result in a significant injury to the user. A Purchaser's use or sale of Micrel Products for use in life support appliances, devices or systems is at Purchaser's own risk and Purchaser agrees to fully indemnify Micrel for any damages resulting from such use or sale.

© 2006 Micrel, Incorporated.