

MULTI-BEAM LS4EL/RL Light Screen Systems

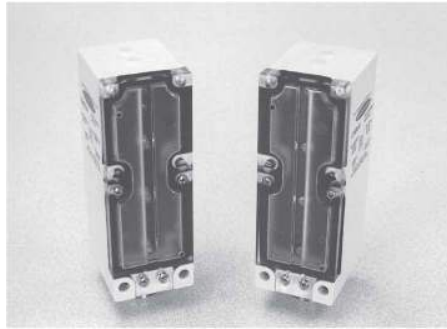

Datasheet



WARNING:

- **Do not use this device for personnel protection**
- Using this device for personnel protection could result in serious injury or death.
- This device does not include the self-checking redundant circuitry necessary to allow its use in personnel safety applications. A device failure or malfunction can cause either an energized (on) or de-energized (off) output condition.

Models

One receiver and one emitter per system. Use either emitter with either receiver.

Model	Self-Contained Unit	Fitting
LS4EL	Emitter	2 m (6.5) cable
LS4RL	Receiver	2 m (6.5) cable
LS4ELQ	Emitter	4-pin mini-style quick disconnect
LS4RLQ	Receiver	4-pin mini-style quick disconnect

Overview

LS4EL/RL Light Screen Systems offer a simple, economical, but highly reliable means of sensing objects moving at high speed through an area (or window.) Each system consists of two self-contained units: an emitter and a receiver. Emitters contain four infrared light sources aligned in a row and strobed (turned ON one at a time) in a specific sequence and at a high frequency. Receivers contain a matching array of phototransistors. The height of the array is 90 mm (3.5 in). The LS4RL receiver may be placed 45.7 cm to 228.6 cm (18 in to 90 in) opposed from the LS4EL emitter. This produces a curtain of light 127 mm to 152 mm (5 in to 6 in) high and as wide as the separation distance between the emitter and receiver.

The smallest object that can be detected depends upon the location of the object within the curtain. Midway between emitter and receiver an object 25 mm (1 in) or larger in a cross section can be detected anywhere within a 125 mm (5 in) high window. Near the emitter or receiver, an object of 38 mm (1.5 in) or larger in cross section can be detected anywhere within a 152 mm (6 in) high window.

The light from the emitter is modulated to minimize sensitivity of the system to ambient light. An indicator LED on the emitter lights whenever power is applied. The receiver has an alignment LED which lights whenever the beam is broken. Models are available with either attached cable or integral quick disconnect fitting. The receiver output interfaces directly with dc loads or circuits up to 30 V dc, and offers both NPN and PNP output transistors. Outputs are energized continuously while the beam is broken. A 5 millisecond pulse stretcher (OFF delay) is included to improve interfacing reliability.

Wiring Diagram

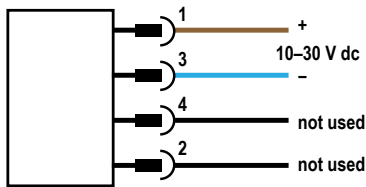

Figure 1. LS4E Emitter. Cabled wiring diagrams are functionally identical.

Key
 1 = Brown
 2 = White
 3 = Blue
 4 = Black

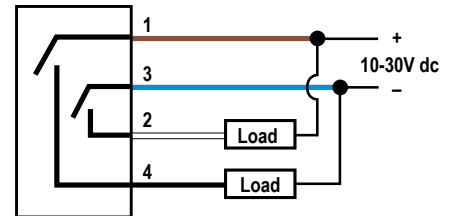

Figure 2. LS4R Receiver. Quick disconnect wiring diagrams are functionally identical.



Installation and Alignment

The reliable performance of Light Screen Systems requires careful alignment and secure mounting. The model SMBLS 2-part, 3-axis mounting bracket is highly recommended. Solid mounting is important. Mounting locations should be as free from vibration as possible. If vibration is unavoidable, allow the emitter and receiver to vibrate together; no high-amplitude differential vibration is allowed.

Mount the emitter and receiver facing each other at their operation locations. Their faces (front panels) should be exactly parallel and opposite each other. The line of transmitter LEDs should be exactly parallel with and opposite to the line of receiver phototransistors. This constitutes optimal mechanical alignment.

Optimum mechanical alignment does not always result in optimum optical alignment. When optical alignment is optimum, the receiver status indicator (on the front of the receiver) will be OFF and remain OFF with a moderate level of vibration at either the emitter or receiver.

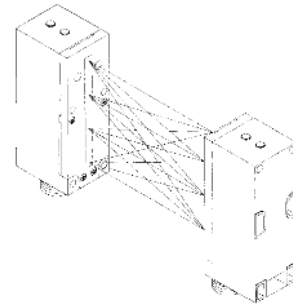

Figure 3. Alignment of the emitter and receiver

Beginning with optimum mechanical alignment, adjust for optimum optical alignment as described in steps 1 through 6. This procedure assumes use of the SMBLS mounting bracket.

1. Loosen the two bolts holding the two parts of the bracket together just enough to allow the upper (carriage) bracket along with the emitter to be rotated about the emitter's vertical axis.
2. Slightly loosen the mounting bolts in the curved slots of the base bracket, which will allow the SMBLS bracket to be tipped side-to-side.
3. With power applied to both units, tip the entire SMBLS bracket slightly from side-to-side.
 - a. Find the extremes of movement between which the receiver's red indicator LED remains OFF.
 - b. Secure the base bracket at the point midway between the extremes.
4. Rotate the carriage bracket (to which the emitter is attached) slightly in both directions about the emitter's vertical axis.
 - a. Find the extremes of bracket rotation between which the receiver's red indicator LED remains OFF.
 - b. Secure the emitter midway between the extremes by tightening the two bolts that lock the two parts of the SMBLS bracket together.
5. Loosen the two mounting bolts that hold the emitter to the carriage bracket.
 - a. Slide the emitter up and down vertically in the bracket, noting the extremes between which the receiver's red LED indicator remains OFF.
 - b. Tighten the bolts to secure the emitter midway between the extremes.



Note: If the initial mechanical alignment was inadequate, it may be necessary to repeatedly alternate tipping, rotating, and sliding movements before optimal optical alignment is attained.

6. Perform step 3 again, this time using the receiver unit and its bracket.
7. Check for proper alignment by breaking one or more of the beams. The receiver indicator LED and outputs should come ON when one or more beams are broken.
8. Tighten all mounting hardware securely in position.

Specifications

Supply Voltage

LS4EL(Q): 10 V dc to 30 V dc at 35 mA maximum, exclusive of load
 LS4RL(Q): 10 V dc to 30 V dc at 25 mA maximum, exclusive of load

Output Configuration

One NPN and one PNP open collector transistor

Output Rating

125 mA continuous, either output

Output Protection Circuitry

Protected against reverse polarity and output short-circuit

Range

45.7 cm to 228.6 cm (18 in to 90 in)

Resolution

25 mm to 38 mm (1 in to 1.5 in), depending upon the location of the object within the curtain

Response Time

1 millisecond; successive parts must have at least 10 milliseconds of separation

Construction

Reinforced PBT polyester housing; acrylic lens; lens are fully gasketed; NEMA 1, 2, 3, 12, and 13; stainless steel hardware

Cabling

2 m (6.5 ft) attached cable or 4-pin mini-style quick disconnect fitting

Operating Temperature

0 °C to +50 °C (+32 °F to +122 °F)

Dimensions

All measurements are listed in inches (mm), unless noted otherwise.

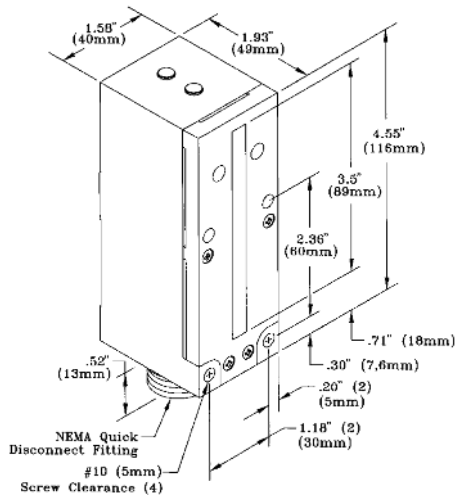

Accessories

Bracket

- Model SMBLS is an accessory two-part bracket assembly that allows adjustment in three directions. It consists of two 11-gauge zinc-plated steel right-angle brackets that fasten together so that they rotate relative to each other.
- The light screen sensor attaches to the upper bracket. Slots are provided for vertical adjustment.
- The SMBLS must be ordered separately from the light screen sensors.

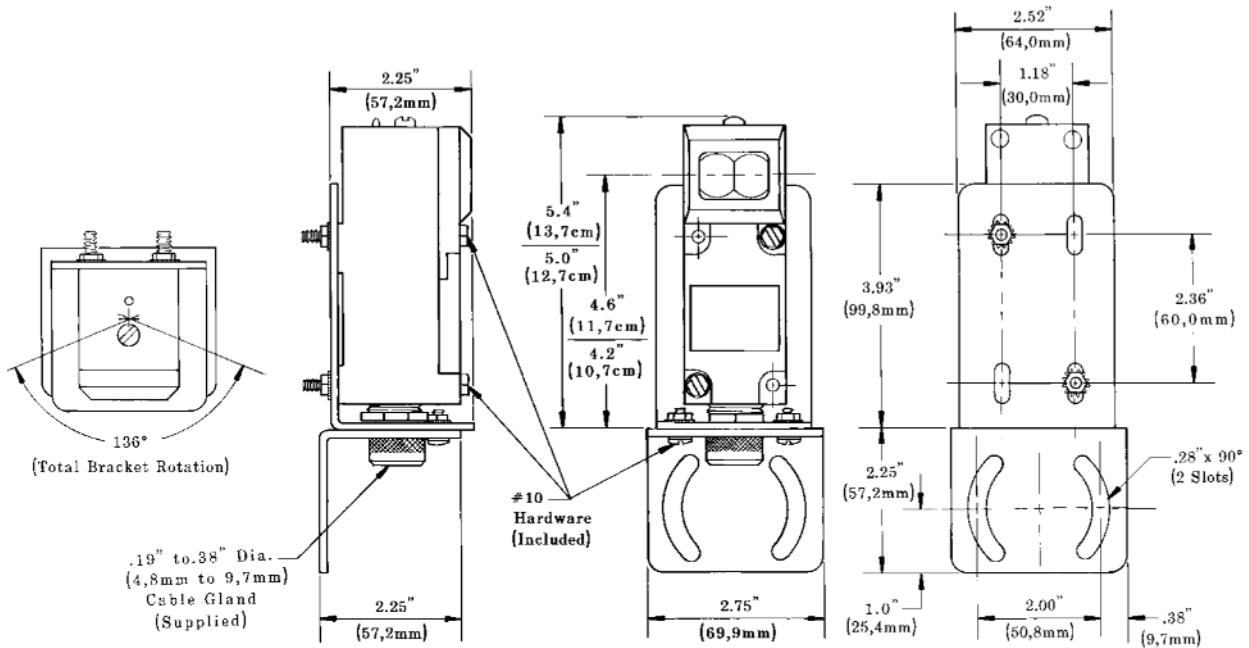
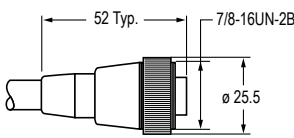
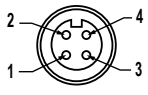

Figure 4. SMBLS Bracket Dimensions

Cordsets

4-Pin Mini-Style Cordsets—Single Ended				
Model	Length	Style	Dimensions	Pinout (Female)
MBCC-406	1.83 m (6 ft)	Straight		
MBCC-412	3.66 m (12 ft)			
MBCC-430	9.14 m (30 ft)			

Banner Engineering Corp Limited Warranty

Banner Engineering Corp. warrants its products to be free from defects in material and workmanship for one year following the date of shipment. Banner Engineering Corp. will repair or replace, free of charge, any product of its manufacture which, at the time it is returned to the factory, is found to have been defective during the warranty period. This warranty does not cover damage or liability for misuse, abuse, or the improper application or installation of the Banner product.

THIS LIMITED WARRANTY IS EXCLUSIVE AND IN LIEU OF ALL OTHER WARRANTIES WHETHER EXPRESS OR IMPLIED (INCLUDING, WITHOUT LIMITATION, ANY WARRANTY OF MERCHANTABILITY OR FITNESS FOR A PARTICULAR PURPOSE), AND WHETHER ARISING UNDER COURSE OF PERFORMANCE, COURSE OF DEALING OR TRADE USAGE.

This Warranty is exclusive and limited to repair or, at the discretion of Banner Engineering Corp., replacement. **IN NO EVENT SHALL BANNER ENGINEERING CORP. BE LIABLE TO BUYER OR ANY OTHER PERSON OR ENTITY FOR ANY EXTRA COSTS, EXPENSES, LOSSES, LOSS OF PROFITS, OR ANY INCIDENTAL, CONSEQUENTIAL OR SPECIAL DAMAGES RESULTING FROM ANY PRODUCT DEFECT OR FROM THE USE OR INABILITY TO USE THE PRODUCT, WHETHER ARISING IN CONTRACT OR WARRANTY, STATUTE, TORT, STRICT LIABILITY, NEGLIGENCE, OR OTHERWISE.**

Banner Engineering Corp. reserves the right to change, modify or improve the design of the product without assuming any obligations or liabilities relating to any product previously manufactured by Banner Engineering Corp. Any misuse, abuse, or improper application or installation of this product or use of the product for personal protection applications when the product is identified as not intended for such purposes will void the product warranty. Any modifications to this product without prior express approval by Banner Engineering Corp will void the product warranties. All specifications published in this document are subject to change; Banner reserves the right to modify product specifications or update documentation at any time. Specifications and product information in English supersede that which is provided in any other language. For the most recent version of any documentation, refer to: www.bannerengineering.com.

For patent information, see www.bannerengineering.com/patents.