

The mini-analog series is a group of ICs that incorporate a general purpose analog circuit in a small package. S-89130/89140 Series is a CMOS type operational amplifier that has a phase compensation circuit, and operates at a low voltage with low current consumption. S-89130/89140 Series can operate within a wide temperature range of  $-40^{\circ}\text{C}$  to  $+125^{\circ}\text{C}$ .

This product is a dual operational amplifier (two circuits).

## ■ Features

- Lower operating voltage :  $V_{\text{DD}} = 2.7\text{ V to }5.5\text{ V}$
- Low current consumption (per circuit) :  $I_{\text{DD}} = 1.00\text{ mA typ. (S-89130 Series, }V_{\text{DD}} = 5.0\text{ V)}$   
 $I_{\text{DD}} = 0.27\text{ mA typ. (S-89140 Series, }V_{\text{DD}} = 5.0\text{ V)}$
- Low input offset voltage :  $V_{\text{IO}} = 6.0\text{ mV max. (S-89130 Series)}$   
 $V_{\text{IO}} = 7.0\text{ mV max. (S-89140 Series)}$
- Operational temperature range :  $-40^{\circ}\text{C to }+125^{\circ}\text{C}$
- No external capacitors required for internal phase compensation
- Lead-free (Sn 100%), halogen-free <sup>\*1</sup>

\*1. Refer to “■ Product Name Structure” for details.

## ■ Applications

- Current sensing
- Signal amplification
- Buffer
- Active filter
- Electronics devices

## ■ Packages

- SNT-8A
- TMSOP-8

**Caution** This product is intended to use in general electronic devices such as consumer electronics, office equipment, and communications devices. Before using the product in medical equipment or automobile equipment including car audio, keyless entry and engine control unit, contact to ABLIC Inc. is indispensable.

■ Block Diagram

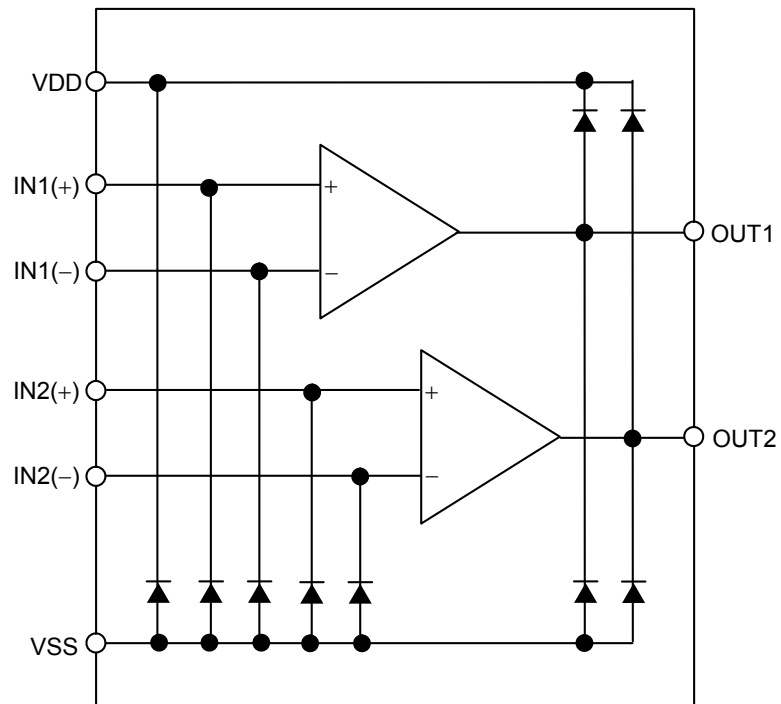
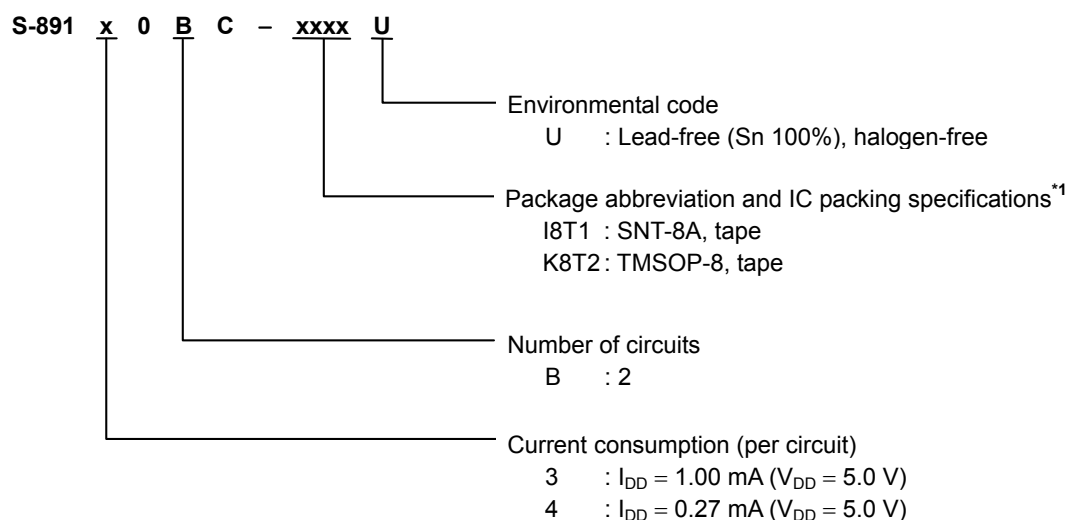

Figure 1

## ■ Product Name Structure

Users can select the product type for the S-89130/89140 Series. Refer to “1. Product name” regarding the contents of product name, “2. Packages” regarding the package drawings and “3. Product name list” regarding the product type.

### 1. Product name



\*1. Refer to the tape specifications

### 2. Packages

Package Name	Drawing Code			
	Package	Tape	Reel	Land
SNT-8A	PH008-A-P-SD	PH008-A-C-SD	PH008-A-R-SD	PH008-A-L-SD
TMSOP-8	FM008-A-P-SD	FM008-A-C-SD	FM008-A-R-SD	–

### 3. Product name list

Table 1

Product name	Current consumption (per circuit)*1	Gain-bandwidth*1	Package
S-89130BC-I8T1U	1.00 mA	3.0 MHz	SNT-8A
S-89130BC-K8T2U	1.00 mA	3.0 MHz	TMSOP-8
S-89140BC-I8T1U	0.27 mA	1.0 MHz	SNT-8A
S-89140BC-K8T2U	0.27 mA	1.0 MHz	TMSOP-8

\*1. The value when  $V_{DD} = 5.0 \text{ V}$

■ Pin Configurations

1. SNT-8A

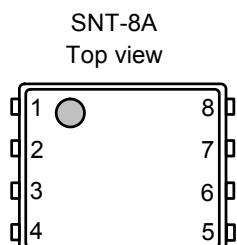

Figure 2

Table 2

Pin No.	Symbol	Description
1	OUT1	Output pin 1
2	IN1(-)	Inverted input pin 1
3	IN1(+)	Non-inverted input pin 1
4	VSS	GND pin
5	IN2(+)	Non-inverted input pin 2
6	IN2(-)	Inverted input pin 2
7	OUT2	Output pin 2
8	VDD	Positive power supply pin

2. TMSOP-8

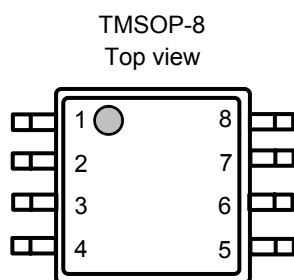

Figure 3

Table 3

Pin No.	Symbol	Description
1	OUT1	Output pin 1
2	IN1(-)	Inverted input pin 1
3	IN1(+)	Non-inverted input pin 1
4	VSS	GND pin
5	IN2(+)	Non-inverted input pin 2
6	IN2(-)	Inverted input pin 2
7	OUT2	Output pin 2
8	VDD	Positive power supply pin

■ **Absolute Maximum Ratings**

Table 4

(Ta = +25°C unless otherwise specified)

Parameter	Symbol	Absolute Maximum Rating	Unit
Power supply voltage	V <sub>DD</sub>	V <sub>SS</sub> - 0.3 to V <sub>SS</sub> + 7.0	V
Input voltage	V <sub>IN(+)</sub> , V <sub>IN(-)</sub>	V <sub>SS</sub> - 0.3 to V <sub>SS</sub> + 7.0	V
Output voltage	V <sub>OUT</sub>	V <sub>SS</sub> - 0.3 to V <sub>DD</sub> + 0.3	V
Differential input voltage	V <sub>IND</sub>	±7.0	V
Output pin current	I <sub>SOURCE</sub>	20.0	mA
	I <sub>SINK</sub>	20.0	mA
Power dissipation	P <sub>D</sub>	550 <sup>*1</sup>	mW
		800 <sup>*1</sup>	mW
Operating ambient temperature	T <sub>opr</sub>	-40 to +125	°C
Junction temperature	T <sub>j</sub>	-55 to +150	°C
Storage temperature	T <sub>stg</sub>	-55 to +150	°C

\*1. When mounted on board

[Mounted board]

(1) Board size : 114.3 mm × 76.2 mm × t1.6 mm

(2) Board name : JEDEC STANDARD51-7

**Caution** The absolute maximum ratings are rated values exceeding which the product could suffer physical damage. These values must therefore not be exceeded under any conditions.

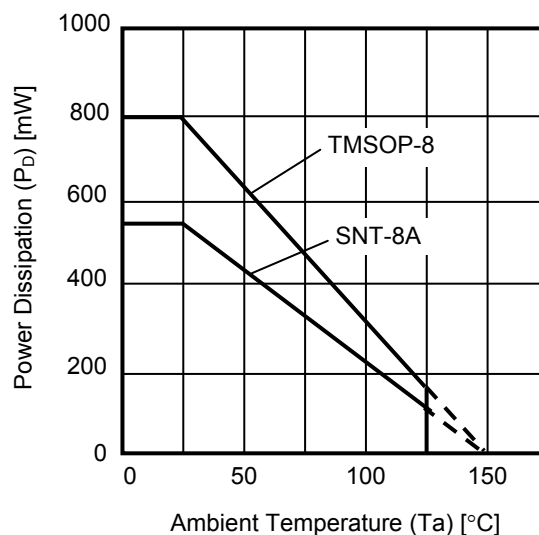

Figure 4 Power Dissipation of Package (When Mounted on Board)

■ **Electrical Characteristics**

**1. S-89130 Series**

**Table 5**

(Ta = +25°C unless otherwise specified)

Parameter	Symbol	Conditions	Min.	Typ.	Max.	Unit	Test Circuit
Range of operating power supply voltage	V <sub>DD</sub>	–	2.7	–	5.5	V	–

**1.1 V<sub>DD</sub> = 5.0 V**

**Table 6**

(Ta = +25°C unless otherwise specified)

**DC Electrical Characteristics (V<sub>DD</sub> = 5.0 V)**

Parameter	Symbol	Conditions	Min.	Typ.	Max.	Unit	Test Circuit
Current consumption (per circuit)	I <sub>DD</sub>	V <sub>CMR</sub> = V <sub>OUT</sub> = V <sub>DD</sub> / 2	–	1.00	1.25	mA	5
Input offset voltage	V <sub>IO</sub>	V <sub>CMR</sub> = V <sub>DD</sub> / 2	–6.0	±3.0	+6.0	mV	1
Input offset voltage drift	$\frac{\Delta V_{IO}}{\Delta T_a}$	V <sub>CMR</sub> = V <sub>DD</sub> / 2	–	±3	–	μV/°C	1
Input offset current	I <sub>IO</sub>	–	–	1	–	pA	–
Input bias current	I <sub>BIAS</sub>	–	–	1	–	pA	–
Common-mode input voltage range	V <sub>CMR</sub>	–	–0.1	–	3.8	V	2
Voltage gain (open loop)	A <sub>VOL</sub>	V <sub>OUT</sub> = V <sub>SS</sub> + 0.5 V to V <sub>DD</sub> – 0.5 V V <sub>CMR</sub> = V <sub>DD</sub> / 2, R <sub>L</sub> = 1.0 MΩ	88	110	–	dB	8
Maximum output swing voltage	V <sub>OH</sub>	R <sub>L</sub> = 1.0 MΩ	4.9	–	–	V	3
	V <sub>OL</sub>	R <sub>L</sub> = 1.0 MΩ	–	–	0.1	V	4
Common-mode input signal rejection ratio	CMRR	V <sub>CMR</sub> = V <sub>SS</sub> – 0.1 V to V <sub>DD</sub> – 1.2 V	70	85	–	dB	2
Power supply voltage rejection ratio	PSRR	V <sub>DD</sub> = 2.7 V to 5.5 V	70	90	–	dB	1
Source current	I <sub>SOURCE</sub>	V <sub>OUT</sub> = V <sub>DD</sub> – 0.12 V	5.0	–	–	mA	6
Sink current	I <sub>SINK</sub>	V <sub>OUT</sub> = 0.12 V	5.0	–	–	mA	7

**Table 7**

(Ta = +25°C unless otherwise specified)

**AC Electrical Characteristics (V<sub>DD</sub> = 5.0 V)**

Parameter	Symbol	Conditions	Min.	Typ.	Max.	Unit
Slew rate	SR	R <sub>L</sub> = 1.0 MΩ, C <sub>L</sub> = 15 pF (Refer to <b>Figure 13</b> )	–	2.0	–	V/μs
Gain-bandwidth product	GBP	C <sub>L</sub> = 0 pF	–	3.0	–	MHz

**MINI ANALOG SERIES CMOS OPERATIONAL AMPLIFIER**  
**S-89130/89140 Series**

Rev.1.0\_02

**1.2 V<sub>DD</sub> = 2.7 V**

**Table 8**

**DC Electrical Characteristics (V<sub>DD</sub> = 2.7 V)**

(T<sub>a</sub> = +25°C unless otherwise specified)

Parameter	Symbol	Conditions	Min.	Typ.	Max.	Unit	Test Circuit
Current consumption (per circuit)	I <sub>DD</sub>	V <sub>CMR</sub> = V <sub>OUT</sub> = V <sub>DD</sub> / 2	–	0.90	1.20	mA	5
Input offset voltage	V <sub>IO</sub>	V <sub>CMR</sub> = V <sub>DD</sub> / 2	–6.0	±3.0	+6.0	mV	1
Input offset voltage drift	$\frac{\Delta V_{IO}}{\Delta T_a}$	V <sub>CMR</sub> = V <sub>DD</sub> / 2	–	±3	–	μV/°C	1
Input offset current	I <sub>IO</sub>	–	–	1	–	pA	–
Input bias current	I <sub>BIAS</sub>	–	–	1	–	pA	–
Common-mode input voltage range	V <sub>CMR</sub>	–	–0.1	–	1.5	V	2
Voltage gain (open loop)	A <sub>VOL</sub>	V <sub>OUT</sub> = V <sub>SS</sub> + 0.5 V to V <sub>DD</sub> – 0.5 V V <sub>CMR</sub> = V <sub>DD</sub> / 2, R <sub>L</sub> = 1.0 MΩ	80	110	–	dB	8
Maximum output swing voltage	V <sub>OH</sub>	R <sub>L</sub> = 1.0 MΩ	2.6	–	–	V	3
	V <sub>OL</sub>	R <sub>L</sub> = 1.0 MΩ	–	–	0.1	V	4
Common-mode input signal rejection ratio	CMRR	V <sub>CMR</sub> = V <sub>SS</sub> – 0.1 V to V <sub>DD</sub> – 1.2 V	65	85	–	dB	2
Power supply voltage rejection ratio	PSRR	V <sub>DD</sub> = 2.7 V to 5.5 V	70	90	–	dB	1
Source current	I <sub>SOURCE</sub>	V <sub>OUT</sub> = V <sub>DD</sub> – 0.12 V	5.0	–	–	mA	6
Sink current	I <sub>SINK</sub>	V <sub>OUT</sub> = 0.12 V	5.0	–	–	mA	7

**Table 9**

**AC Electrical Characteristics (V<sub>DD</sub> = 2.7 V)**

(T<sub>a</sub> = +25°C unless otherwise specified)

Parameter	Symbol	Conditions	Min.	Typ.	Max.	Unit
Slew rate	SR	R <sub>L</sub> = 1.0 MΩ, C <sub>L</sub> = 15 pF (Refer to <b>Figure 13</b> )	–	2.0	–	V/μs
Gain-bandwidth product	GBP	C <sub>L</sub> = 0 pF	–	3.0	–	MHz

**2. S-89140 Series**

**Table 10**

(Ta = +25°C unless otherwise specified)

Parameter	Symbol	Conditions	Min.	Typ.	Max.	Unit	Test Circuit
Range of operating power supply voltage	V <sub>DD</sub>	–	2.7	–	5.5	V	–

**2.1 V<sub>DD</sub> = 5.0 V**

**Table 11**

**DC Electrical Characteristics (V<sub>DD</sub> = 5.0 V)**

(Ta = +25°C unless otherwise specified)

Parameter	Symbol	Conditions	Min.	Typ.	Max.	Unit	Test Circuit
Current consumption (per circuit)	I <sub>DD</sub>	V <sub>CMR</sub> = V <sub>OUT</sub> = V <sub>DD</sub> / 2	–	0.27	0.35	mA	5
Input offset voltage	V <sub>IO</sub>	V <sub>CMR</sub> = V <sub>DD</sub> / 2	–7.0	±3.0	+7.0	mV	1
Input offset voltage drift	$\frac{\Delta V_{IO}}{\Delta T_a}$	V <sub>CMR</sub> = V <sub>DD</sub> / 2	–	±3	–	μV/°C	1
Input offset current	I <sub>IO</sub>	–	–	1	–	pA	–
Input bias current	I <sub>BIAS</sub>	–	–	1	–	pA	–
Common-mode input voltage range	V <sub>CMR</sub>	–	–0.1	–	3.8	V	2
Voltage gain (open loop)	A <sub>VOL</sub>	V <sub>OUT</sub> = V <sub>SS</sub> + 0.5 V to V <sub>DD</sub> – 0.5 V V <sub>CMR</sub> = V <sub>DD</sub> / 2, R <sub>L</sub> = 1.0 MΩ	88	110	–	dB	8
Maximum output swing voltage	V <sub>OH</sub>	R <sub>L</sub> = 1.0 MΩ	4.9	–	–	V	3
	V <sub>OL</sub>	R <sub>L</sub> = 1.0 MΩ	–	–	0.1	V	4
Common-mode input signal rejection ratio	CMRR	V <sub>CMR</sub> = V <sub>SS</sub> – 0.1 V to V <sub>DD</sub> – 1.2 V	70	85	–	dB	2
Power supply voltage rejection ratio	PSRR	V <sub>DD</sub> = 2.7 V to 5.5 V	70	90	–	dB	1
Source current	I <sub>SOURCE</sub>	V <sub>OUT</sub> = V <sub>DD</sub> – 0.12 V	5.0	–	–	mA	6
Sink current	I <sub>SINK</sub>	V <sub>OUT</sub> = 0.12 V	5.0	–	–	mA	7

**Table 12**

**AC Electrical Characteristics (V<sub>DD</sub> = 5.0 V)**

(Ta = +25°C unless otherwise specified)

Parameter	Symbol	Conditions	Min.	Typ.	Max.	Unit
Slew rate	SR	R <sub>L</sub> = 1.0 MΩ, C <sub>L</sub> = 15 pF (Refer to <b>Figure 13</b> )	–	0.5	–	V/μs
Gain-bandwidth product	GBP	C <sub>L</sub> = 0 pF	–	1.0	–	MHz



**MINI ANALOG SERIES CMOS OPERATIONAL AMPLIFIER**  
**S-89130/89140 Series**

Rev.1.0\_02

**2.2 V<sub>DD</sub> = 2.7 V**

**Table 13**

**DC Electrical Characteristics (V<sub>DD</sub> = 2.7 V)**

(T<sub>a</sub> = +25°C unless otherwise specified)

Parameter	Symbol	Conditions	Min.	Typ.	Max.	Unit	Test Circuit
Current consumption (per circuit)	I <sub>DD</sub>	V <sub>CMR</sub> = V <sub>OUT</sub> = V <sub>DD</sub> / 2	–	0.25	0.33	mA	5
Input offset voltage	V <sub>IO</sub>	V <sub>CMR</sub> = V <sub>DD</sub> / 2	–7.0	±3.0	+7.0	mV	1
Input offset voltage drift	$\frac{\Delta V_{IO}}{\Delta T_a}$	V <sub>CMR</sub> = V <sub>DD</sub> / 2	–	±3	–	μV/°C	1
Input offset current	I <sub>IO</sub>	–	–	1	–	pA	–
Input bias current	I <sub>BIAS</sub>	–	–	1	–	pA	–
Common-mode input voltage range	V <sub>CMR</sub>	–	–0.1	–	1.5	V	2
Voltage gain (open loop)	A <sub>VOL</sub>	V <sub>OUT</sub> = V <sub>SS</sub> + 0.5 V to V <sub>DD</sub> – 0.5 V V <sub>CMR</sub> = V <sub>DD</sub> / 2, R <sub>L</sub> = 1.0 MΩ	80	110	–	dB	8
Maximum output swing voltage	V <sub>OH</sub>	R <sub>L</sub> = 1.0 MΩ	2.6	–	–	V	3
	V <sub>OL</sub>	R <sub>L</sub> = 1.0 MΩ	–	–	0.1	V	4
Common-mode input signal rejection ratio	CMRR	V <sub>CMR</sub> = V <sub>SS</sub> – 0.1 V to V <sub>DD</sub> – 1.2 V	65	85	–	dB	2
Power supply voltage rejection ratio	PSRR	V <sub>DD</sub> = 2.7 V to 5.5 V	70	90	–	dB	1
Source current	I <sub>SOURCE</sub>	V <sub>OUT</sub> = V <sub>DD</sub> – 0.12 V	5.0	–	–	mA	6
Sink current	I <sub>SINK</sub>	V <sub>OUT</sub> = 0.12 V	5.0	–	–	mA	7

**Table 14**

**AC Electrical Characteristics (V<sub>DD</sub> = 2.7 V)**

(T<sub>a</sub> = +25°C unless otherwise specified)

Parameter	Symbol	Conditions	Min.	Typ.	Max.	Unit
Slew rate	SR	R <sub>L</sub> = 1.0 MΩ, C <sub>L</sub> = 15 pF (Refer to <b>Figure 13</b> )	–	0.5	–	V/μs
Gain-bandwidth product	GBP	C <sub>L</sub> = 0 pF	–	1.0	–	MHz

■ Test Circuit (Per Circuit)

1. Power supply voltage rejection ratio, input offset voltage

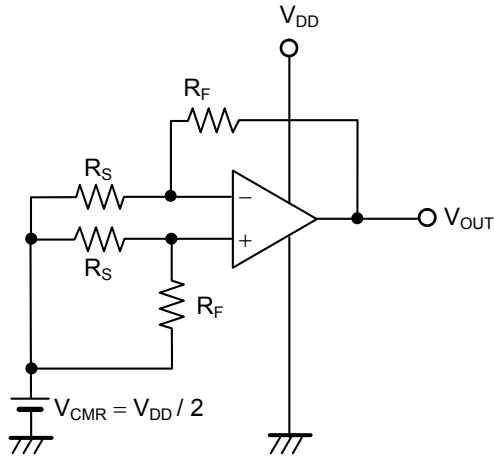

Figure 5

• Power supply voltage rejection ratio (PSRR)

The power supply voltage rejection ratio (PSRR) can be calculated by the following expression, with  $V_{OUT}$  measured at each  $V_{DD}$ .

Test conditions:

$V_{DD} = 2.7\text{ V}$ :  $V_{DD} = V_{DD1}$ ,  $V_{OUT} = V_{OUT1}$ ,

$V_{DD} = 5.5\text{ V}$ :  $V_{DD} = V_{DD2}$ ,  $V_{OUT} = V_{OUT2}$

$$PSRR = 20 \log \left( \left| \frac{V_{DD1} - V_{DD2}}{\left( V_{OUT1} - \frac{V_{DD1}}{2} \right) - \left( V_{OUT2} - \frac{V_{DD2}}{2} \right)} \right| \times \frac{R_F + R_S}{R_S} \right)$$

• Input offset voltage ( $V_{IO}$ )

$$V_{IO} = \left( V_{OUT} - \frac{V_{DD}}{2} \right) \times \frac{R_S}{R_F + R_S}$$

2. Common-mode input signal rejection ratio, common-mode input voltage range

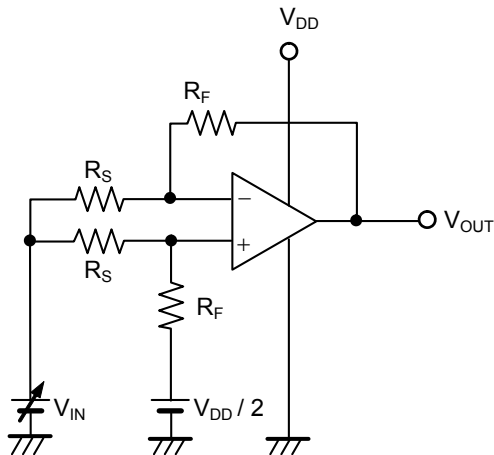

Figure 6

• Common-mode input signal rejection ratio (CMRR)

The common-mode input signal rejection ratio (CMRR) can be calculated by the following expression, with  $V_{OUT}$  measured at each  $V_{IN}$ .

Test conditions:

$V_{IN} = V_{CMR\ Max.}$ :  $V_{IN} = V_{IN1}$ ,  $V_{OUT} = V_{OUT1}$ ,

$V_{IN} = V_{CMR\ Min.}$ :  $V_{IN} = V_{IN2}$ ,  $V_{OUT} = V_{OUT2}$

$$CMRR = 20 \log \left( \left| \frac{V_{IN1} - V_{IN2}}{V_{OUT1} - V_{OUT2}} \right| \times \frac{R_F + R_S}{R_S} \right)$$

• Common-mode input voltage range ( $V_{CMR}$ )

The common mode input voltage range ( $V_{CMR}$ ) is the range of  $V_{IN}$  in which the common mode input signal rejection ratio (CMRR) is satisfied when  $V_{IN}$  is varied.

3. Maximum output swing voltage ( $V_{OH}$ )

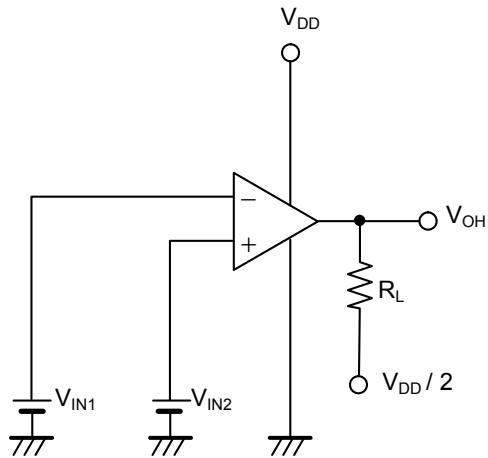

Figure 7

• Maximum output swing voltage ( $V_{OH}$ )

Test conditions

$$V_{IN1} = \frac{V_{DD}}{2} - 0.1 \text{ V}$$

$$V_{IN2} = \frac{V_{DD}}{2} + 0.1 \text{ V}$$

$$R_L = 1 \text{ M}\Omega$$

4. Maximum output swing voltage ( $V_{OL}$ )

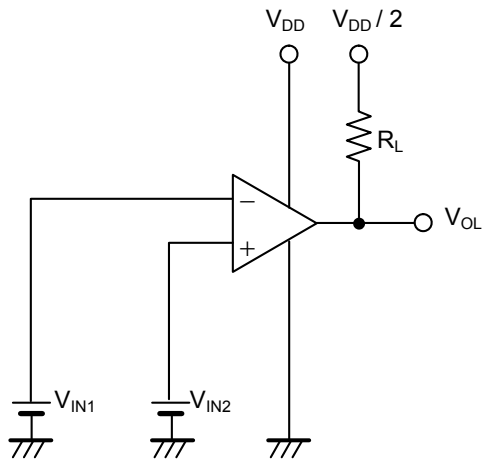

Figure 8

• Maximum output swing voltage ( $V_{OL}$ )

Test conditions:

$$V_{IN1} = \frac{V_{DD}}{2} + 0.1 \text{ V}$$

$$V_{IN2} = \frac{V_{DD}}{2} - 0.1 \text{ V}$$

$$R_L = 1 \text{ M}\Omega$$

5. Current consumption

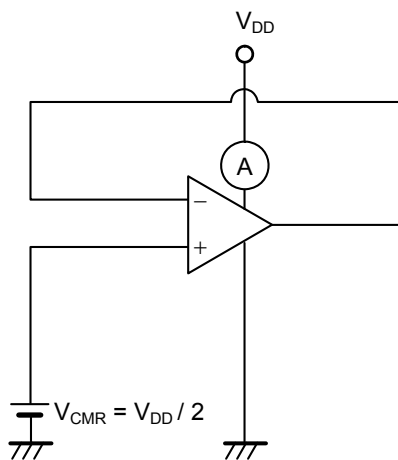

Figure 9

• Current consumption ( $I_{DD}$ )

6. Source current

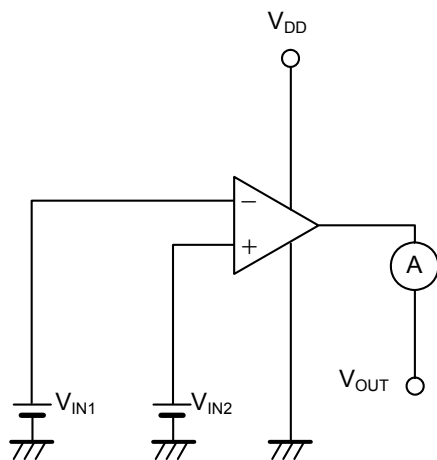

Figure 10

• Source current ( $I_{SOURCE}$ )

Test conditions:

$$V_{OUT} = V_{DD} - 0.12 \text{ V}$$

$$V_{IN1} = \frac{V_{DD}}{2} - 0.1 \text{ V}$$

$$V_{IN2} = \frac{V_{DD}}{2} + 0.1 \text{ V}$$

7. Sink current

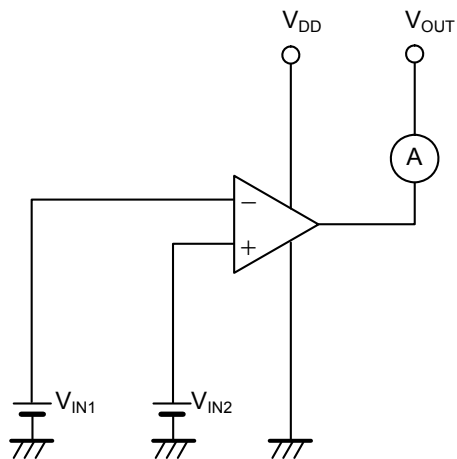

Figure 11

• Sink current ( $I_{SINK}$ )

Test conditions:

$$V_{OUT} = V_{SS} + 0.12 \text{ V}$$

$$V_{IN1} = \frac{V_{DD}}{2} + 0.1 \text{ V}$$

$$V_{IN2} = \frac{V_{DD}}{2} - 0.1 \text{ V}$$

8. Voltage gain (open loop)

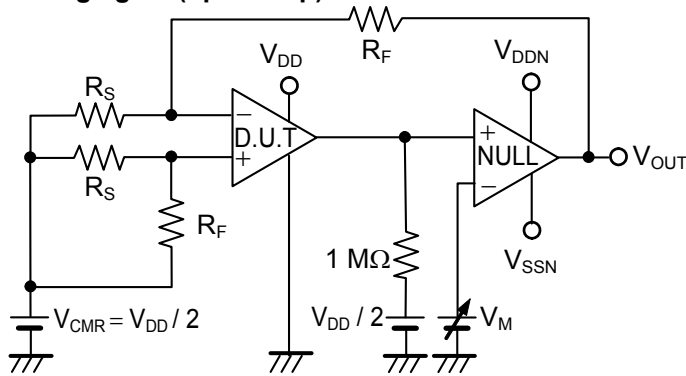

Figure 12

• Voltage-gain (open loop) ( $A_{VOL}$ )

The voltage gain ( $A_{VOL}$ ) can be calculated by the following expression, with measured  $V_{OUT}$  at each  $V_M$ .

Test conditions:

$$V_M = V_{DD} - 0.5 \text{ V}: V_M = V_{M1}, V_{OUT} = V_{OUT1},$$

$$V_M = 0.5 \text{ V}: V_M = V_{M2}, V_{OUT} = V_{OUT2}$$

$$A_{VOL} = 20 \log \left( \left| \frac{V_{M1} - V_{M2}}{V_{OUT1} - V_{OUT2}} \right| \times \frac{R_F + R_S}{R_S} \right)$$

9. Slew rate (SR)

Measured by the voltage follower circuit.

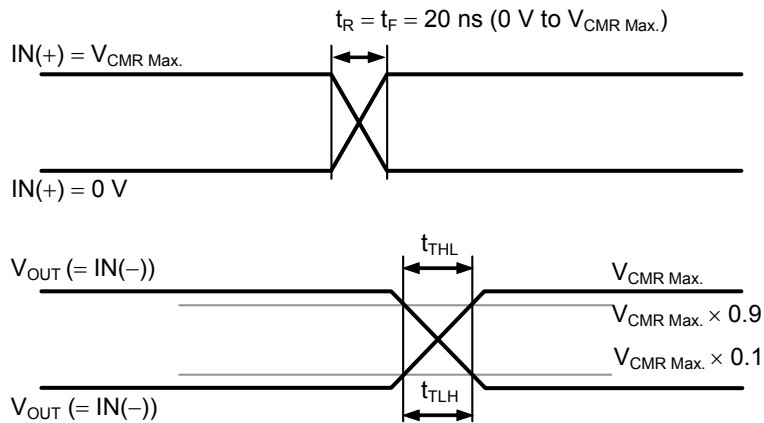

Figure 13

$$SR = \frac{V_{CMR \text{ Max.}} \times 0.8}{t_{TLH}}$$

$$SR = \frac{V_{CMR \text{ Max.}} \times 0.8}{t_{TLH}}$$

■ **Precautions**

- Do not apply an electrostatic discharge to this IC that exceeds performance ratings of the built-in electrostatic protection circuit.
- ABLIC Inc. claims no responsibility for any disputes arising out of or in connection with any infringement by products including this IC of patents owned by a third party.
- Use this IC with the output current 20 mA or less.
- This IC operates stably even directly connecting a load capacitance 100 pF or less to the output pin, as seen in **Figure 14**. When using a load capacitance 100 pF or larger, set a resistor 47 Ω or more, as seen in **Figure 15**. In case of connecting a filter for noise prevention, and using a load capacitance 100 pF or more, also set a resistor 47 Ω or more as seen in **Figure 16**.

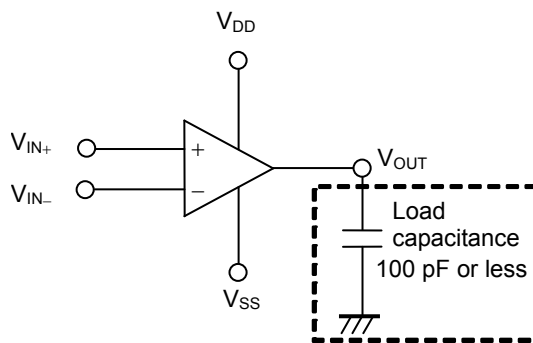

**Figure 14**

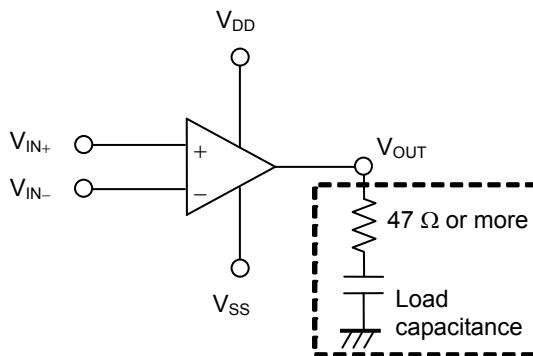

**Figure 15**

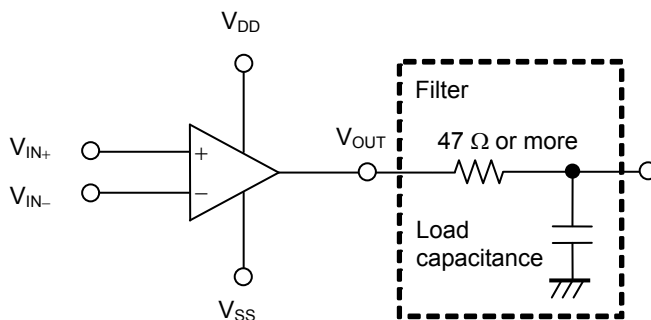

**Figure 16**

**Caution** The above connection diagram and constant will not guarantee successful operation. Perform through evaluation using the actual application to set the constant.

**■ Characteristics (Typical Data)**

**1. Current consumption (per circuit) vs. Power supply voltage**

**1.1 S-89130 Series**

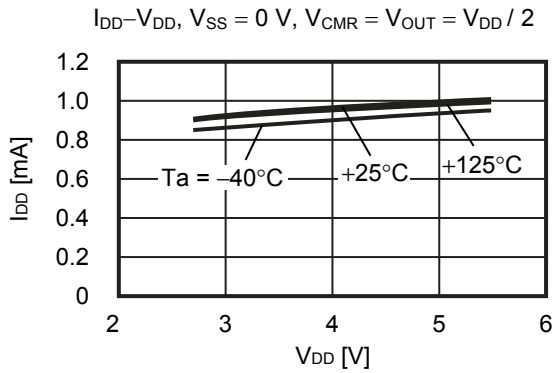

**1.2 S-89140 Series**

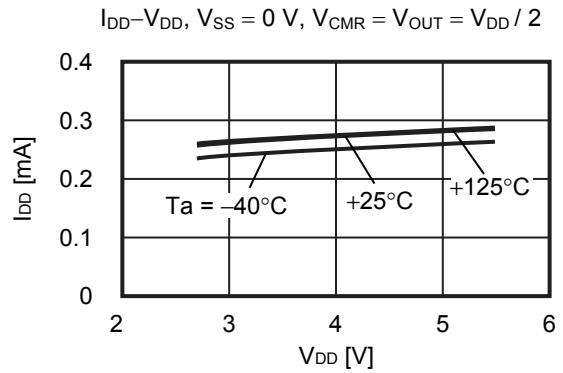

**2. Voltage gain vs. Frequency**

**2.1 S-89130 Series**

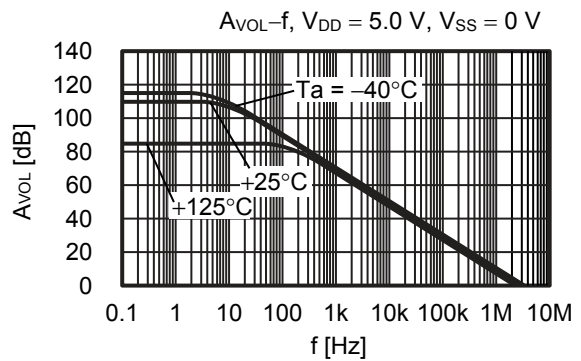
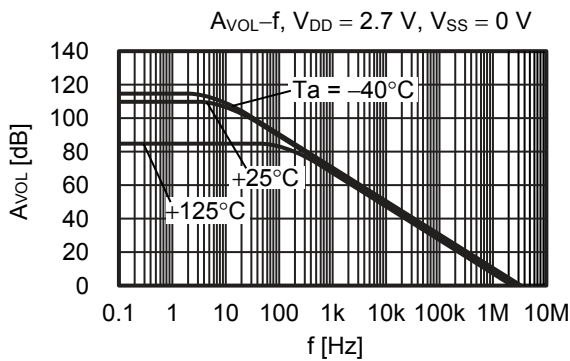

**2.2 S-89140 Series**

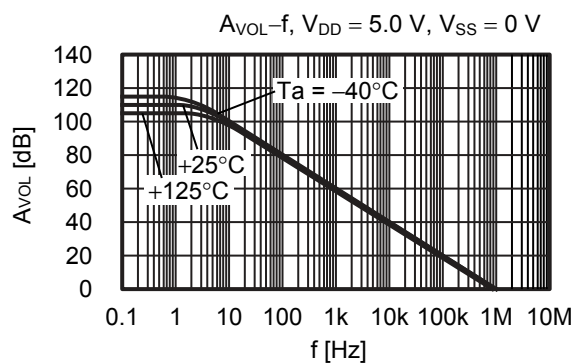
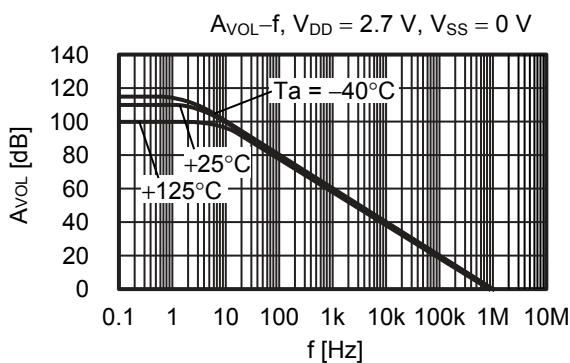

**3. Output current**

**3.1  $I_{SOURCE}$  vs. Power supply voltage**

**3.1.1 S-89130 Series**

$I_{SOURCE} = V_{DD}$ ,  $V_{OUT} = V_{DD} - 0.12\text{ V}$ ,  $V_{SS} = 0\text{ V}$

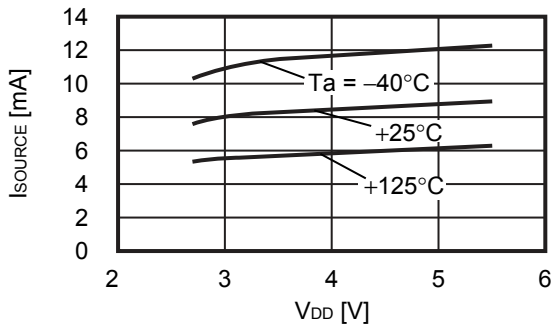

**3.1.2 S-89140 Series**

$I_{SOURCE} = V_{DD}$ ,  $V_{OUT} = V_{DD} - 0.12\text{ V}$ ,  $V_{SS} = 0\text{ V}$

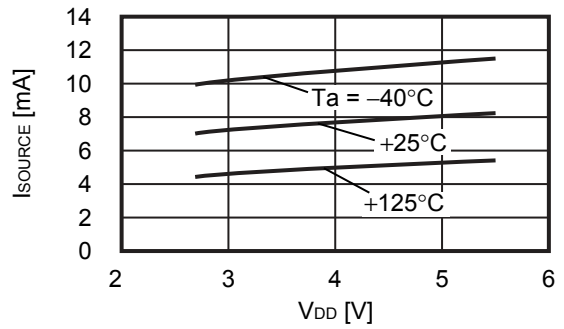

**3.2  $I_{SINK}$  vs. Power supply voltage**

**3.2.1 S-89130 Series**

$I_{SINK} = V_{DD}$ ,  $V_{OUT} = 0.12\text{ V}$ ,  $V_{SS} = 0\text{ V}$

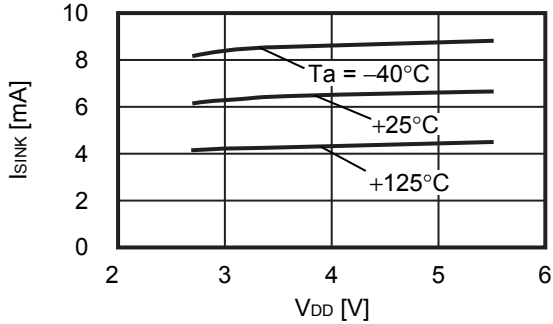

**3.2.2 S-89140 Series**

$I_{SINK} = V_{DD}$ ,  $V_{OUT} = 0.12\text{ V}$ ,  $V_{SS} = 0\text{ V}$

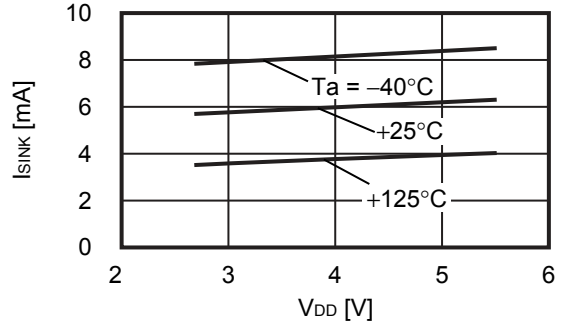

**3.3 Output voltage ( $V_{OUT}$ ) vs.  $I_{SOURCE}$**

**3.3.1 S-89130 Series**

$V_{OUT} = I_{SOURCE}$ ,  $V_{DD} = 2.7\text{ V}$ ,  $V_{SS} = 0\text{ V}$

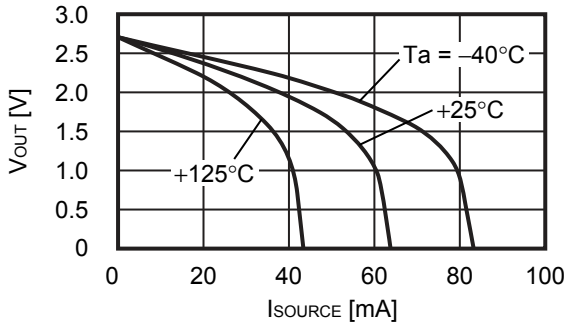

$V_{OUT} = I_{SOURCE}$ ,  $V_{DD} = 5.0\text{ V}$ ,  $V_{SS} = 0\text{ V}$

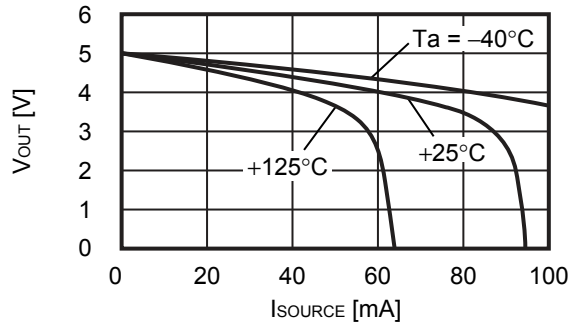



**3.3.2 S-89140 Series**

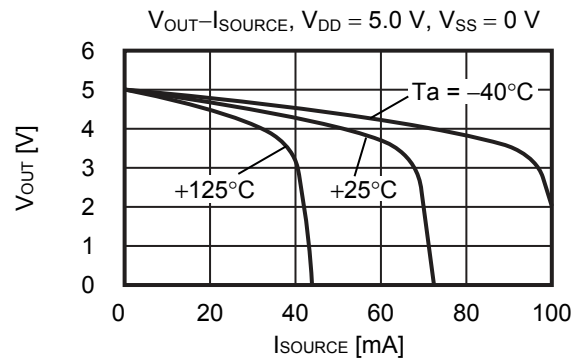
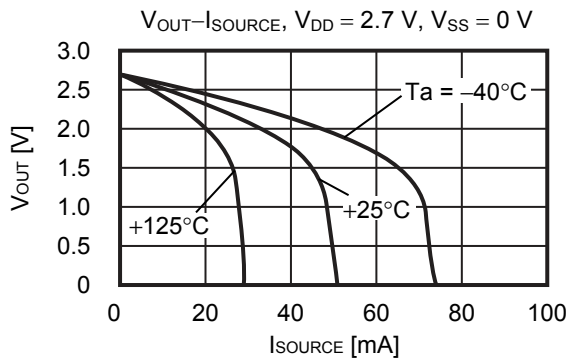

**3.4 Output voltage ( $V_{OUT}$ ) vs.  $I_{SINK}$**

**3.4.1 S-89130 Series**

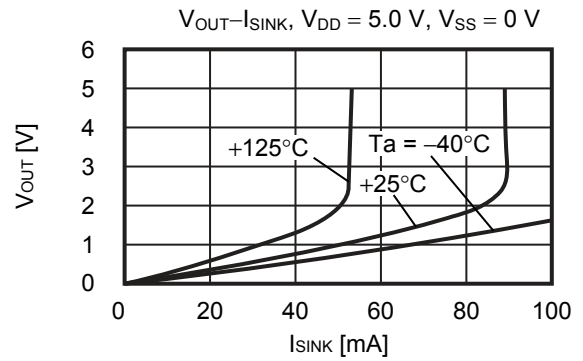
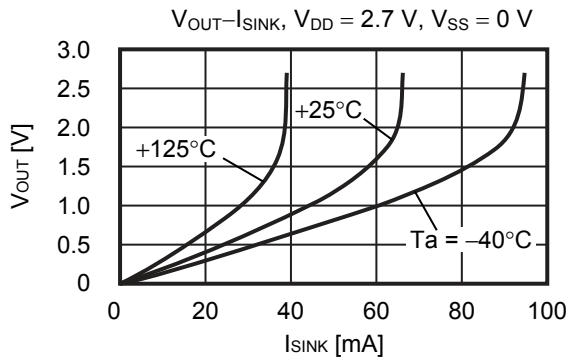

**3.4.2 S-89140 Series**

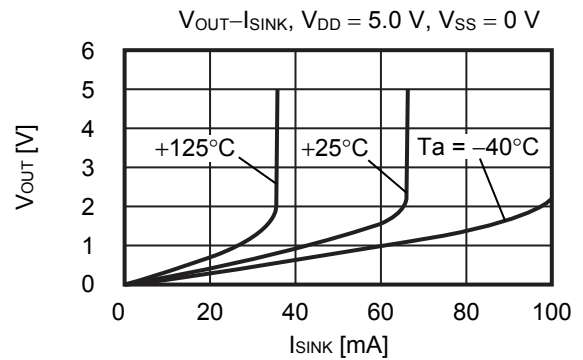
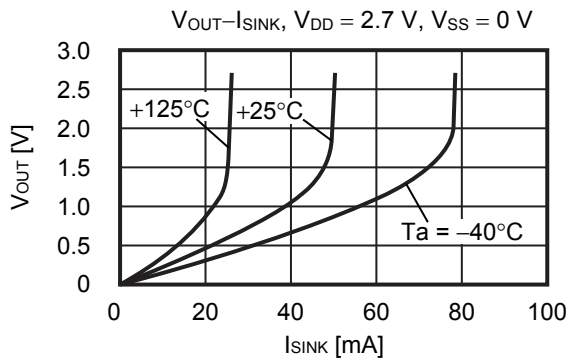

4. Input bias current vs. Temperature

$I_{BIAS}-T_a$ ,  $V_{DD} = 5.0\text{ V}$ ,  $V_{SS} = 0\text{ V}$ ,  $V_{CMR} = V_{DD} / 2$

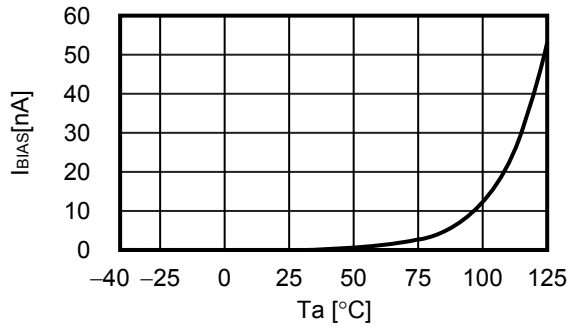

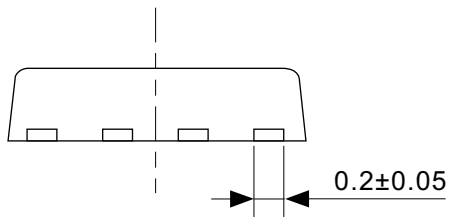
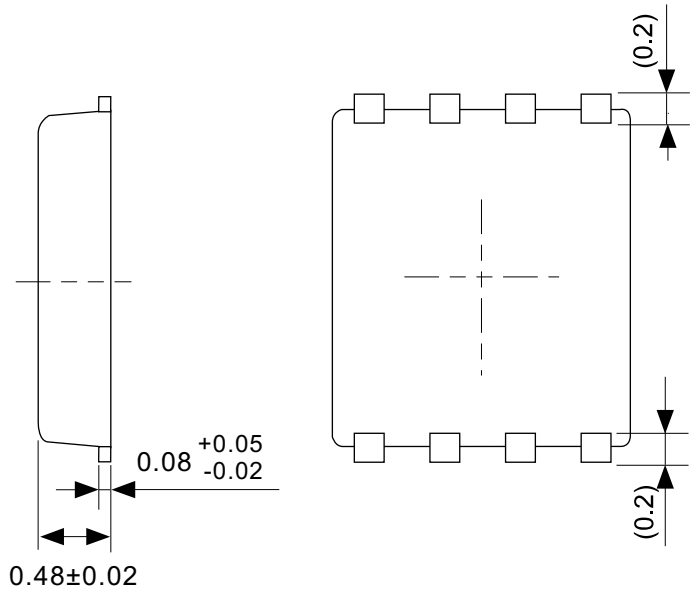
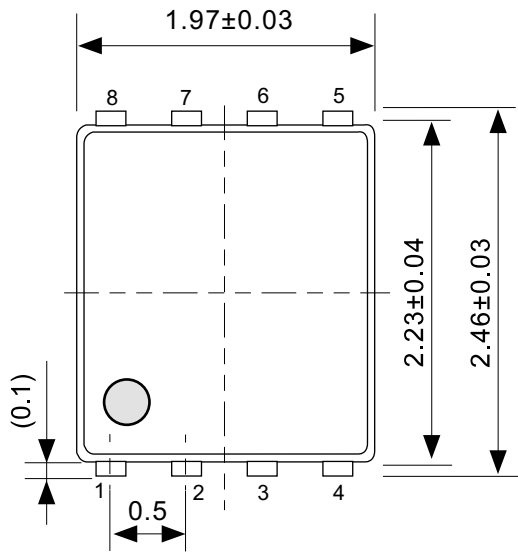

No. PH008-A-P-SD-2.1

TITLE	SNT-8A-A-PKG Dimensions
No.	PH008-A-P-SD-2.1
ANGLE	
UNIT	mm
<b>ABLIC Inc.</b>	

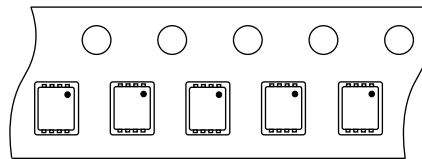
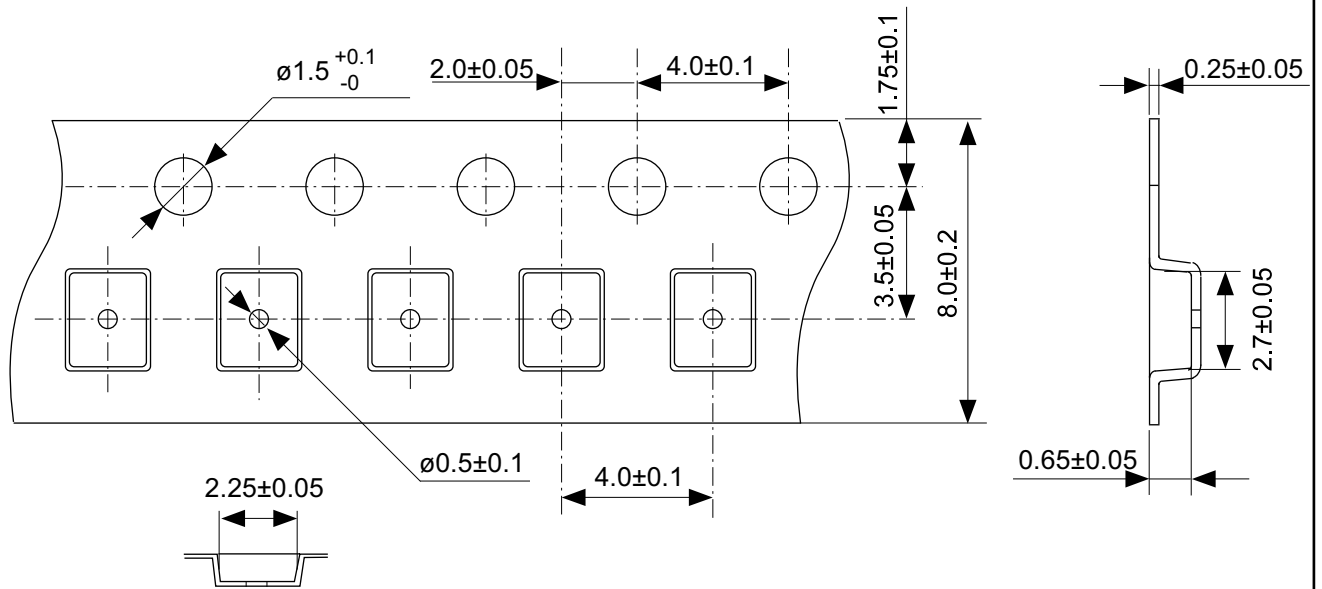

Feed direction

No. PH008-A-C-SD-2.0

TITLE	SNT-8A-A-Carrier Tape
No.	PH008-A-C-SD-2.0
ANGLE	
UNIT	mm
<b>ABLIC Inc.</b>	

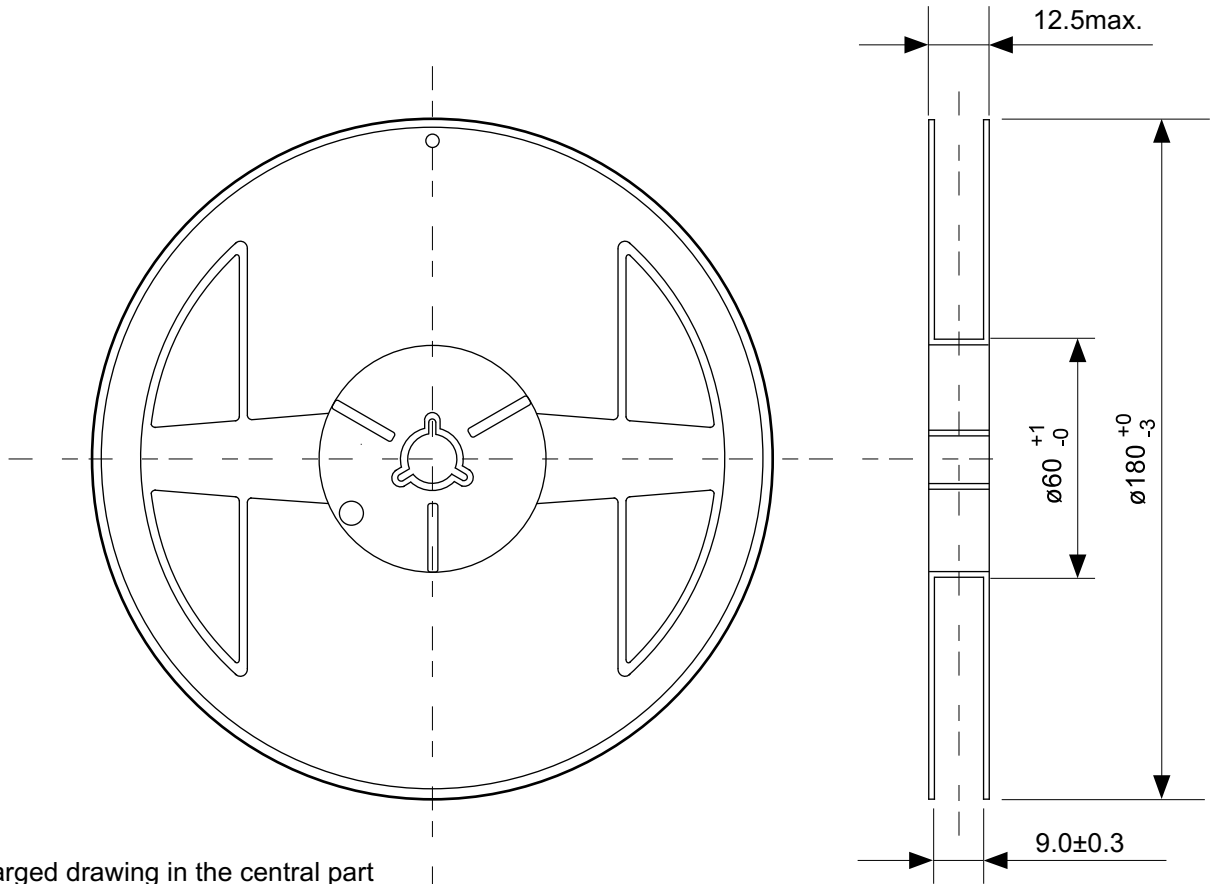

Enlarged drawing in the central part

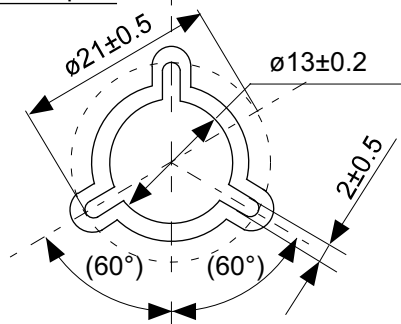

No. PH008-A-R-SD-1.0

TITLE	SNT-8A-A-Reel		
No.	PH008-A-R-SD-1.0		
ANGLE		QTY.	5,000
UNIT	mm		
<b>ABLIC Inc.</b>			

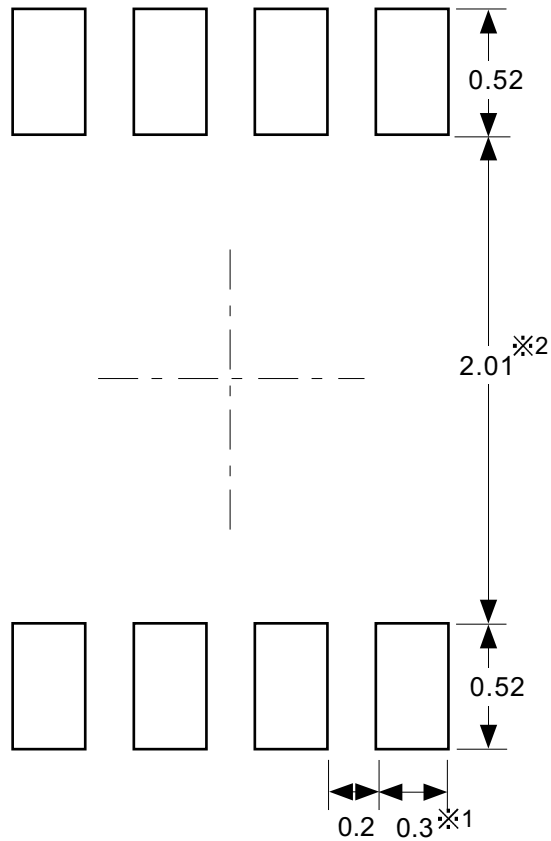

※1. ランドパターンの幅に注意してください (0.25 mm min. / 0.30 mm typ.).  
 ※2. パッケージ中央にランドパターンを広げないでください (1.96 mm ~ 2.06 mm)。

- 注意
1. パッケージのモールド樹脂下にシルク印刷やハンダ印刷などしないでください。
  2. パッケージ下の配線上のソルダーレジストなどの厚みをランドパターン表面から0.03 mm以下にしてください。
  3. マスク開口サイズと開口位置はランドパターンと合わせてください。
  4. 詳細は“SNTパッケージ活用の手引き”を参照してください。

※1. Pay attention to the land pattern width (0.25 mm min. / 0.30 mm typ.).  
 ※2. Do not widen the land pattern to the center of the package (1.96 mm to 2.06mm).

- Caution**
1. Do not do silkscreen printing and solder printing under the mold resin of the package.
  2. The thickness of the solder resist on the wire pattern under the package should be 0.03 mm or less from the land pattern surface.
  3. Match the mask aperture size and aperture position with the land pattern.
  4. Refer to "SNT Package User's Guide" for details.

※1. 请注意焊盘模式的宽度 (0.25 mm min. / 0.30 mm typ.).  
 ※2. 请勿向封装中间扩展焊盘模式 (1.96 mm ~ 2.06 mm)。

- 注意
1. 请勿在树脂型封装的下面印刷丝网、焊锡。
  2. 在封装下、布线上的阻焊膜厚度 (从焊盘模式表面起) 请控制在 0.03 mm 以下。
  3. 钢网的开口尺寸和开口位置请与焊盘模式对齐。
  4. 详细内容请参阅 "SNT 封装的应用指南"。

No. PH008-A-L-SD-4.1

TITLE	SNT-8A-A -Land Recommendation
No.	PH008-A-L-SD-4.1
ANGLE	
UNIT	mm
<b>ABLIC Inc.</b>	

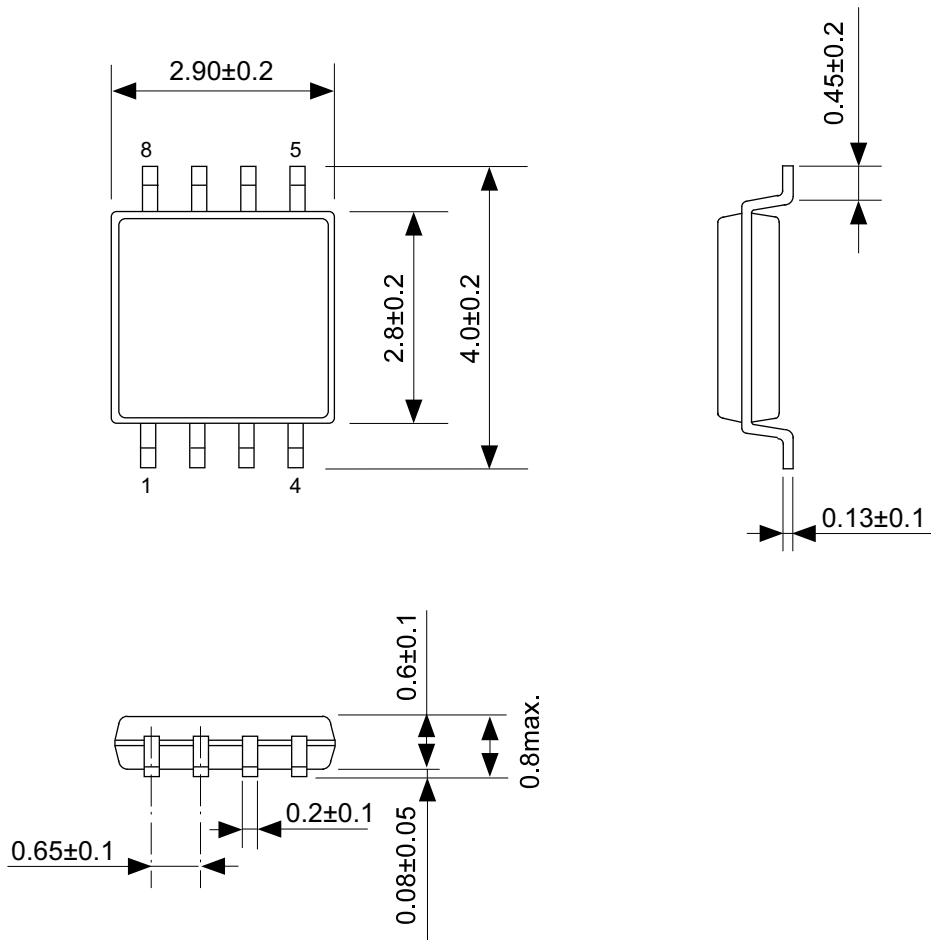

No. FM008-A-P-SD-1.2

TITLE	TMSOP8-A-PKG Dimensions
No.	FM008-A-P-SD-1.2
ANGLE	
UNIT	mm
<b>ABLIC Inc.</b>	

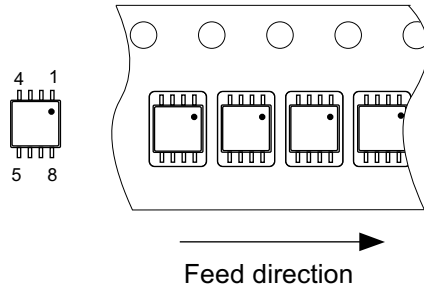
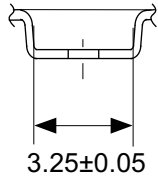
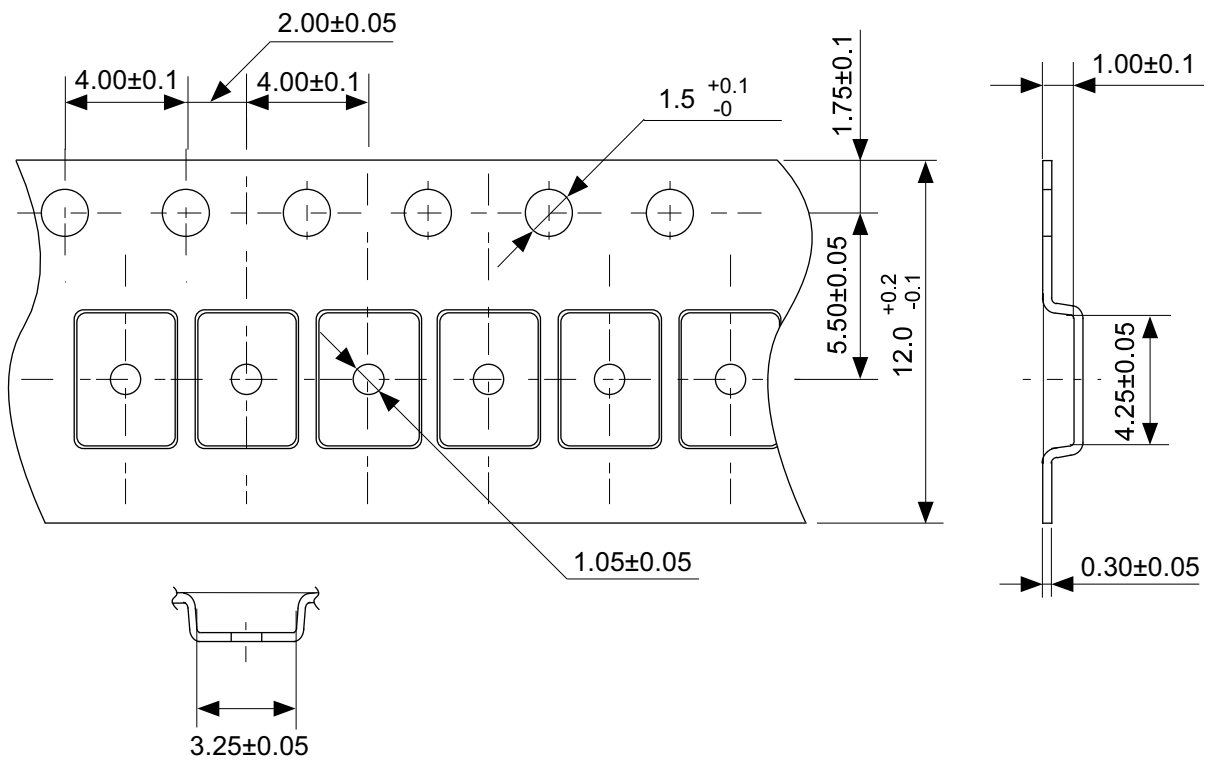

No. FM008-A-C-SD-2.0

TITLE	TMSOP8-A-Carrier Tape
No.	FM008-A-C-SD-2.0
ANGLE	
UNIT	mm
<b>ABLIC Inc.</b>	



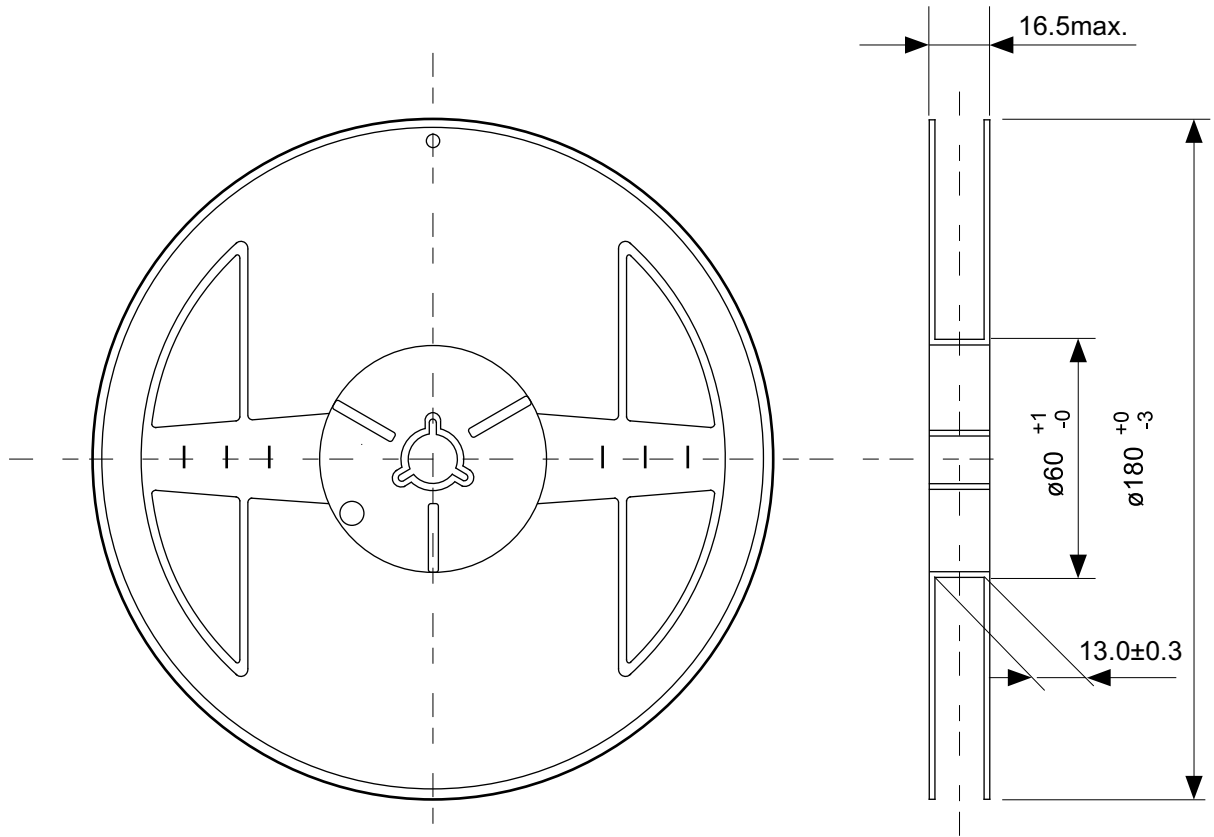

Enlarged drawing in the central part

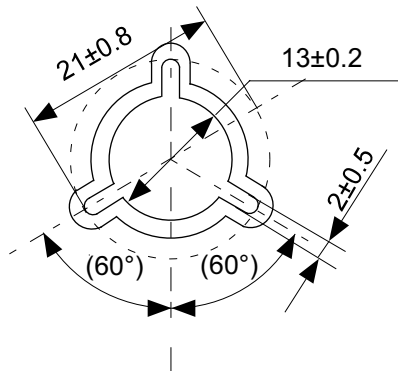

No. FM008-A-R-SD-1.0

TITLE	TMSOP8-A-Reel		
No.	FM008-A-R-SD-1.0		
ANGLE		QTY.	4,000
UNIT	mm		
<b>ABLIC Inc.</b>			

## Disclaimers (Handling Precautions)

1. All the information described herein (product data, specifications, figures, tables, programs, algorithms and application circuit examples, etc.) is current as of publishing date of this document and is subject to change without notice.
2. The circuit examples and the usages described herein are for reference only, and do not guarantee the success of any specific mass-production design.  
ABLIC Inc. is not liable for any losses, damages, claims or demands caused by the reasons other than the products described herein (hereinafter "the products") or infringement of third-party intellectual property right and any other right due to the use of the information described herein.
3. ABLIC Inc. is not liable for any losses, damages, claims or demands caused by the incorrect information described herein.
4. Be careful to use the products within their ranges described herein. Pay special attention for use to the absolute maximum ratings, operation voltage range and electrical characteristics, etc.  
ABLIC Inc. is not liable for any losses, damages, claims or demands caused by failures and / or accidents, etc. due to the use of the products outside their specified ranges.
5. Before using the products, confirm their applications, and the laws and regulations of the region or country where they are used and verify suitability, safety and other factors for the intended use.
6. When exporting the products, comply with the Foreign Exchange and Foreign Trade Act and all other export-related laws, and follow the required procedures.
7. The products are strictly prohibited from using, providing or exporting for the purposes of the development of weapons of mass destruction or military use. ABLIC Inc. is not liable for any losses, damages, claims or demands caused by any provision or export to the person or entity who intends to develop, manufacture, use or store nuclear, biological or chemical weapons or missiles, or use any other military purposes.
8. The products are not designed to be used as part of any device or equipment that may affect the human body, human life, or assets (such as medical equipment, disaster prevention systems, security systems, combustion control systems, infrastructure control systems, vehicle equipment, traffic systems, in-vehicle equipment, aviation equipment, aerospace equipment, and nuclear-related equipment), excluding when specified for in-vehicle use or other uses by ABLIC, Inc. Do not apply the products to the above listed devices and equipments.  
ABLIC Inc. is not liable for any losses, damages, claims or demands caused by unauthorized or unspecified use of the products.
9. In general, semiconductor products may fail or malfunction with some probability. The user of the products should therefore take responsibility to give thorough consideration to safety design including redundancy, fire spread prevention measures, and malfunction prevention to prevent accidents causing injury or death, fires and social damage, etc. that may ensue from the products' failure or malfunction.  
The entire system in which the products are used must be sufficiently evaluated and judged whether the products are allowed to apply for the system on customer's own responsibility.
10. The products are not designed to be radiation-proof. The necessary radiation measures should be taken in the product design by the customer depending on the intended use.
11. The products do not affect human health under normal use. However, they contain chemical substances and heavy metals and should therefore not be put in the mouth. The fracture surfaces of wafers and chips may be sharp. Be careful when handling these with the bare hands to prevent injuries, etc.
12. When disposing of the products, comply with the laws and ordinances of the country or region where they are used.
13. The information described herein contains copyright information and know-how of ABLIC Inc. The information described herein does not convey any license under any intellectual property rights or any other rights belonging to ABLIC Inc. or a third party. Reproduction or copying of the information from this document or any part of this document described herein for the purpose of disclosing it to a third-party is strictly prohibited without the express permission of ABLIC Inc.
14. For more details on the information described herein or any other questions, please contact ABLIC Inc.'s sales representative.
15. This Disclaimers have been delivered in a text using the Japanese language, which text, despite any translations into the English language and the Chinese language, shall be controlling.

2.4-2019.07