

PAGE 1/2

ISSUE 24-11-16

SERIE : SPnT

PART NUMBER : R574303425

RF CHARACTERISTICS

Number of ways : **4**
 Frequency range : **0 - 3 GHz**
 Impedance : **50 Ohms**

Frequency (GHz)	DC - 3
VSWR max	1.20
Insertion loss max	0.20 dB
Isolation min	80 dB
Average power (*)	240 W

TERMINATION IMPEDANCE : **50 Ohms**
 TERM. AVG. POWER AT 25° C : **1 W per termination / 3 W total power**

ELECTRICAL CHARACTERISTICS

Actuator : **NORMALLY OPEN**
 Nominal current ** : **102 mA**
 Actuator voltage (Vcc) : **28V (24 to 30V)**
 Terminals : **25 pins D-SUB male connector**
 TTL inputs (E) - High level : **2.2 to 5.5 V / 800µA at 5.5 V**
 - Low level : **0 to 0.8 V / 20µA at 0.8 V**

MECHANICAL CHARACTERISTICS

Connectors : **SMA female per MIL-C 39012**
 Life : **2.000.000 cycles per position**
 Switching Time*** : **< 15 ms**
 Construction : **Splashproof**
 Weight : **< 250 g**

ENVIRONMENTAL CHARACTERISTICS

Operating temperature range : **-40°C to +85°C**
 Storage temperature range : **-55°C to +85°C**

(* Average power at 25°C per RF Path)
 (** At 25° C ±10%)
 (***) Nominal voltage ; 25° C)



PAGE 2/2

ISSUE 24-11-16

SERIE : SPnT

PART NUMBER : R574303425

DRAWING

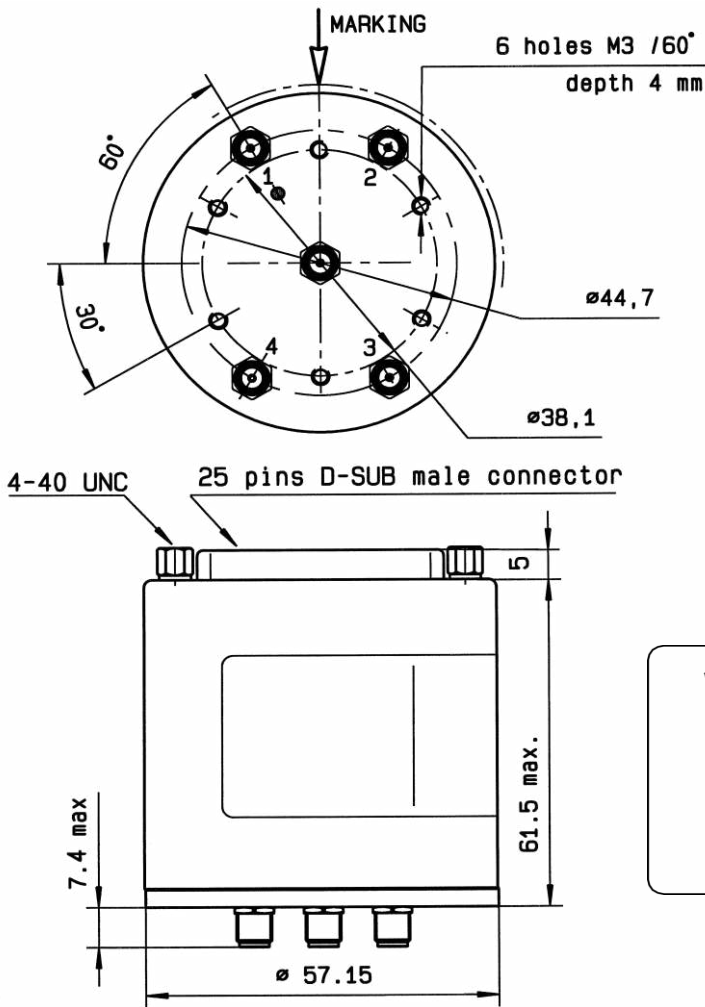

TTL input	RF Continuity
E1 = 1	IN ↔ 1
E2 = 1	IN ↔ 2
E3 = 1	IN ↔ 3
E4 = 1	IN ↔ 4

LABEL

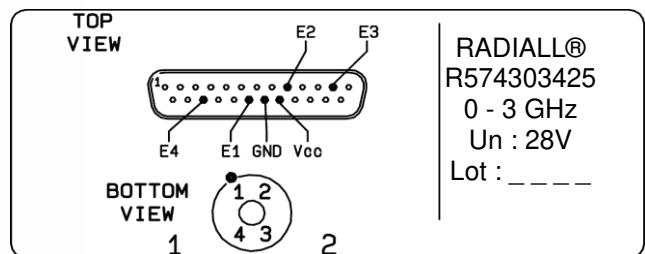

General tolerances : ±0.5 mm

SCHEMATIC DIAGRAM

