

AS1702/3/4/5

Demoboard Application Note

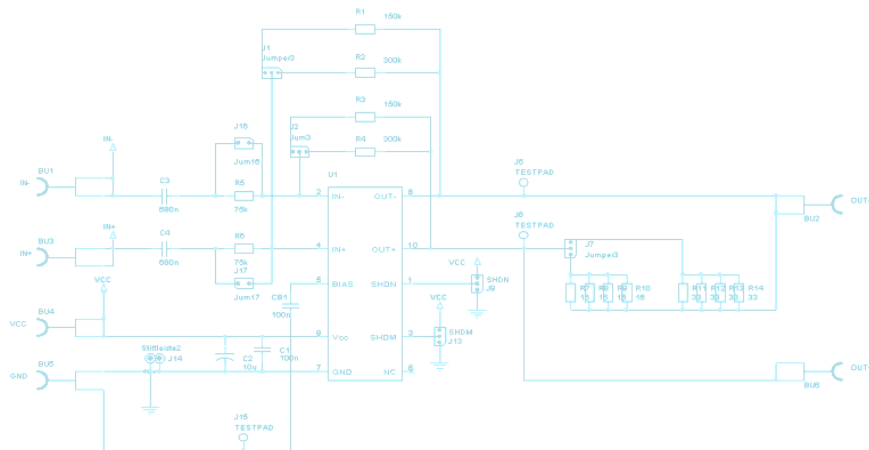
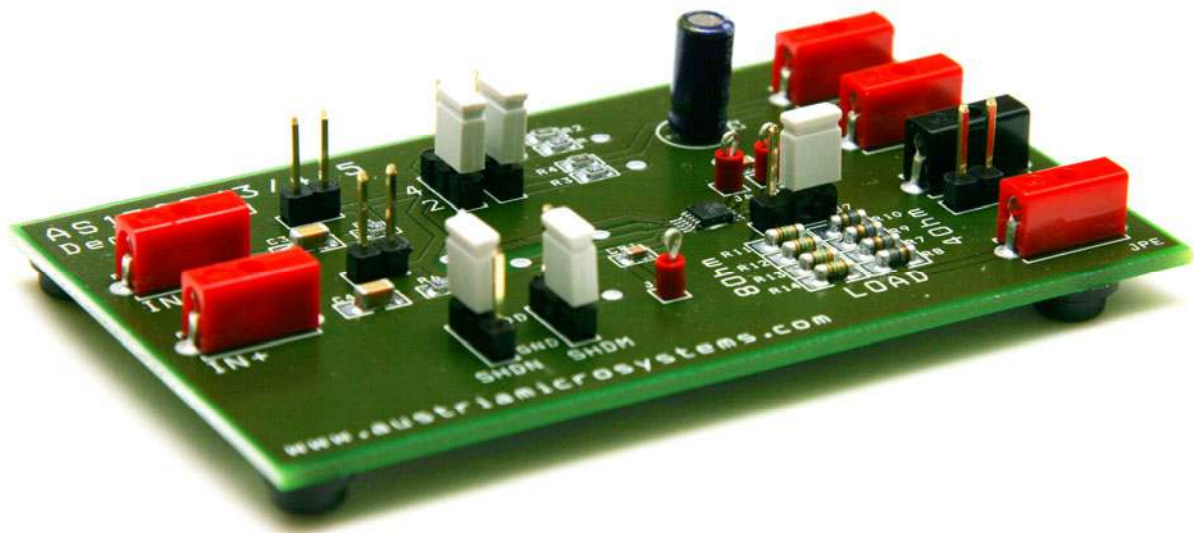

General Description

Jumper Description

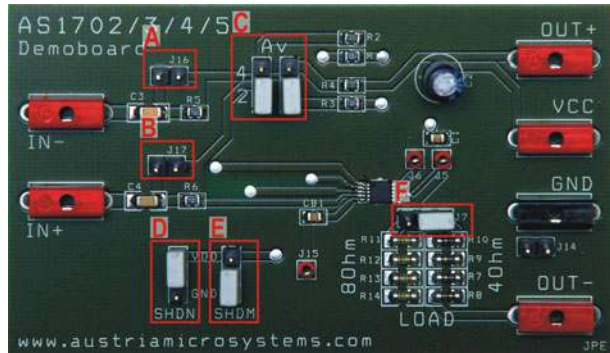

Mark	Jumper	Description	Set	Not Set
A	J16	R_{IN} of IN-	R_{IN} disabled	R_{IN} enabled
B	J17	R_{IN} of IN+	R_{IN} disabled	R_{IN} enabled
C	Av	Gain of the Amplifier*	Av = 2 Av = 4	For AS1703/04/05 only
D	SHDN	Shutdown	or Shutdown Mode enabled,	Not recommended
E	SHDM	Shutdown Mode	or Normal Operation enabled	
F	J7	Output Impedance	Load = 80Ohm Load = 40Ohm	Load = 0Ohm

*) Gain settings only applicable for AS1702

Measurement Points Description

Mark	Pin	Description
G	J14	Ground
H	J15	Measurement Point of BIAS-GND
I	J6	Measurement Point of OUT+
J	J5	Measurement Point of OUT-

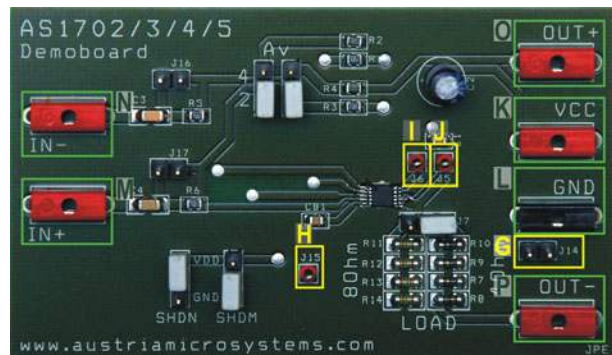

Input/Output Description

Mark	Connector	Description
K	VCC	Power Supply Connectors for VCC and GND.
L	GND	
M	IN+	Input Connectors for differential signal source.
N	IN-	
O	OUT+	Outputs Connectors.
P	OUT-	

Demoboard Application Note

Circuit

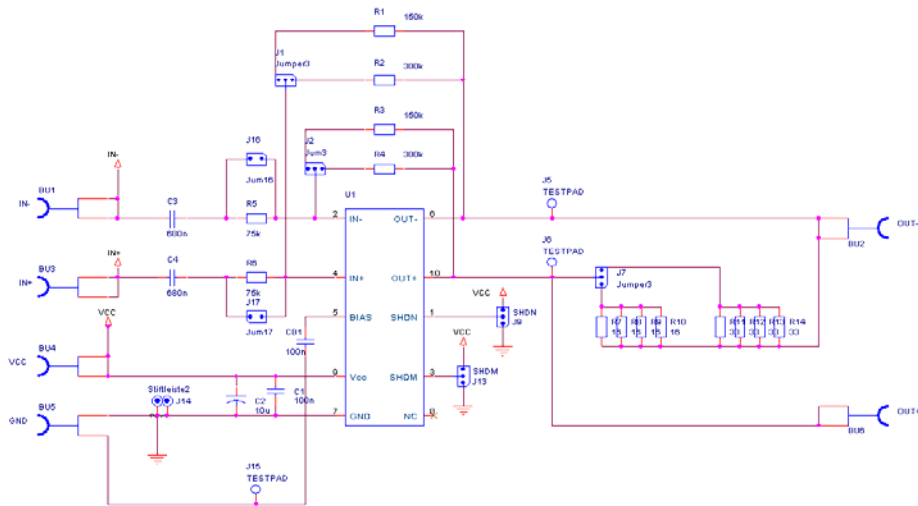

Starting Up

Soldered Chip

The AS1702/3/4/5 demo board is designed to work with the AS1702, AS1703, AS1704 and the AS1705. Before using the Demoboard please make sure which chip is on the board and set the Jumpers appropriate if necessary. The marking of the chip can be found printed on the IC soldered on the board.

Per default an AS1702 is mounted on the Demoboard

Two different Jumper settings are necessary, one for the AS1702 and another for the AS1703/04/05.

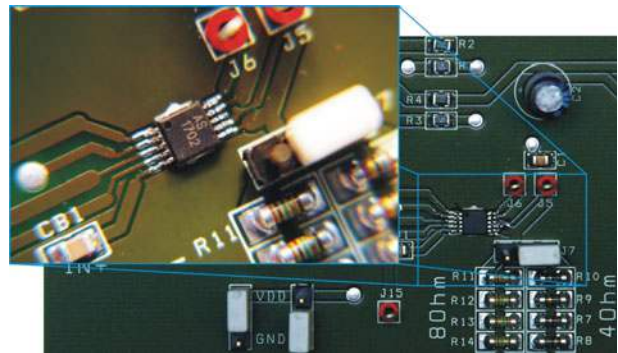

If an AS1703, AS1704, AS1705 is soldered, set the following jumpers:

Mark	Jumper	Description	Jumper Set	Value
A	J16	R_{IN} of IN-	SET	$R_{IN} = 0k\Omega$
B	J17	R_{IN} of IN+	SET	$R_{IN} = 0k\Omega$
C	A_v	Gain of the Amplifier	NOT SET	Gain of IC. See datasheet.
D	SHDN	Shutdown	SET (2 values possible)	VDD/GND
E	SHDM	Shutdown Mode	SET (2 values possible)	VDD/GND
F	J7	Output Impedance	OPTIONAL (3 values possible)	Load = 0 / 4 / 80 Ω

If an AS1702 is soldered, set the following jumpers:

Mark	Jumper	Description	Jumper Set	Value
A	J16	R_{IN} of IN-	NOT SET	$R_{IN} = 75k\Omega$
B	J17	R_{IN} of IN+	NOT SET	$R_{IN} = 75k\Omega$
C	A_v	Gain of the Amplifier	SET (2 values possible)	$A_v = 2 / 4$ (6dB / 12dB)
D	SHDN	Shutdown	SET (2 values possible)	VDD/GND
E	SHDM	Shutdown Mode	SET (2 values possible)	VDD/GND
F	J7	Output Impedance	OPTIONAL (3 values possible)	Load = 0 / 4 / 80 Ω

Operational sequence

1. If not present get the datasheet for the AS1702/03/04/05 from www.austriamicrosystems.com. Drive the IC on the Demoboard only with the recommended settings and values as described in the datasheet.
2. Make sure which IC is soldered on the Demoboard.
3. Set Jumper as described above.
 - Choose an output impedance.
 - Choose the gain.
4. Connect a 2.7 to 5.5V power supply (VDD and GND).
5. Connect a differential signal source. For example differential sinus signal.
6. Measure on the measuring points J6(OUT+) and J5(OUT-) and J15(BIAS-GND).

Note: It's possible to connect headphones or speakers (40hm or 80hm Impedance) to the outputs. Make sure the onboard Output Impedance is set to 0Ohm with removing Jumper J7 (F).

Have fun using the Demoboard. If there are questions do not hesitate to contact us. See contact information below.

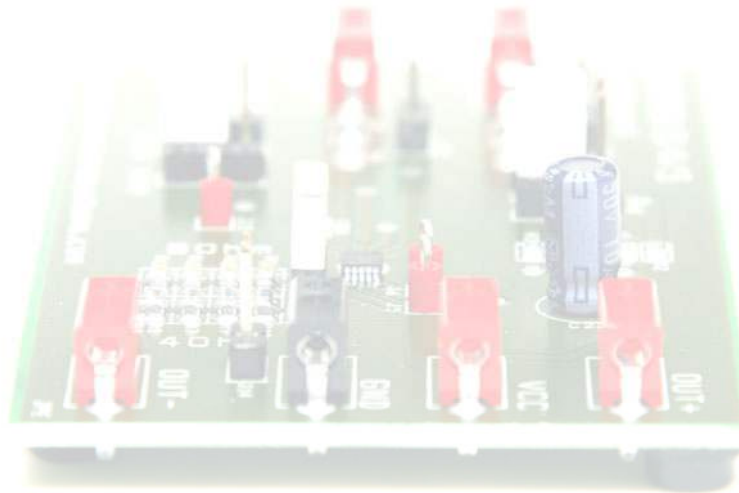

Copyright

Copyright © 2005 austriamicrosystems. Trademarks registered ®. All rights reserved. The material herein may not be reproduced, adapted, merged, translated, stored, or used without the prior written consent of the copyright owner. To the best of its knowledge, austriamicrosystems asserts that the information contained in this publication is accurate and correct.

Contact Information

Headquarters:

austriamicrosystems AG
Standard Linear
A 8141 Schloss Premstätten, Austria
T. +43 (0) 3136 500 0
F. +43 (0) 3136 5692
info@austriamicrosystems.com

For Sales Offices, Distributors and Representatives, please visit: www.austriamicrosystems.com