

SINGLE-POLE SWITCHES

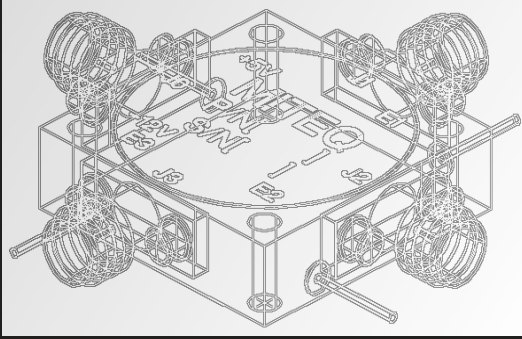

MITEQ offers a broad line of switches covering multioctave bands from 0.2 to 18 GHz. Single-pole, single-throw through single-pole, seven-throw switches are available as standard products. We can, on special request, provide switches up to single-pole, twelve-throw and can array switches to form switch matrices to handle signal routing in complex systems.

Custom switches up to 40 GHz are also available. Our switches can be screened to the salient characteristics of MIL-STD-883 and we offer a variety of connector options including GPO and SMA. Custom high-power switches capable of switching up to 10 watts are also available.

Our standard products achieve switching times as low as two nanoseconds for those applications requiring the ultimate in switching speed. We are able to accommodate special video leakage needs by incorporating video filters and pulse-shaping networks as needed.

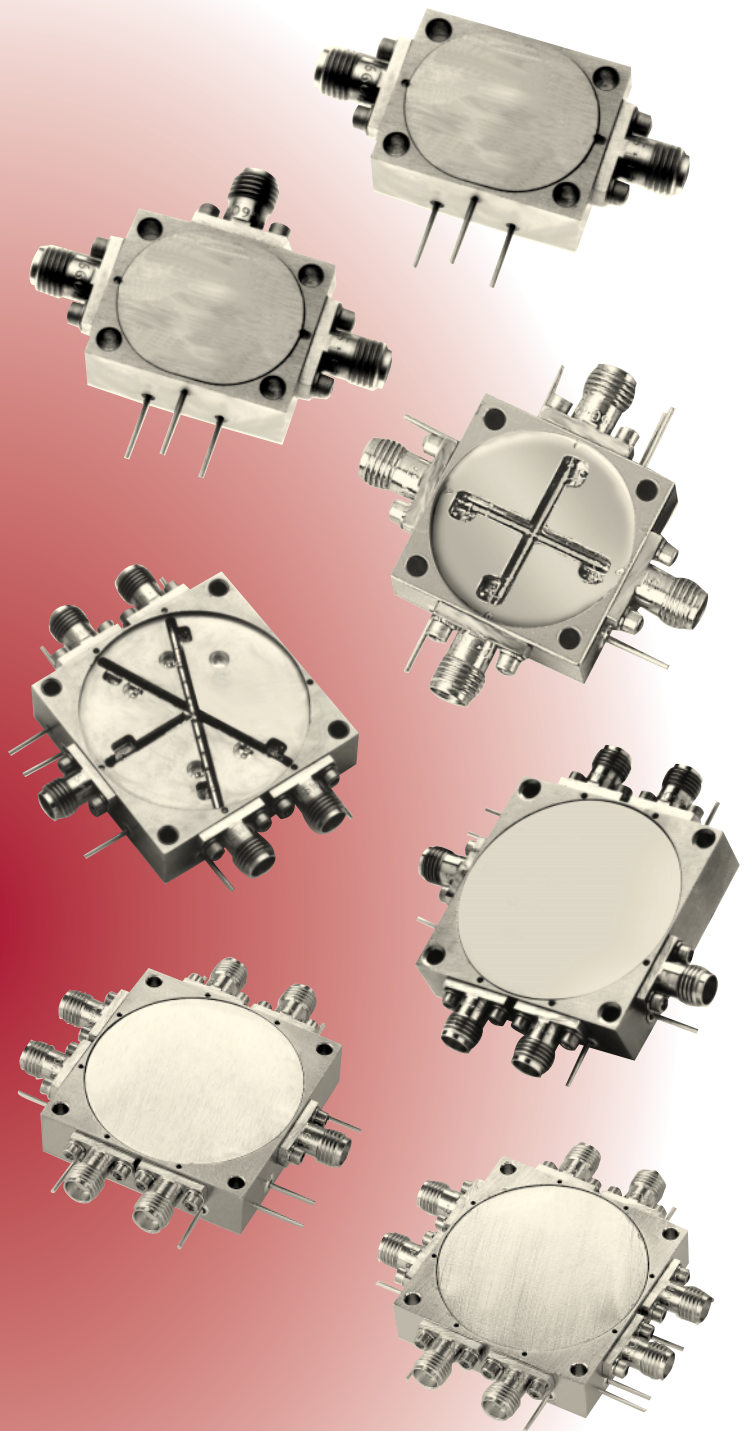

GENERAL SPECIFICATIONS

Power handling (full performance)	20 dBm
Power handling (no damage).....	30 dBm
Video leakage for "F" model (RMS power)	< -50 dBm (> 2 GHz) typical
Third order input intercept point.....	35 dBm typical

ENVIRONMENTAL CONDITIONS

Operating temperature	0 to 70°C
Storage temperature.....	-30 to +85°C
Humidity.....	95% noncondensing
Vibration	12 Gs RMS, 20–2000 Hz per MIL-STD-810B, Method 514, Procedure 5

SINGLE-POLE SINGLE-THROW SWITCHES

FEATURES

- Multioctave bands 0.2 to 18 GHz
- Current and TTL control
- Low loss
- High isolation
- Medium and high speed models
- Drop-in models
- 2 ns models

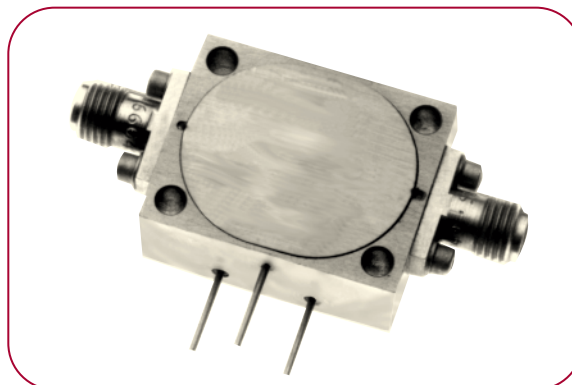

Frequency Range (GHz)	Model Number	Insertion Loss (dB, Max.)	Isolation (dB, Min.)	*VSWR (Max.)	Type (Reflective/Absorptive)	DC Power Consumption		Outline	Ordering Options	Additional Features
						Pos. Supply (mA, Max.)	Neg. Supply (mA, Min.)			
STANDARD, MULTIOCTAVE BAND MODELS										
0.2-2	S103A	1.5	50	1.6:1	Ref	35	35	SPST	1-5	-
	S103B	1.7	70	1.6:1	Ref	35	35	SPST	1-5	-
	N103A	1.6	55	1.6:1	Abs	35	35	SPST	1-5	-
	N103B	1.8	75	1.6:1	Abs	35	35	SPST	1-5	-
0.5-2	S113A	1.3	60	1.6:1	Ref	35	35	SPST	1-6	-
	S113B	1.5	80	1.6:1	Ref	35	35	SPST	1-6	-
	N113A	1.5	55	1.6:1	Abs	35	35	SPST	1-5	-
	N113B	1.7	75	1.6:1	Abs	35	35	SPST	1-5	-
2-8	S136A	1.8	60	1.7:1	Ref	35	35	SPST	1-6	-
	S136B	2	80	1.7:1	Ref	35	35	SPST	1-6	-
	N136A	2	55	1.7:1	Abs	35	35	SPST	1-5	-
	N136B	2.2	70	1.7:1	Abs	35	35	SPST	1-5	-
4-12	S147A	2	70	1.7:1	Ref	35	35	SPST	1-6	-
	S147B	2.2	90	1.7:1	Ref	35	35	SPST	1-6	-
	N147A	2.3	50	1.7:1	Abs	35	35	SPST	1-5	-
	N147B	2.6	65	1.7:1	Abs	35	35	SPST	1-5	-
2-18	S138A	2.6	60	2:1	Ref	35	35	SPST	1-6	-
	S138B	3	80	2:1	Ref	35	35	SPST	1-6	-
	N138A	2.6	45	2:1	Abs	35	35	SPST	1-5	-
	N138B	3	60	2:1	Abs	35	35	SPST	1-5	-
1-18	S128A	2.7	50	2:1	Ref	35	35	SPST	1-5	-
	S128B	3	70	2:1	Ref	35	35	SPST	1-5	-
	N128A	2.8	45	2:1	Abs	35	35	SPST	1-5	-
	N128B	3.2	60	2:1	Abs	35	35	SPST	1-5	-

Electrical performance of multioctave models can be optimized over narrower bandwidths, or for a particular parameter. Electrical options include: Lower insertion loss, lower VSWR, higher isolation, flat amplitude response, amplitude tracking. Mechanical/Control options include: Custom packaging, single supply operation, fast switching time, single TTL control line. Examples of custom models previously shipped are shown below. Consult factory for options.

OPTIMIZED PERFORMANCE MODELS

0.21-0.23	124794	1.8	80	1.6:1	Abs	35	35	SPST	5V,-12V.	
0.5-2	126152	1.1	60	1.6:1	Abs	70	70	Contact factory	5V,-15V. 40ns switch speed	
3-3.4	124516	1	60	1.5:1	Abs	-	-	SPST	5V,-5V. 6ns rise/fall time	
5-5.6	125473	1.3	60	1.5:1	Abs	-	-	SPST	5V,-5V. 6ns rise/fall time	
3-9	123296	1.7	60	1.7:1	Ref	-	-	SPST	5V,-15V. 30ns switch speed	
9.5-10.5	127922	2.5	70	1.7:1	Abs	35	35	SPST	5V,-15V. 5ns rise/fall time	
2-18	124796	3.2	80	2:1	Ref	-	-	SPST	5, -15V. 2ns rise/fall time	
2-18	123297	2.8	70	1.8:1	Ref	50	50	Contact factory	±15V. 4ns rise/fall time	
2-18	122791	3	80	1.8:1	Ref	50	50	Contact factory	5V,-12V. 3ns rise/fall time	
2-18	123797	2.8	70	1.8:1	Ref	50	50	Contact factory	5V,-15V. 4ns rise/fall time	

* For reflective models, VSWR is not specified in the "OFF" state.
For absorptive models, VSWR in the "OFF" state is defined for port J2 only.

SINGLE-POLE DOUBLE-THROW SWITCHES

FEATURES

- Multioctave bands 0.2 to 18 GHz
- Current and TTL control
- Low loss
- High isolation
- Medium and high speed models
- Drop-in models
- Amplitude and phase tracking

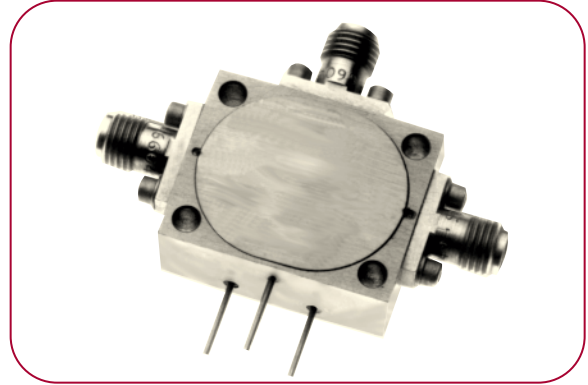

Frequency Range (GHz)	Model Number	Insertion Loss (dB, Max.)	Isolation (dB, Min.)	*VSWR (Max.)	Type (Reflective/Absorptive)	DC Power Consumption Pos. Supply (mA, Max.)	Neg. Supply (mA, Min.)	Outline	Ordering Options	Additional Features
STANDARD, MULTIOCTAVE BAND MODELS										
0.2–2	S203A	1.2	50	1.6:1	Ref	60	60	SP2T	1-5	–
	S203B	1.5	70	1.6:1	Ref	60	60	SP2T	1-5	–
	N203A	1.7	55	1.6:1	Abs	60	60	SP2T	1-5	–
	N203B	2	75	1.6:1	Abs	60	60	SP2T	1-5	–
0.5–2	S213A	1	60	1.6:1	Ref	60	60	SP2T	1-5	–
	S213B	1.3	80	1.6:1	Ref	60	60	SP2T	1-5	–
	N213A	1.5	55	1.6:1	Abs	60	60	SP2T	1-5	–
	N213B	1.8	75	1.6:1	Abs	60	60	SP2T	1-5	–
2–8	S236A	1.6	60	1.7:1	Ref	60	60	SP2T	1-5	–
	S236B	1.8	80	1.7:1	Ref	60	60	SP2T	1-5	–
	N236A	1.8	55	1.7:1	Abs	60	60	SP2T	1-5	–
	N236B	2	70	1.7:1	Abs	60	60	SP2T	1-5	–
4–12	S247A	2	70	1.7:1	Ref	60	60	SP2T	1-5	–
	S247B	2.2	90	1.7:1	Ref	60	60	SP2T	1-5	–
	N247A	2	50	1.7:1	Abs	60	60	SP2T	1-5	–
	N247B	2.2	65	1.7:1	Abs	60	60	SP2T	1-5	–
2–18	S238A	2.5	60	2:1	Ref	60	60	SP2T	1-5	–
	S238B	2.8	80	2:1	Ref	60	60	SP2T	1-5	–
	N238A	2.6	45	2:1	Abs	60	60	SP2T	1-5	–
	N238B	3	60	2:1	Abs	60	60	SP2T	1-5	–
1–18	S228A	2.6	55	2:1	Ref	60	60	SP2T	1-5	–
	S228B	3	70	2:1	Ref	60	60	SP2T	1-5	–
	N228A	2.8	45	2:1	Abs	60	60	SP2T	1-5	–
	N228B	3.2	60	2:1	Abs	60	60	SP2T	1-5	–
Electrical performance of multioctave models can be optimized over narrower bandwidths, or for a particular parameter. Electrical options include: Lower insertion loss, lower VSWR, higher isolation, flat amplitude response, amplitude tracking. Mechanical/Control options include: Custom packaging, single supply operation, fast switching time, single TTL control line. Examples of custom models previously shipped are shown below. Consult factory for options.										
OPTIMIZED PERFORMANCE MODELS										
0.5–2	124513	1.4	70	1.5:1	Ref	–	–	SP2T	50ns switch speed	
0.5–2	126157	1.5	70	1.6:1	Abs	95	95	Contact factory	5V,-12V. 50ns switch speed	
1–2	126158	1.5	70	1.5:1	Ref	90	90	Contact factory	5V,-12V. Single TTL line	
1.2–1.6	122797	2.2	75	1.6:1	Abs	60	60	SP2T	5V,-15V. 50ns switch speed	
0.8–4	126150	1.5	70	1.7:1	Ref	60	60	SP2T	5V,-12V	
8–10	122499	2	60	1.6:1	Ref	–	–	SP2T	5V,-12V. 50ns switch speed	
9–11	126154	2.5	40	1.5:1	Ref	25	–	Contact factory	Single 5V supply	
15–17	125963	3	45	2:1	Ref	60	60	SP2T	5V,-12V. 50ns switch speed	
2–18	124080	2.7	65	2:1	Ref	60	60	SP2T	5V,-12V. 50ns switch speed	
2–18	124784	3	65	2:1	Abs	60	60	SP2T	5V,-12V. Single TTL line	
2–18	127070	2.5	70	1.7:1	Abs	60	60	SP2T	5V,-15V	
23.5–24.5	120612	3	35	2:1	Ref	–	–	SP2T	5V,-12V. 7ns rise/fall time	

* For reflective models, VSWR is not specified in the “OFF” state.
For absorptive models, VSWR in the “OFF” state is defined for port J2 only.

SINGLE-POLE THREE-THROW SWITCHES

FEATURES

- Multioctave bands 0.2 to 18 GHz
- Current and TTL control
- Low loss
- High isolation
- Medium and high speed models
- Drop-in models
- Amplitude and phase tracking
- Binary decoded logic

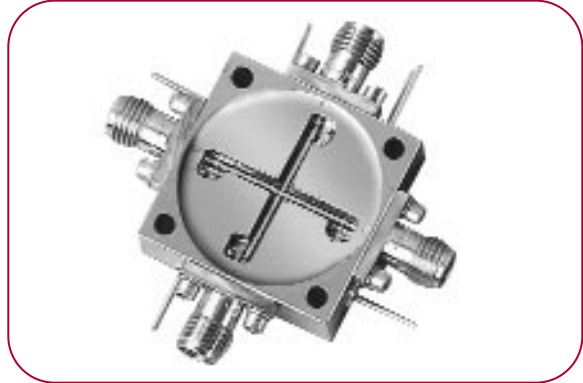

Frequency Range (GHz)	Model Number	Insertion Loss (dB, Max.)	Isolation (dB, Min.)	*VSWR (Max.)	Type (Reflective/Absorptive)	DC Power Consumption Pos. Supply (mA, Max.)	Neg. Supply (mA, Min.)	Outline	Ordering Options	Additional Features
STANDARD, MULTIOCTAVE BAND MODELS										
0.2-2	S303A	1.3	50	1.6:1	Ref	85	85	SP3T	1-5	-
	S303B	1.6	70	1.6:1	Ref	85	85	SP3T	1-5	-
	N303A	1.7	55	1.6:1	Abs	85	85	SP3T	1-5	-
	N303B	2	75	1.6:1	Abs	85	85	SP3T	1-5	-
0.5-2	S313A	1.2	60	1.6:1	Ref	85	85	SP3T	1-5	-
	S313B	1.5	80	1.6:1	Ref	85	85	SP3T	1-5	-
	N313A	1.6	55	1.6:1	Abs	85	85	SP3T	1-5	-
	N313B	1.9	75	1.6:1	Abs	85	85	SP3T	1-5	-
2-8	S336A	1.7	60	1.7:1	Ref	85	85	SP3T	1-5	-
	S336B	1.9	80	1.7:1	Ref	85	85	SP3T	1-5	-
	N336A	1.9	55	1.7:1	Abs	85	85	SP3T	1-5	-
	N336B	2.1	70	1.7:1	Abs	85	85	SP3T	1-5	-
4-12	S347A	2.2	70	1.7:1	Ref	85	85	SP3T	1-5	-
	S347B	2.4	90	1.7:1	Ref	85	85	SP3T	1-5	-
	N347A	2.2	50	1.7:1	Abs	85	85	SP3T	1-5	-
	N347B	2.5	65	1.7:1	Abs	85	85	SP3T	1-5	-
2-18	S338A	2.7	60	2:1	Ref	85	85	SP3T	1-5	-
	S338B	3	80	2:1	Ref	85	85	SP3T	1-5	-
	N338A	2.8	45	2:1	Abs	85	85	SP3T	1-5	-
	N338B	3.2	60	2:1	Abs	85	85	SP3T	1-5	-
1-18	S328A	2.8	55	2:1	Ref	85	85	SP3T	1-5	-
	S328B	3.1	70	2:1	Ref	85	85	SP3T	1-5	-
	N328A	2.9	45	2:1	Abs	85	85	SP3T	1-5	-
	N328B	3.4	60	2:1	Abs	85	85	SP3T	1-5	-

Electrical performance of multioctave models can be optimized over narrower bandwidths, or for a particular parameter. Electrical options include: Lower insertion loss, lower VSWR, higher isolation, flat amplitude response, amplitude tracking. Mechanical/Control options include: Custom packaging, single supply operation, fast switching time, single TTL control line. Examples of custom models previously shipped are shown below. Consult factory for options.

OPTIMIZED PERFORMANCE MODELS										
4.8-7.6	126145	3	60	1.5:1	Ref	-	-	SP3T	Single 5V supply	
5.8-14.5	126144	3	60	1.6:1	Ref	-	-	Contact factory	Single 5V supply	
2-12	120608	2.2	70	1.7:1	Ref	85	85	SP3T	5V,-12V	
2-18	124081	2.7	70	2:1	Ref	-	-	SP3T	5V,-12V. 50ns switch speed	

*For reflective models, VSWR is not specified in the "OFF" state.
For absorptive models, VSWR in the "OFF" state is defined for port J2 only.

SINGLE-POLE FOUR-THROW SWITCHES

FEATURES

- Multioctave bands 0.2 to 18 GHz
- Current and TTL control
- Low loss
- High isolation
- Medium and high speed models
- Drop-in models
- Amplitude and phase tracking
- Binary decoded logic

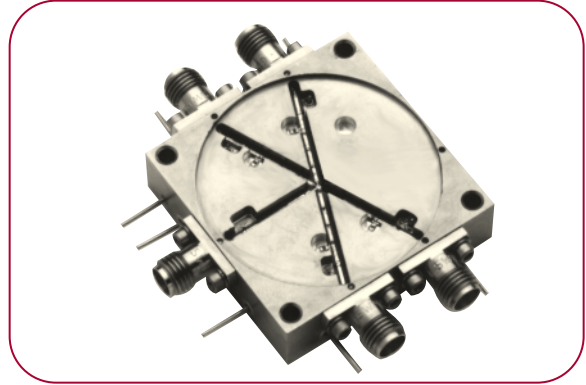

Frequency Range (GHz)	Model Number	Insertion Loss (dB, Max.)	Isolation (dB, Min.)	*VSWR (Max.)	Type (Reflective/Absorptive)	DC Power Consumption Pos. Supply (mA, Max.)	Neg. Supply (mA, Min.)	Outline	Ordering Options	Additional Features
STANDARD, MULTIOCTAVE BAND MODELS										
0.2–2	S403A	1.4	50	1.7:1	Ref	110	110	SP4T	1-5	–
	S403B	1.7	60	1.7:1	Ref	110	110	SP4T	1-5	–
	N403A	1.8	55	1.7:1	Abs	110	110	SP4T	1-5	–
	N403B	2.1	65	1.7:1	Abs	110	110	SP4T	1-5	–
0.5–2	S413A	1.3	55	1.7:1	Ref	110	110	SP4T	1-5	–
	S413B	1.6	65	1.7:1	Ref	110	110	SP4T	1-5	–
	N413A	1.7	55	1.7:1	Abs	110	110	SP4T	1-5	–
	N413B	2	65	1.7:1	Abs	110	110	SP4T	1-5	–
2–8	S436A	1.8	55	1.8:1	Ref	110	110	SP4T	1-5	–
	S436B	2	65	1.8:1	Ref	110	110	SP4T	1-5	–
	N436A	2	55	1.8:1	Abs	110	110	SP4T	1-5	–
	N436B	2.3	65	1.8:1	Abs	110	110	SP4T	1-5	–
4–12	S447A	2.4	55	1.8:1	Ref	110	110	SP4T	1-5	–
	S447B	2.6	65	1.8:1	Ref	110	110	SP4T	1-5	–
	N447A	2.4	50	1.8:1	Abs	110	110	SP4T	1-5	–
	N447B	2.7	65	1.8:1	Abs	110	110	SP4T	1-5	–
2–18	S438A	2.8	50	2:1	Ref	110	110	SP4T	1-5	–
	S438B	3.1	60	2:1	Ref	110	110	SP4T	1-5	–
	N438A	3	45	2:1	Abs	110	110	SP4T	1-5	–
	N438B	3.4	60	2:1	Abs	110	110	SP4T	1-5	–
1–18	S428A	3	50	2:1	Ref	110	110	SP4T	1-5	–
	S428B	3.3	60	2:1	Ref	110	110	SP4T	1-5	–
	N428A	3.2	45	2:1	Abs	110	110	SP4T	1-5	–
	N428B	3.6	60	2:1	Abs	110	110	SP4T	1-5	–

Electrical performance of multioctave models can be optimized over narrower bandwidths, or for a particular parameter. Electrical options include: Lower insertion loss, lower VSWR, higher isolation, flat amplitude response, amplitude tracking. Mechanical/Control options include: Custom packaging, single supply operation, fast switching time, single TTL control line. Examples of custom models previously shipped are shown below. Consult factory for options.

OPTIMIZED PERFORMANCE MODELS										
0.5–4	125482	1.6	65	2:1	Ref	110	110	SP4T	5V, -15V	
5–6	127935	2.2	60	1.7:1	Abs	35	–	Contact factory	Single 5V supply	
5–6	126940	1.4	55	1.5:1	Abs	110	110	SP4T	5V, -15V	
9–11	127087	2.6	70	1.5:1	Abs	35	–	Contact factory	Single 5V supply	
3.4–12.8	126142	3	60	1.5:1	Ref	–	–	Contact factory	Single 5V supply	

*For reflective models, VSWR is not specified in the “OFF” state.
For absorptive models, VSWR in the “OFF” state is defined for port J2 only.

SINGLE-POLE FIVE-THROW SWITCHES

FEATURES

- Multioctave bands 0.2 to 18 GHz
- Current and TTL control
- Low loss
- High isolation
- Medium and high speed models
- Drop-in models
- Amplitude and phase tracking
- Binary decoded logic

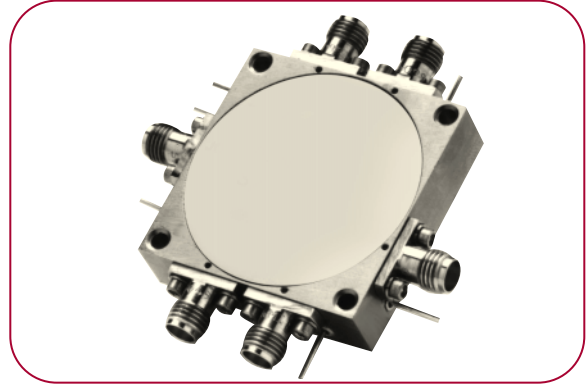

Frequency Range (GHz)	Model Number	Insertion Loss (dB, Max.)	Isolation (dB, Min.)	*VSWR (Max.)	Type (Reflective/Absorptive)	DC Power Consumption Pos. Supply (mA, Max.)	DC Power Consumption Neg. Supply (mA, Min.)	Outline	Ordering Options	Additional Features
STANDARD, MULTIOCTAVE BAND MODELS										
0.2–2	S503A	1.5	50	1.7:1	Ref	135	135	SP5T	1-5	–
	S503B	1.8	60	1.7:1	Ref	135	135	SP5T	1-5	–
	N503A	1.9	55	1.7:1	Abs	135	135	SP5T	1-5	–
	N503B	2.2	65	1.7:1	Abs	135	135	SP5T	1-5	–
0.5–2	S513A	1.4	55	1.7:1	Ref	135	135	SP5T	1-5	–
	S513B	1.7	65	1.7:1	Ref	135	135	SP5T	1-5	–
	N513A	1.8	55	1.7:1	Abs	135	135	SP5T	1-5	–
	N513B	2.1	65	1.7:1	Abs	135	135	SP5T	1-5	–
2–8	S536A	1.9	55	1.8:1	Ref	135	135	SP5T	1-5	–
	S536B	2.1	65	1.8:1	Ref	135	135	SP5T	1-5	–
	N536A	2.1	55	1.8:1	Abs	135	135	SP5T	1-5	–
	N536B	2.4	65	1.8:1	Abs	135	135	SP5T	1-5	–
4–12	S547A	2.6	55	1.8:1	Ref	135	135	SP5T	1-5	–
	S547B	2.8	65	1.8:1	Ref	135	135	SP5T	1-5	–
	N547A	2.6	50	1.8:1	Abs	135	135	SP5T	1-5	–
	N547B	2.9	65	1.8:1	Abs	135	135	SP5T	1-5	–
2–18	S538A	3	50	2:1	Ref	135	135	SP5T	1-5	–
	S538B	3.3	60	2:1	Ref	135	135	SP5T	1-5	–
	N538A	3.2	45	2:1	Abs	135	135	SP5T	1-5	–
	N538B	3.6	60	2:1	Abs	135	135	SP5T	1-5	–
1–18	S528A	3.2	50	2:1	Ref	135	135	SP5T	1-5	–
	S528B	3.5	60	2:1	Ref	135	135	SP5T	1-5	–
	N528A	3.4	45	2:1	Abs	135	135	SP5T	1-5	–
	N528B	3.8	60	2:1	Abs	135	135	SP5T	1-5	–

Electrical performance of multioctave models can be optimized over narrower bandwidths, or for a particular parameter. Electrical options include: Lower insertion loss, lower VSWR, higher isolation, flat amplitude response, amplitude tracking. Mechanical/Control options include: Custom packaging, single supply operation, fast switching time, single TTL control line. Consult factory for options.

*For reflective models, VSWR is not specified in the “OFF” state.
For absorptive models, VSWR in the “OFF” state is defined for port J2 only.

SINGLE-POLE SIX-THROW SWITCHES

FEATURES

- Multioctave bands 0.2 to 18 GHz
- Current and TTL control
- Low loss
- High isolation
- Medium and high speed models
- Drop-in models
- Amplitude and phase tracking
- Binary decoded logic

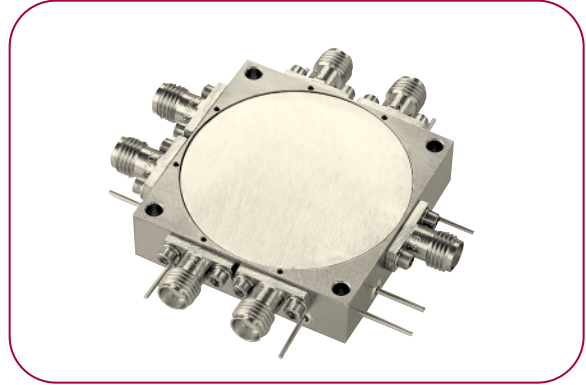

Frequency Range (GHz)	Model Number	Insertion Loss (dB, Max.)	Isolation (dB, Min.)	*VSWR (Max.)	Type (Reflective/Absorptive)	DC Power Consumption		Outline	Ordering Options	Additional Features
						Pos. Supply (mA, Max.)	Neg. Supply (mA, Min.)			
STANDARD, MULTIOCTAVE BAND MODELS										
0.2-2	S603A	1.6	50	1.7:1	Ref	160	160	SP6T	1-5	-
	S603B	1.9	60	1.7:1	Ref	160	160	SP6T	1-5	-
	N603A	2	55	1.7:1	Abs	160	160	SP6T	1-5	-
	N603B	2.3	65	1.7:1	Abs	160	160	SP6T	1-5	-
0.5-2	S613A	1.5	55	1.7:1	Ref	160	160	SP6T	1-5	-
	S613B	1.8	65	1.7:1	Ref	160	160	SP6T	1-5	-
	N613A	1.9	55	1.7:1	Abs	160	160	SP6T	1-5	-
	N613B	2.2	65	1.7:1	Abs	160	160	SP6T	1-5	-
2-8	S636A	2	55	1.8:1	Ref	160	160	SP6T	1-5	-
	S636B	2.2	65	1.8:1	Ref	160	160	SP6T	1-5	-
	N636A	2.2	55	1.8:1	Abs	160	160	SP6T	1-5	-
	N636B	2.5	65	1.8:1	Abs	160	160	SP6T	1-5	-
4-12	S647A	2.7	55	1.8:1	Ref	160	160	SP6T	1-5	-
	S647B	2.9	65	1.8:1	Ref	160	160	SP6T	1-5	-
	N647A	2.8	50	1.8:1	Abs	160	160	SP6T	1-5	-
	N647B	3.1	65	1.8:1	Abs	160	160	SP6T	1-5	-
2-18	S638A	3.2	50	2:1	Ref	160	160	SP6T	1-5	-
	S638B	3.5	60	2:1	Ref	160	160	SP6T	1-5	-
	N638A	3.4	45	2:1	Abs	160	160	SP6T	1-5	-
	N638B	3.8	60	2:1	Abs	160	160	SP6T	1-5	-
1-18	S628A	3.4	50	2:1	Ref	160	160	SP6T	1-5	-
	S628B	3.7	60	2:1	Ref	160	160	SP6T	1-5	-
	N628A	3.6	45	2:1	Abs	160	160	SP6T	1-5	-
	N628B	4	60	2:1	Abs	160	160	SP6T	1-5	-

Electrical performance of multioctave models can be optimized over narrower bandwidths, or for a particular parameter. Electrical options include: Lower insertion loss, lower VSWR, higher isolation, flat amplitude response, amplitude tracking. Mechanical/Control options include: Custom packaging, single supply operation, fast switching time, single TTL control line. Examples of custom models previously shipped are shown below. Consult factory for options.

OPTIMIZED PERFORMANCE MODELS										
0.6-2.5	122516	2.5	65	1.7:1	Abs	160	160	SP6T	5V,-5V	
9-11	126153	2.5	40	1.5:1	Ref	25	-	Contact factory	Single 5V supply	

*For reflective models, VSWR is not specified in the "OFF" state.
For absorptive models, VSWR in the "OFF" state is defined for port J2 only.

SINGLE-POLE SEVEN-THROW SWITCHES

FEATURES

- Multioctave bands 0.2 to 18 GHz
- Current and TTL control
- Low loss
- High isolation
- Medium and high speed models
- Drop-in models
- Amplitude and phase tracking
- Binary decoded logic

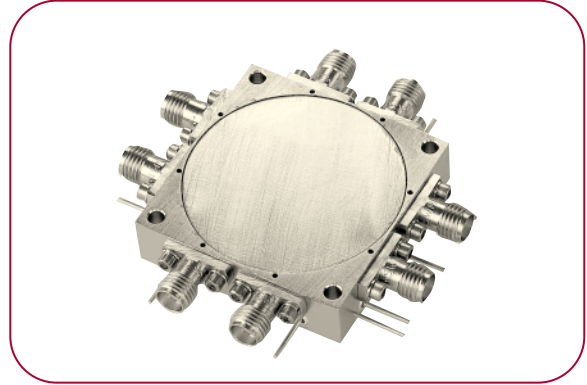

Frequency Range (GHz)	Model Number	Insertion Loss (dB, Max.)	Isolation (dB, Min.)	*VSWR (Max.)	Type (Reflective/Absorptive)	DC Power Consumption		Outline	Ordering Options	Additional Features
						Pos. Supply (mA, Max.)	Neg. Supply (mA, Min.)			
STANDARD, MULTIOCTAVE BAND MODELS										
0.2–2	S703A	1.7	50	1.7:1	Ref	185	185	SP7T	1-5	–
	S703B	2	60	1.7:1	Ref	185	185	SP7T	1-5	–
	N703A	2.1	55	1.7:1	Abs	185	185	SP7T	1-5	–
	N703B	2.4	65	1.7:1	Abs	185	185	SP7T	1-5	–
0.5–2	S713A	1.6	55	1.7:1	Ref	185	185	SP7T	1-5	–
	S713B	1.9	65	1.7:1	Ref	185	185	SP7T	1-5	–
	N713A	2	55	1.7:1	Abs	185	185	SP7T	1-5	–
	N713B	2.3	65	1.7:1	Abs	185	185	SP7T	1-5	–
2–8	S736A	2.1	55	1.8:1	Ref	185	185	SP7T	1-5	–
	S736B	2.3	65	1.8:1	Ref	185	185	SP7T	1-5	–
	N736A	2.3	55	1.8:1	Abs	185	185	SP7T	1-5	–
	N736B	2.6	65	1.8:1	Abs	185	185	SP7T	1-5	–
4–12	S747A	2.9	55	1.8:1	Ref	185	185	SP7T	1-5	–
	S747B	3.1	65	1.8:1	Ref	185	185	SP7T	1-5	–
	N747A	3	50	1.8:1	Abs	185	185	SP7T	1-5	–
	N747B	3.2	65	1.8:1	Abs	185	185	SP7T	1-5	–
2–18	S738A	3.4	50	2:1	Ref	185	185	SP7T	1-5	–
	S738B	3.7	60	2:1	Ref	185	185	SP7T	1-5	–
	N738A	3.6	45	2:1	Abs	185	185	SP7T	1-5	–
	N738B	4	60	2:1	Abs	185	185	SP7T	1-5	–
1–18	S728A	3.6	50	2:1	Ref	185	185	SP7T	1-5	–
	S728B	3.9	60	2:1	Ref	185	185	SP7T	1-5	–
	N728A	3.8	45	2:1	Abs	185	185	SP7T	1-5	–
	N728B	4.2	60	2:1	Abs	185	185	SP7T	1-5	–

Electrical performance of multioctave models can be optimized over narrower bandwidths, or for a particular parameter. Electrical options include: Lower insertion loss, lower VSWR, higher isolation, flat amplitude response, amplitude tracking. Mechanical/Control options include: Custom packaging, single supply operation, fast switching time, single TTL control line. Examples of custom models previously shipped are shown below. Consult factory for options.

OPTIMIZED PERFORMANCE MODELS

1–1.5	127069	1.5	60	1.6:1	Abs	–	–	SP7T	2-3	15V, -15V 1ns switch speed
-------	--------	-----	----	-------	-----	---	---	------	-----	----------------------------

*For reflective models, VSWR is not specified in the “OFF” state.
For absorptive models, VSWR in the “OFF” state is defined for port J2 only.

SWITCH OUTLINE DRAWINGS

SP2T

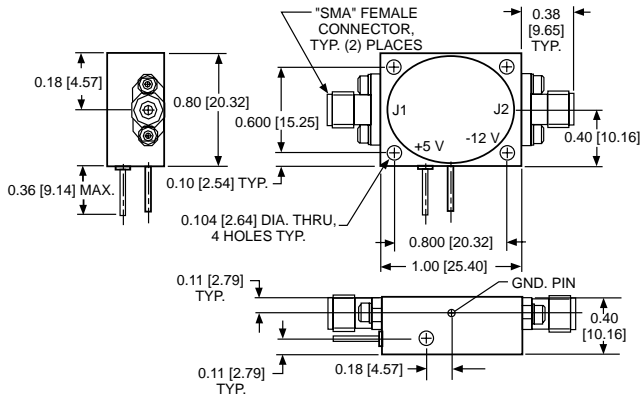

SP2T

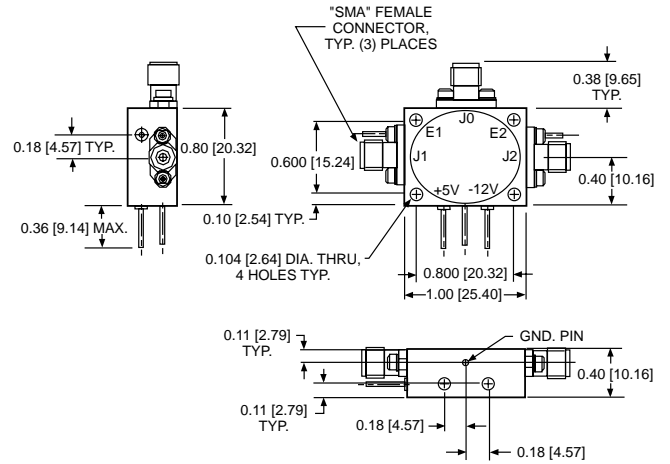

SP3T

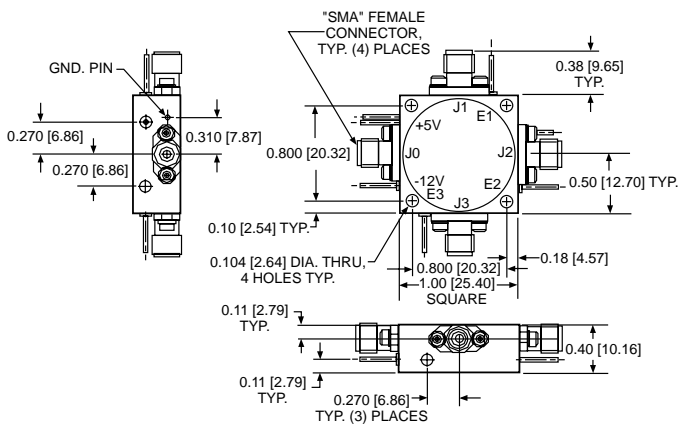

SP4T

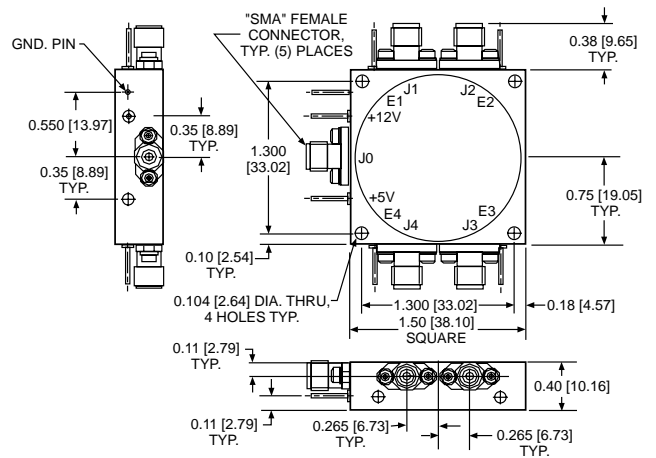

SP5T

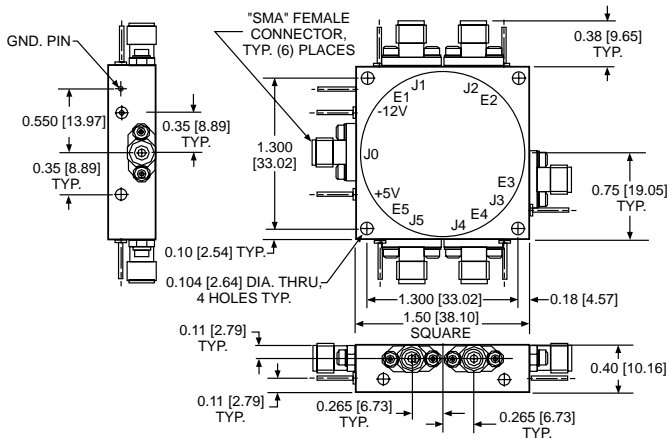

SP6T

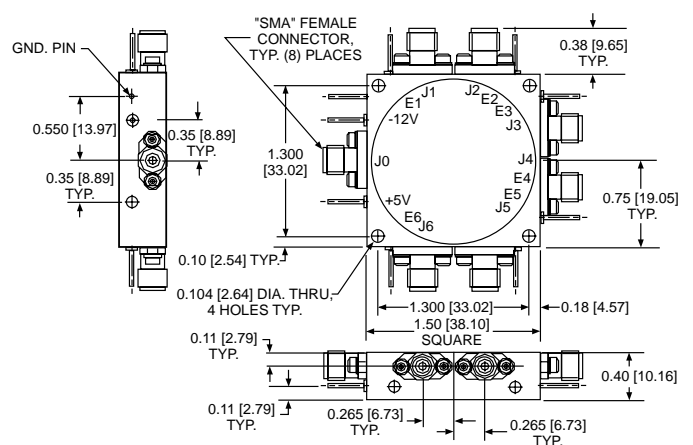

GENERAL NOTES:

- Dimensions shown in brackets [] are in millimeters.
- Unless specified, all connectors are type SMA female field replaceable. SMA male also available, see ordering options.
- Tolerance as follows:
 .xx = ± 0.01 [xx = ± 0.25]
 .xxx = ± 0.005 [xxx = ± 0.13]

SWITCH OUTLINE DRAWINGS (CONT.)

SP7T

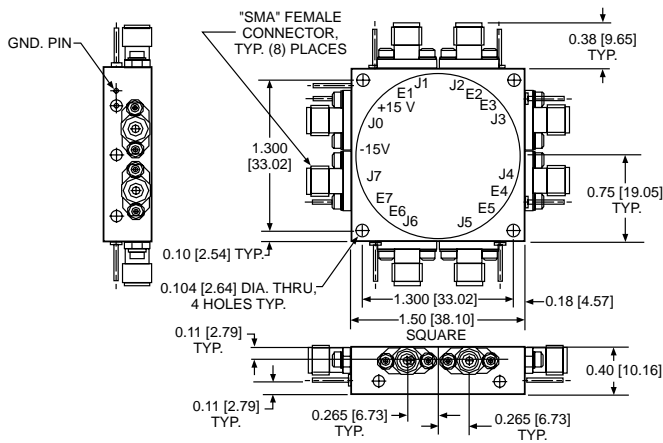

GENERAL NOTES:

1. Dimensions shown in brackets [] are in millimeters.
2. Unless specified, all connectors are type SMA female field replaceable. SMA male also available, see ordering options.
3. Tolerance as follows:
 .xx = ± 0.01 [.xx = ± 0.25]
 .xxx = ± 0.005 [xxx = ± 0.13]

ORDERING INFORMATION

To order a standard switch with specific parameters please include the following:

	<u>S236B</u>	<u>D</u>	<u>F</u>	<u>O</u>
Model Number	Specify from tables on previous pages.			
Impedance Control Option	Current control, each throw: -2V @ 15 mA typ. (insertion loss) 2V @ 20 mA typ. (isolation) Blank TTL driver, inverting logic "O" = Isolation, "I" = Insertion loss D TTL driver, noninverting logic "I" = Isolation, "O" = Insertion loss N			
Rise/Fall Time, ns	Medium: 300ns maximum M Fast: 20 ns, SP2T – SP7T F Ultrafast: 3 ns maximum Available in models S113, S136, S147 and S138 only U			
Power Supply	5V, -12V 0 5V, -5V 1 5V, -15V 2			

The above illustrated switch Part Number *S236B-D-F-O* is based on the following parameters:

- 2–8 GHz Single-Pole Double-Throw Switch
- Isolation 80 dB
- "OFF" state Reflective
- Impedance control TTL, inverting logic
- Rise/fall time 20 ns maximum
- Power supply 5V, -12V

ORDERING INFORMATION FOR RF CONNECTORS

Unless otherwise specified on the purchase order, units will be shipped with field replaceable SMA female connectors on the input and outputs. If male connectors are desired on any ports, specify on the purchase order.



TEL: (631) 439-9137
 FAX: (631) 436-9219
 E-MAIL: jpierro@miteq.com

PIN SWITCHES

DATE _____

COMPANY _____

ADDRESS _____

CONTACT _____

TEL. _____

FAX _____

E-MAIL _____

For additional technical, price and delivery information, please copy, complete and mail or fax this form to (631) 436-9219, or call John Pierro at (631) 439-9137.

SPECIFICATION PARAMETER	REQUIREMENT 1	REQUIREMENT 2	REQUIREMENT 3
Frequency range (GHz)			
Type (i.e., SP6T)			
Insertion loss (dB, maximum)			
Isolation (dB, minimum)			
VSWR (maximum)			
Type (reflective/absorptive)			
DC power (\pm V)			
Current consumption (\pm V, mA)			
Video leakage (dBm)			
Switching speed (ns)			
Connectors			
Operating temperature			
Quantity			

Special requirements, such as special testing/screening, or specific operating environment may be listed below:

PLEASE SEND ADDITIONAL INFORMATION ON THE FOLLOWING MITEQ PRODUCTS:

- | | |
|--|--|
| <input type="checkbox"/> Amplifiers | <input type="checkbox"/> Passive Power Components |
| <input type="checkbox"/> Mixers | <input type="checkbox"/> IF Signal Processing Components |
| <input type="checkbox"/> Multipliers | <input type="checkbox"/> Integrated Assemblies |
| <input type="checkbox"/> Frequency Sources | <input type="checkbox"/> SATCOM Products |



100 Davids Drive, Hauppauge, NY 11788
 TEL.: (631) 436-7400 • FAX: (631) 436-9219/436-7430
 www.miteq.com