

PIB Instructions

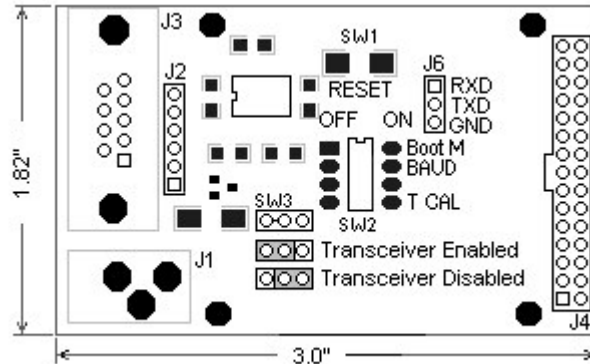

Warning: Do not apply power while module is being connected or disconnected. Doing so may damage the display and void warranty.

1. Set Sw2 to normal settings.
See Dip Switch Settings for more information.



2. Install Module, connect data cable, and apply power.

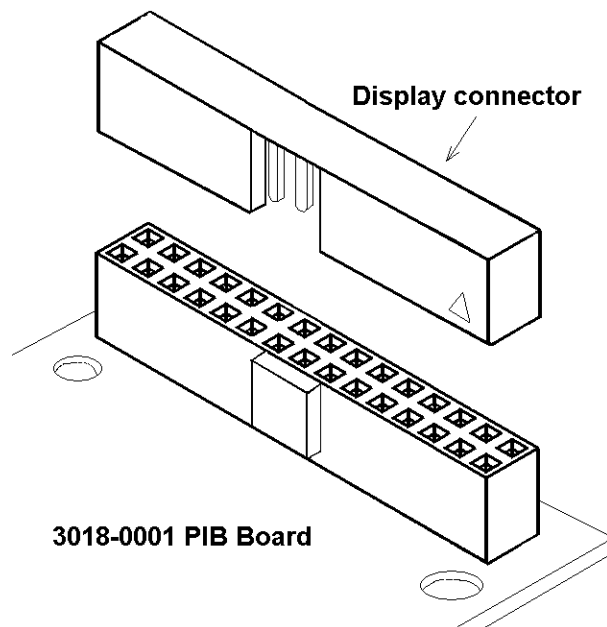

Power Supply

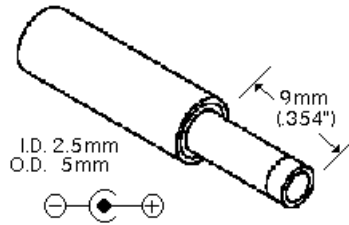

CAUTION: Do not reverse the polarity on the power input. Doing so will permanently damage the module and invalidate your warranty.

**Figure 2. Power Input Power is applied to the 2.5mm connector.
Power requirement 5 +/-10% VDC @250mA**

RS-232 DB9 J3 Specs

Pin #	Description
1	N/C
2	TX (Amulet GUI module transmits data on Pin 2 while the PC receives data on Pin 2)
3	RX (Amulet GUI module receives data on Pin 3 while the PC transmits data on Pin 3)
4	Pin 4 to 6 – Jumpered
5	Ground
6	Pin 4 to 6 - Jumpered
7	Pin 7 to 8 - Jumpered
8	Pin 7 to 8 – Jumpered
9	N/C

The serial parameters for communications between the Amulet client and the server are, as follows:

Baud Rate: 9600, 19200, 57600, or 115200bps

Parity: None

Data Bits: 8

Stop Bits: 1

DIP Switch Settings

The Easy GUI controller board can be powered up in different modes via the settings of the DIP switch (SW2). Some of the power up modes include: programming mode, run mode, RAM test mode, and touch panel mode.



Figure 5. DIP Switch Settings

Boot Mode (Switch 1) -- This switch is monitored during a reboot to determine the operational mode of the controller board; ON is the normal mode and OFF is the FLASH program mode. The only time you should have to set Switch 1 to OFF (program mode) is when the project you compiled locks up the Amulet OS to the point where it won't accept the wake up message or if the Amulet OS has been corrupted and you need to [reload the OS](#).

Flash Mode Baud Rate (Switch 2) -- This switch sets the baud rate used during a Flash Reprogram. The ON position sets the hardware to 19,200 baud; OFF sets the hardware to 115,200 baud. This setting must match the baud rate selected in the Amulet Compiler software.

Touch panel Mode (Switch 4) -- This switch should remain ON during normal operation. Turn this switch OFF and then reboot the controller board to begin a touch panel calibration. The controller will display a series of three calibration targets. Use a stylus to touch the center of each target. If necessary, the controller will repeat the calibration. When calibration is complete, the controller will return to normal operation. The switch must be returned to the normal mode (ON) before the next reboot to continue normal operation.

Pin #	Signal	Description
1	GND	Ground
2	Boot M	Boot Mode Float = Program Mode, GND = Normal Mode
3	TXD	T1OUT from RS232 Transceiver
4	RXD	R1IN from RS232 Transceiver
5	N/C	
6	5V	Voltage In 5V +/- 10% @ 250mA

J2 connector

Pin #	Signal	Description
1	R1OUT	RXD Input to RS232 Transceiver R1OUT (JRXD)
2	T1IN	TXD Input to RS232 Transceiver T1IN (JTXD)
3	GND	Ground

J6 connector

SW3

If it is desired to connect directly to the Amulet UART using J6 Then the Transceiver must be disabled using SW3. Cut the trace between pin1 and pin2 on SW3. Install a three pin header in SW3 and short pins 2 and 3.