



## 2.5V, 3.3V LVCMOS 1:18 Clock Fanout Buffer AK8180E

### Features

- 18 LVCMOS outputs enable to drive up to 36 clock lines
- LVCMOS/LVTTL input
- 2.5V or 3.3V power supply
- Clock output frequency up to 200MHz
- Output-to-output skew: 85ps (typical)
- Output enable control
- Operating Temperature Range: -40 to +85°C
- Package: 32-pin LQFP (Pb free)
- Pin compatible with CY29942, MPC942C

### Description

The AK8180E is a member of AKM's LVCMOS clock fanout buffer family designed for telecom, networking and computer applications, requiring a range of clocks with high performance and low skew. The AK8180E distributes 18 buffered clocks up to 200MHz. The 18 outputs can drive terminated 50  $\Omega$  clock lines. AK8180E are derived from AKM's long-term-experienced clock device technology, and enable clock output to perform low skew and to operate with very low current consumption. The AK8180E is available in a 7mm x 7mm 32-pin LQFP package.

### Block Diagram

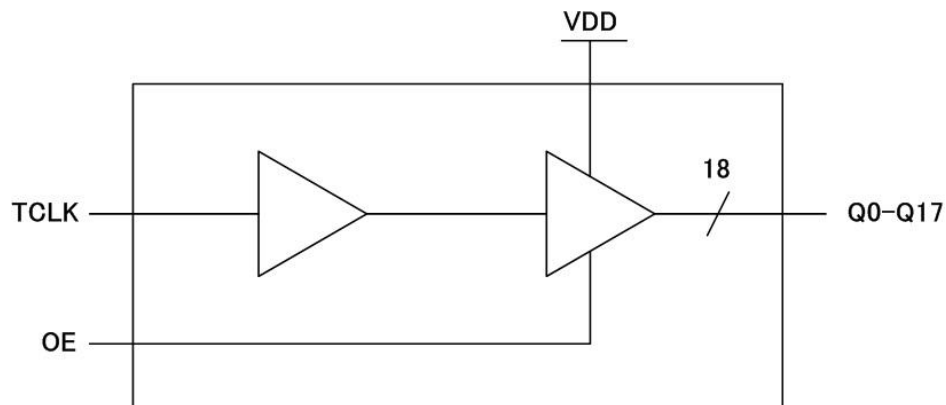

Pin Descriptions

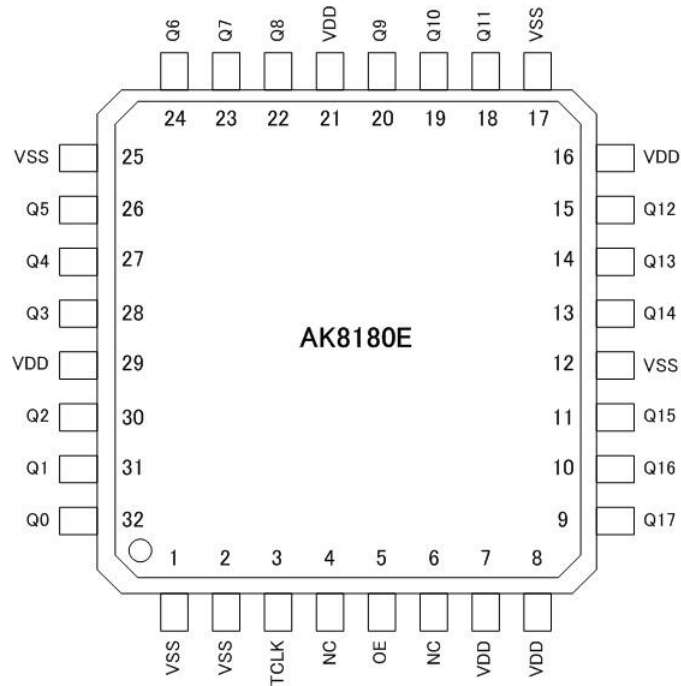

Package: 32-Pin LQFP(Top View)

Pin No.	Pin Name	Pin Type	pullup /down	Description
1	VSS	PWR		Ground
2	VSS	PWR		Ground
3	TCLK	IN	PD	Clock Input (LVCMOS/LVTTL)
4	NC	--	PD	It should be connected to VSS or opened
5	OE	IN	PU	Clock Output Enable High (open): clock outputs follow clock input Low: clock outputs become high impedance
6	NC	--	PD	It should be connected to VSS or opened
7	VDD	PWR		Power Supply
8	VDD	PWR		Power Supply
9	Q17	OUT		Clock Output
10	Q16	OUT		Clock Output
11	Q15	OUT		Clock Output
12	VSS	PWR		Ground
13	Q14	OUT		Clock Output
14	Q13	OUT		Clock Output
15	Q12	OUT		Clock Output
16	VDD	PWR		Power Supply

(continue on next page)

Pin No.	Pin Name	Pin Type	Pullup /down	Description
17	VSS	PWR		Ground
18	Q11	OUT		Clock Output
19	Q10	OUT		Clock Output
20	Q9	OUT		Clock Output
21	VDD	PWR		Power Supply
22	Q8	OUT		Clock Output
23	Q7	OUT		Clock Output
24	Q6	OUT		Clock Output
25	VSS	PWR		Ground
26	Q5	OUT		Clock Output
27	Q4	OUT		Clock Output
28	Q3	OUT		Clock Output
29	VDD	PWR		Power Supply
30	Q2	OUT		Clock Output
31	Q1	OUT		Clock Output
32	Q0	OUT		Clock Output

PWR: Power pin, IN: Input pin, OUT: Output pin

PU: Pull up, PD: Pull down

### Ordering Information

Part Number	Marking	Shipping Packaging	Package	Temperature Range
AK8180E	AK8180E	Tape and Reel	32-pin LQFP	-40 to 85 °C

## Absolute Maximum Rating

Over operating free-air temperature range unless otherwise noted <sup>(1)</sup>

Items	Symbol	Ratings	Unit
Supply voltage	VDD	-0.3 to 4.6	V
Ground level	VSS	0	V
Input voltage	V <sub>in</sub>	VSS-0.5 to VDD+0.5	V
Input current (any pins except supplies)	I <sub>IN</sub>	±10	mA
Storage temperature	T <sub>stg</sub>	-55 to 150	°C

Note

(1) Stress beyond those listed under “Absolute Maximum Ratings” may cause permanent damage to the device. These are stress ratings only. Functional operation of the device at these or any other conditions beyond those indicated under “Recommended Operating Conditions” is not implied. Exposure to absolute-maximum-rating conditions for extended periods may affect device reliability. Electrical parameters are guaranteed only over the recommended operating temperature range.



### ESD Sensitive Device

This device is manufactured on a CMOS process, therefore, generically susceptible to damage by excessive static voltage. Failure to observe proper handling and installation procedures can cause damage. AKM recommends that this device is handled with appropriate precautions.

## Recommended Operation Conditions

Parameter	Symbol	Conditions	Min	Typ	Max	Unit
Operating temperature	T <sub>a</sub>		-40		85	°C
Supply voltage <sup>(1)</sup>	VDD	VDD±5%	2.375	2.5	2.625	V
			3.135	3.3	3.465	

(1) Power of 2.5V or 3.3V requires to be supplied from a single source. A decoupling capacitor of 0.1μF for power supply line should be located close to each VDD pin.

## General Specification

Parameter	Symbol	Conditions	Min	Typ	Max	Unit
Output Termination Voltage	V <sub>TT</sub>			VDD/2		V
Input Capacitance	C <sub>IN</sub>			4.0		pF
Input Pullup Resistor	R <sub>PU</sub>			51		kΩ
Input Pulldown Resistor	R <sub>PD</sub>			51		kΩ

## DC Characteristics

VDD = 3.3V±5% or 2.5V±5%, Ta: -40 to +85°C, unless otherwise noted

Parameter	Symbol	Conditions	MIN	TYP	MAX	Unit
Input High Voltage	V <sub>IH</sub>	Pin: TCLK, OE	2.0		VDD+0.3	V
Input Low Voltage	V <sub>IL</sub>	Pin: TCLK, OE	VSS-0.3		0.8	V
Input Current <sup>(1), (2)</sup>	I <sub>IN</sub>	Pin: TCLK, OE	-200		200	μA
Output High Voltage	V <sub>OH</sub>	I <sub>OH</sub> = -20mA <sup>(2), (3)</sup> , VDD=3.3V I <sub>OH</sub> = -16mA <sup>(2), (3)</sup> , VDD=2.5V	2.4 2.0			V
Output Low Voltage	V <sub>OL</sub>	I <sub>OL</sub> = +20mA <sup>(2), (3)</sup>			0.5	V
Quiescent Supply Current	I <sub>DDQ</sub>	OE=VSS, TCLK=H/L		0.1	7	mA
Dynamic Supply Current	I <sub>DD</sub>	VDD=3.3V, Outputs at 150MHz C <sub>L</sub> =15pF		285		mA
		VDD=3.3V, Outputs at 200MHz C <sub>L</sub> =15pF		335		mA
		VDD=2.5V, Outputs at 150MHz C <sub>L</sub> =15pF		200		mA
		VDD=2.5V, Outputs at 200MHz C <sub>L</sub> =15pF		240		mA
Output Impedance	Z <sub>OUT</sub>		7		22	Ω

- (1) Inputs have pull-up / pull down resistors that effect input current.  
 (2) Polarity (-): Outgoing current from device.  
 Polarity (+): Incoming current to device.  
 (3) Driving series or parallel terminated 50Ω (or 50Ω to VTT) transmission lines.

## AC Characteristics <3.3V>

VDD = 3.3V±5%, Ta: -40 to +85°C, unless otherwise noted

Parameter	Symbol	Conditions	MIN	TYP	MAX	Unit
Input Frequency	$f_{IN}$				200	MHz
Propagation Delay	$t_{pd}$	TCLK to any Q <sup>(1), (2)</sup>	0.9		2.5	ns
Output Duty Cycle	DC <sub>OUT</sub>	Measured at VTT <sup>(1), (2), (3)</sup>	45		55	%
Output-to-Output Skew	$t_{skpp}$	<sup>(1), (2),</sup>		85	200	ps
Part-to-Part Skew <sup>(4)</sup>	$t_{skD1}$				1.6	ns
Part-to-Part Skew <sup>(5)</sup>	$t_{skD2}$				600	ps
Output Rise/Fall Time	$t_r, t_f$	0.8V to 2.0V <sup>(1), (2)</sup>	0.08		0.6	ns

- (1) Outputs driving 50Ω transmission lines.
- (2) See Figure 1.
- (3) 50% input duty cycle.
- (4) Across temperature and voltage ranges, includes output skew.
- (5) For a specific temperature and voltage, includes output skew.

## AC Characteristics <2.5V>

VDD = 2.5V±5%, Ta: -40 to +85°C, unless otherwise noted

Parameter	Symbol	Conditions	MIN	TYP	MAX	Unit
Input Frequency	$f_{IN}$				200	MHz
Propagation Delay	$t_{pd}$	TCLK to any Q <sup>(1), (2)</sup>	1.0		3.0	ns
Output Duty Cycle	DC <sub>OUT</sub>	Measured at VTT <sup>(1), (2), (3)</sup>	45		55	%
Output-to-Output Skew	$t_{skpp}$	<sup>(1), (2),</sup>		85	200	ps
Part-to-Part Skew <sup>(4)</sup>	$t_{skD1}$				2.0	ns
Part-to-Part Skew <sup>(5)</sup>	$t_{skD2}$				600	ps
Output Rise/Fall Time	$t_r, t_f$	0.5V to 1.8V <sup>(1), (2)</sup>	0.15		1.0	ns

- (1) Outputs driving 50Ω transmission lines.
- (2) See Figure 1.
- (3) 50% input duty cycle.
- (4) Across temperature and voltage ranges, includes output skew.
- (5) For a specific temperature and voltage, includes output skew.

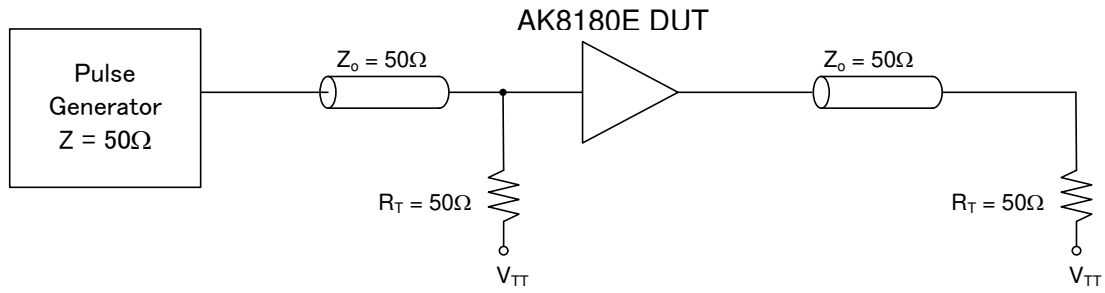

Figure 1. LVC MOS\_CLK Test Reference

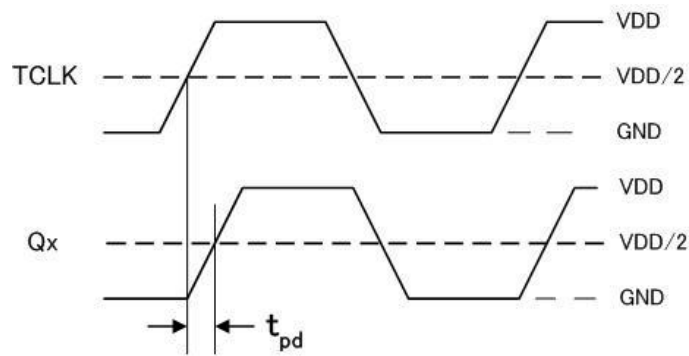

Figure 2. LVC MOS Propagation Delay ( $t_{pd}$ ) Test Reference

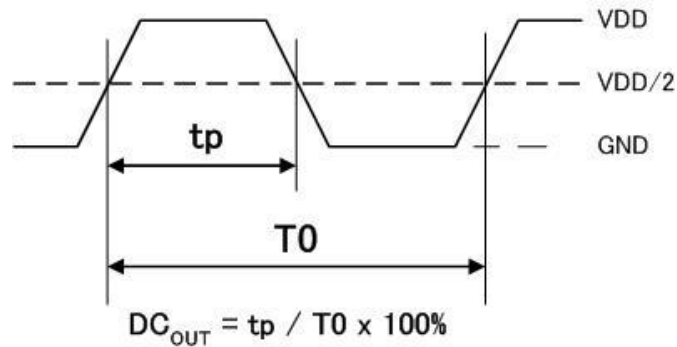

Figure 3. Output Duty Cycle ( $DC_{OUT}$ )

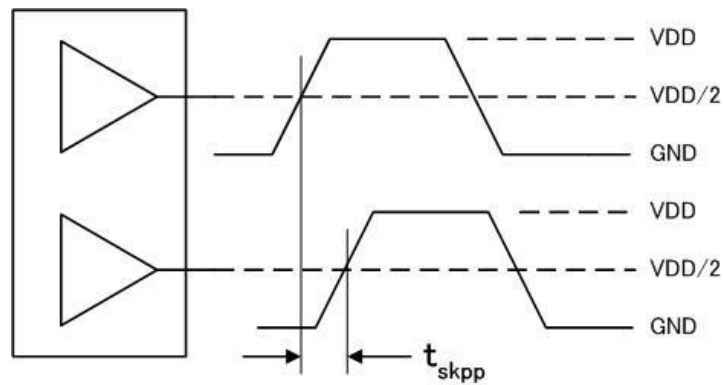

Figure 4. Output-to-Output Skew ( $t_{skpp}$ )

## Function Table

The following table shows the inputs/outputs clock state configured through the control pins.

**Table 1: Control Input Function Table**

Input	Output
<b>OE</b>	<b>Q0:Q17</b>
L	Disabled (high impedance)
H	Enabled



## Package Information

- Mechanical data : 32-lead LQFP

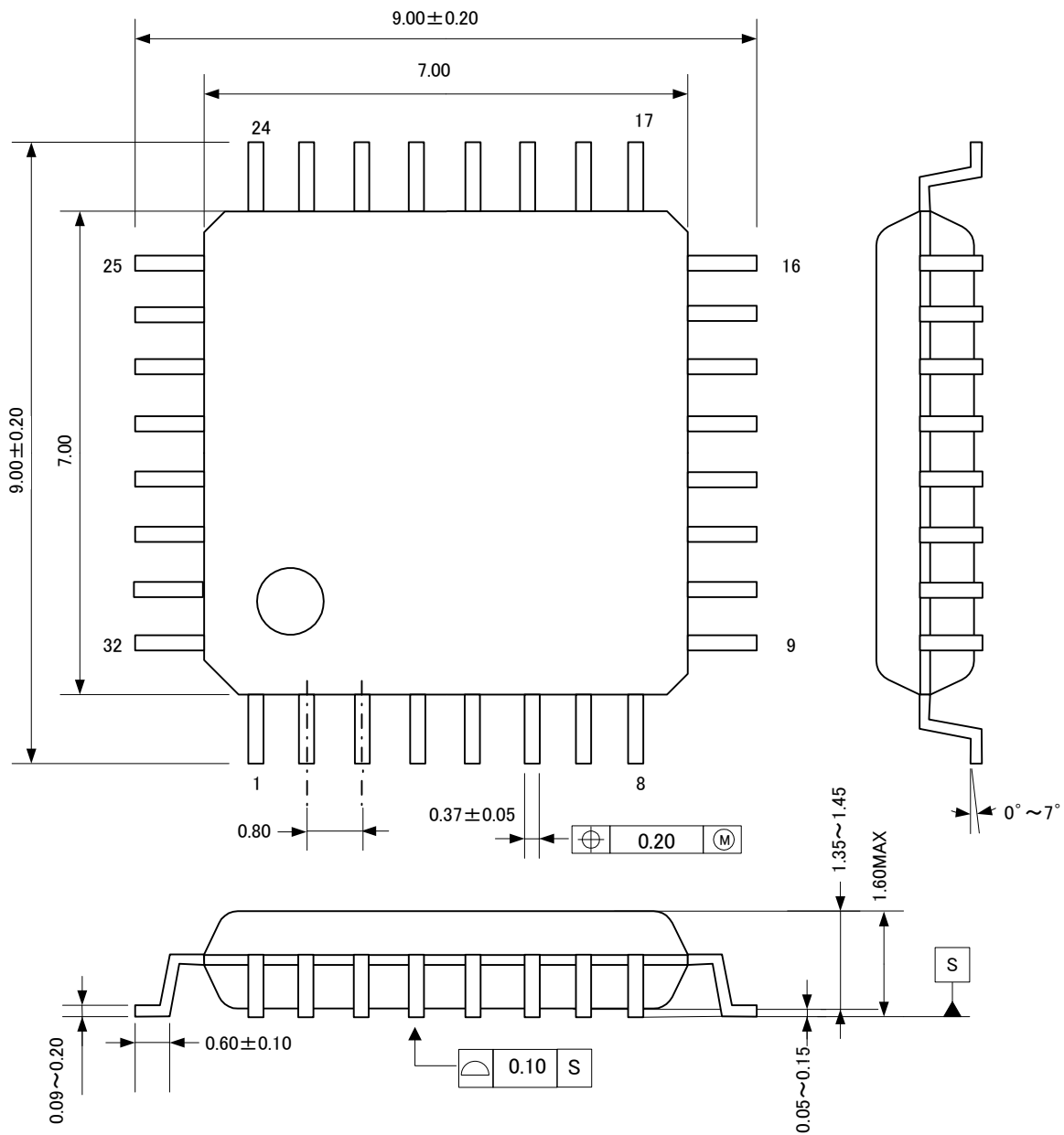

• **Marking**

- a: #1 Pin Index
- b: Part number
- c: Date code (7 digits)

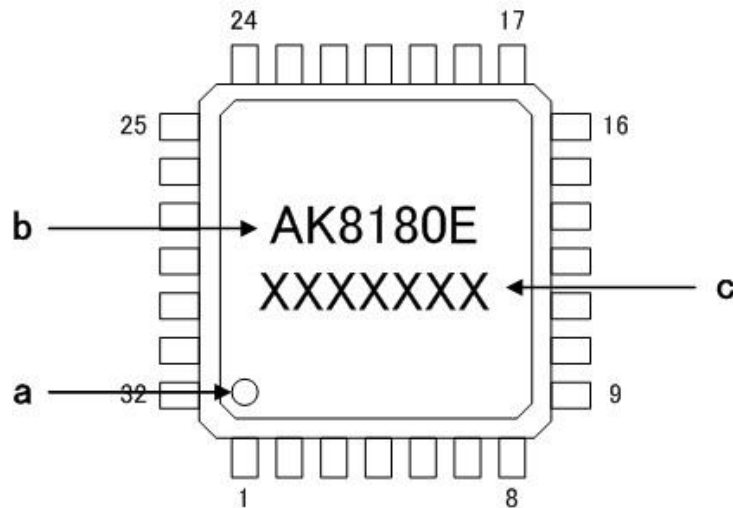

(1) **AKM** is the brand name of AKM's IC's.

**AKM** and the logo -  - are the brand of AKM's IC's and identify that AKM continues to offer the best choice for high performance mixed-signal solution under this brand.

• **RoHS Compliance**



All integrated circuits from Asahi Kasei Microdevices Corporation (AKM) assembled in "lead-free" packages\* are fully compliant with RoHS.

(\*) RoHS compliant products from AKM are identified with "Pb free" letter indication on product label posted on the anti-shield bag and boxes.

**IMPORTANT NOTICE**

- These products and their specifications are subject to change without notice. When you consider any use or application of these products, please make inquiries the sales office of Asahi Kasei Microdevices Corporation (AKM) or authorized distributors as to current status of the products.
- Descriptions of external circuits, application circuits, software and other related information contained in this document are provided only to illustrate the operation and application examples of the semiconductor products. You are fully responsible for the incorporation of these external circuits, application circuits, software and other related information in the design of your equipments. AKM assumes no responsibility for any losses incurred by you or third parties arising from the use of these information herein. AKM assumes no liability for infringement of any patent, intellectual property, or other rights in the application or use of such information contained herein.
- Any export of these products, or devices or systems containing them, may require an export license or other official approval under the law and regulations of the country of export pertaining to customs and tariffs, currency exchange, or strategic materials.
- AKM products are neither intended nor authorized for use as critical components<sup>Note1)</sup> in any safety, life support, or other hazard related device or system<sup>Note2)</sup>, and AKM assumes no responsibility for such use, except for the use approved with the express written consent by Representative Director of AKM. As used here:
  - Note1) A critical component is one whose failure to function or perform may reasonably be expected to result, whether directly or indirectly, in the loss of the safety or effectiveness of the device or system containing it, and which must therefore meet very high standards of performance and reliability.
  - Note2) A hazard related device or system is one designed or intended for life support or maintenance of safety or for applications in medicine, aerospace, nuclear energy, or other fields, in which its failure to function or perform may reasonably be expected to result in loss of life or in significant injury or damage to person or property.
- It is the responsibility of the buyer or distributor of AKM products, who distributes, disposes of, or otherwise places the product with a third party, to notify such third party in advance of the above content and conditions, and the buyer or distributor agrees to assume any and all responsibility and liability for and hold AKM harmless from any and all claims arising from the use of said product in the absence of such notification.