

NXS0108-Q100

Dual supply translating transceiver; open drain;
auto direction sensing

Rev. 1 — 15 September 2020

Product data sheet

1. General description

The NXS0108-Q100 is an 8-bit, dual supply translating transceiver with auto direction sensing, that enables bidirectional voltage level translation. It features two 8-bit input-output ports (An and Bn), one output enable input (OE) and two supply pins ($V_{CC(A)}$ and $V_{CC(B)}$). $V_{CC(A)}$ can be supplied at any voltage between 1.2 V and 3.6 V and $V_{CC(B)}$ can be supplied at any voltage between 1.65 V and 5.5 V, making the device suitable for translating between any of the voltage nodes (1.2 V, 1.8 V, 2.5 V, 3.3 V and 5.0 V). Pins An and OE are referenced to $V_{CC(A)}$ and pins Bn are referenced to $V_{CC(B)}$. A LOW level at pin OE causes the outputs to assume a high-impedance OFF-state. This device is fully specified for partial power-down applications using I_{OFF} . The I_{OFF} circuitry disables the output, preventing the damaging backflow current through the device when it is powered down.

This product has been qualified to the Automotive Electronics Council (AEC) standard Q100 (Grade 1) and is suitable for use in automotive applications.

2. Features and benefits

- Automotive product qualification in accordance with AEC-Q100 (Grade 1)
 - Specified from -40 °C to +85 °C and from -40 °C to +125 °C
- Wide supply voltage range:
 - $V_{CC(A)}$: 1.2 V to 3.6 V and $V_{CC(B)}$: 1.65 V to 5.5 V
- Maximum data rates:
 - Push-pull: 110 Mbps
- I_{OFF} circuitry provides partial Power-down mode operation
- Inputs accept voltages up to 5.5 V
- ESD protection:
 - HBM JESD22-A114E Class 2 exceeds 2.5 kV for A port
 - HBM JESD22-A114E Class 3B exceeds 15 kV for B port
 - CDM JESD22-C101E exceeds 1.5 kV
 - IEC61000-4-2 contact discharge exceeds 8 kV for B port
- Latch-up performance exceeds 100 mA per JESD 78B Class II
- DHVQFN package with Side-Wettable Flanks enabling Automatic Optical Inspection (AOI) of solder joints

3. Ordering information

Table 1. Ordering information

| Type number | Package | | | |
|----------------|-------------------|----------|--|----------|
| | Temperature range | Name | Description | Version |
| NXS0108PW-Q100 | -40 °C to +125 °C | TSSOP20 | plastic thin shrink small outline package; 20 leads; body width 4.4 mm | SOT360-1 |
| NXS0108BQ-Q100 | -40 °C to +125 °C | DHVQFN20 | plastic dual in-line compatible thermal enhanced very thin quad flat package; no leads; 20 terminals; body 2.5 × 4.5 × 0.85 mm | SOT764-1 |

4. Functional diagram

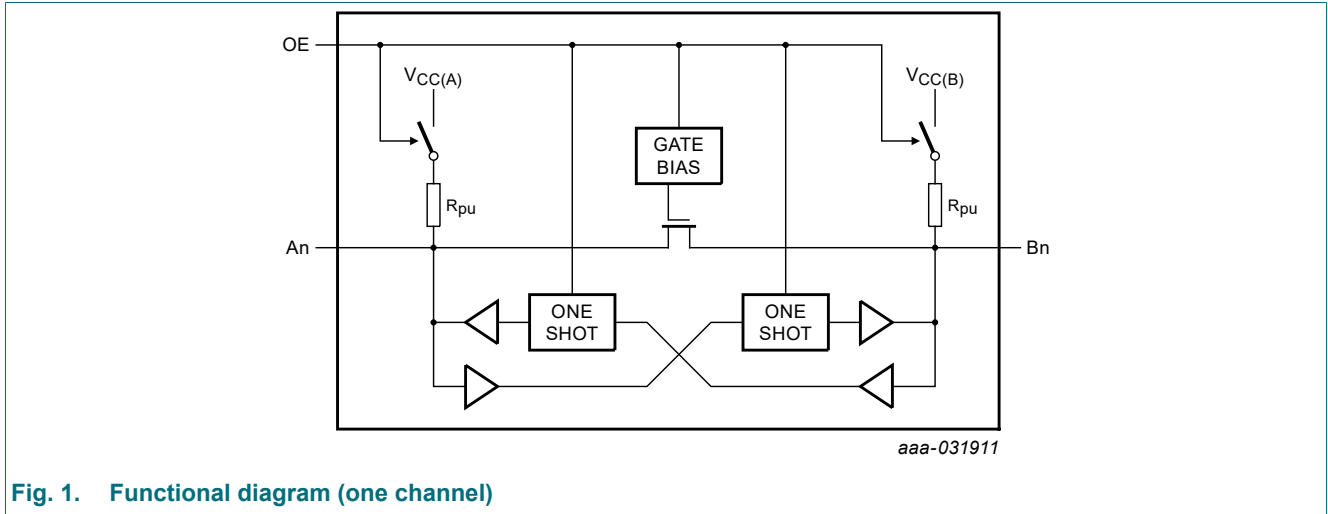

Fig. 1. Functional diagram (one channel)

5. Pinning information

5.1. Pinning

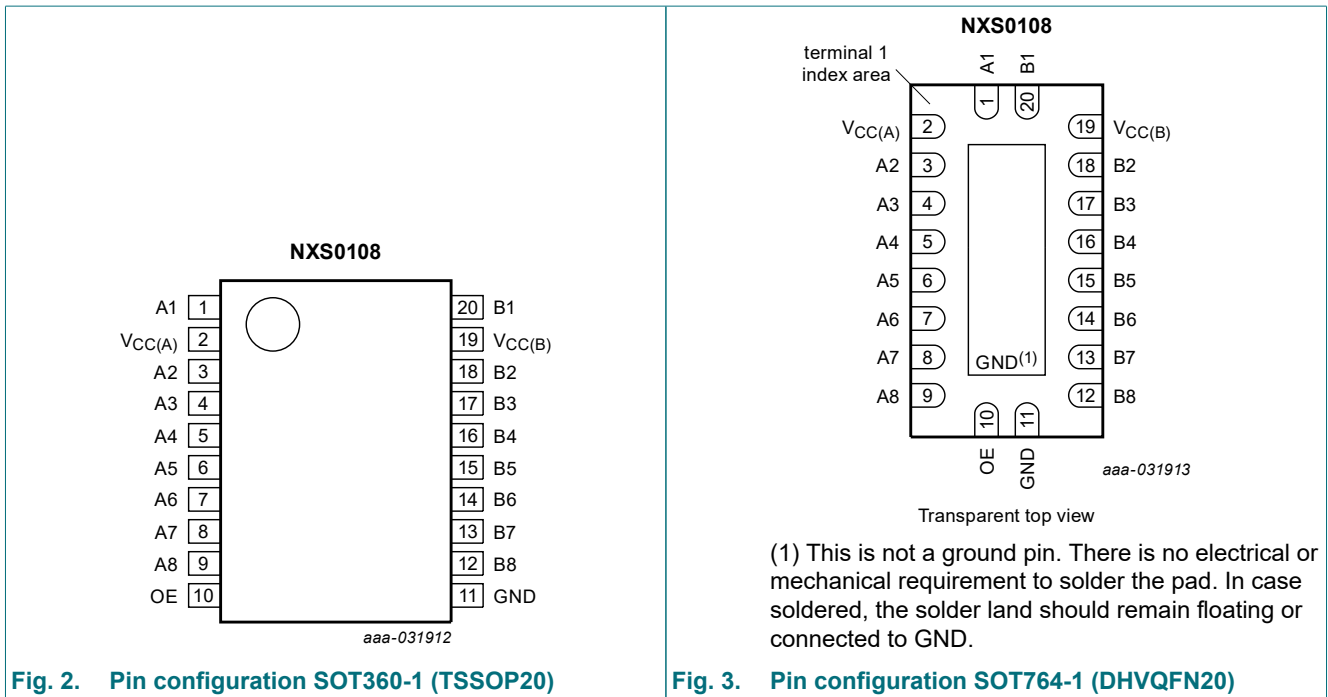

Fig. 2. Pin configuration SOT360-1 (TSSOP20)

Fig. 3. Pin configuration SOT764-1 (DHWQFN20)

5.2. Pin description

Table 2. Pin description

| Symbol | Pin | Description |
|--------------------------------|--------------------------------|---|
| A1, A2, A3, A4, A5, A6, A7, A8 | 1, 3, 4, 5, 6, 7, 8, 9 | data input or output (referenced to $V_{CC(A)}$) |
| $V_{CC(A)}$ | 2 | supply voltage A |
| OE | 10 | output enable input (active HIGH; referenced to $V_{CC(A)}$) |
| GND | 11 | ground (0 V) |
| B1, B2, B3, B4, B5, B6, B7, B8 | 20, 18, 17, 16, 15, 14, 13, 12 | data input or output (referenced to $V_{CC(B)}$) |
| $V_{CC(B)}$ | 19 | supply voltage B |

6. Functional description

Table 3. Function table

H = HIGH voltage level; L = LOW voltage level; X = don't care; Z = high-impedance OFF-state.

| Supply voltage | | Input | Input/output | |
|-----------------|-----------------|-------|-----------------|-----------------|
| $V_{CC(A)}$ [1] | $V_{CC(B)}$ | OE | A | B |
| 1.2 V to 3.6 V | 1.65 V to 5.5 V | L | Z | Z |
| 1.2 V to 3.6 V | 1.65 V to 5.5 V | H | input or output | output or input |
| GND | 1.65 V to 5.5 V | X | Z | Z |
| 1.2 V to 3.6 V | GND | X | Z | Z |

[1] $V_{CC(A)}$ must be less than or equal to $V_{CC(B)}$.

7. Limiting values

Table 4. Limiting values

In accordance with the Absolute Maximum Rating System (IEC 60134). Voltages are referenced to GND (ground = 0 V).

| Symbol | Parameter | Conditions | Min | Max | Unit |
|-------------|------------------|--|------|-----------------|------|
| $V_{CC(A)}$ | supply voltage A | | -0.5 | +6.5 | V |
| $V_{CC(B)}$ | supply voltage B | | -0.5 | +6.5 | V |
| V_I | input voltage | OE [1] | -0.5 | +6.5 | V |
| | | An, Bn; Power-down or 3-state mode [1] | -0.5 | +6.5 | V |
| | | An, Bn; Active mode [1] [2] [3] | -0.5 | $V_{CCI} + 0.5$ | V |
| V_O | output voltage | An, Bn; Power-down or 3-state mode [1] | -0.5 | +6.5 | V |
| | | An, Bn; Active mode [1] [3] [4] | -0.5 | $V_{CCO} + 0.5$ | V |

Dual supply translating transceiver; open drain; auto direction sensing

| Symbol | Parameter | Conditions | Min | Max | Unit |
|-----------|-------------------------|---|------|----------|------|
| I_{IK} | input clamping current | $V_I < 0\text{ V}$ | -50 | - | mA |
| I_{OK} | output clamping current | $V_O < 0\text{ V}$ | -50 | - | mA |
| I_O | output current | $V_O = 0\text{ V}$ to V_{CCO} [4] | - | ± 50 | mA |
| I_{CC} | supply current | $I_{CC(A)}$ or $I_{CC(B)}$ | - | 100 | mA |
| I_{GND} | ground current | | -100 | - | mA |
| T_{stg} | storage temperature | | -65 | +150 | °C |
| P_{tot} | total power dissipation | $T_{amb} = -40\text{ °C}$ to $+125\text{ °C}$ [5] | - | 500 | mW |

[1] The minimum input and minimum output voltage ratings may be exceeded if the input and output current ratings are observed.

[2] V_{CCI} is the supply voltage associated with the input.

[3] $V_{CCI} + 0.5\text{ V}$ or $V_{CCO} + 0.5\text{ V}$ should not exceed 6.5 V.

[4] V_{CCO} is the supply voltage associated with the output.

[5] For SOT360-1 (TSSOP20) package: P_{tot} derates linearly with 10.0 mW/K above 100 °C.
For SOT764-1 (DHVQFN20) package: P_{tot} derates linearly with 12.9 mW/K above 111 °C.

8. Recommended operating conditions

Table 5. Recommended operating conditions [1] [2]

| Symbol | Parameter | Conditions | Min | Max | Unit |
|---------------------|-------------------------------------|---|------|-----------|-----------|
| $V_{CC(A)}$ | supply voltage A | | 1.2 | 3.6 | V |
| $V_{CC(B)}$ | supply voltage B | | 1.65 | 5.5 | V |
| V_I | input voltage | OE | 0 | 5.5 | V |
| | | Power-down or 3-state mode | | | |
| | | An | 0 | 3.6 | V |
| | | Bn | 0 | 5.5 | V |
| | | Active mode | | | |
| | An, Bn | [3] | 0 | V_{CCI} | V |
| V_O | output voltage | Power-down or 3-state mode | | | |
| | | An | 0 | 3.6 | V |
| | | Bn | 0 | 5.5 | V |
| | | Active mode | | | |
| | | An, Bn | [4] | 0 | V_{CCO} |
| T_{amb} | ambient temperature | | -40 | +125 | °C |
| $\Delta t/\Delta V$ | input transition rise and fall rate | A or B port; push-pull driving | | | |
| | | $V_{CC(A)} = 1.2\text{ V}$ to 3.6 V ; $V_{CC(B)} = 1.65\text{ V}$ to 5.5 V | - | 10 | ns/V |
| | | OE input | | | |
| | | $V_{CC(A)} = 1.2\text{ V}$ to 3.6 V ; $V_{CC(B)} = 1.65\text{ V}$ to 5.5 V | - | 10 | ns/V |

[1] The A and B sides of an unused I/O pair must be held in the same state, both at V_{CCI} or both at GND.

[2] $V_{CC(A)}$ must be less than or equal to $V_{CC(B)}$.

[3] V_{CCI} is the supply voltage associated with the input.

[4] V_{CCO} is the supply voltage associated with the output.

9. Static characteristics

Table 6. Typical static characteristics

At recommended operating conditions; voltages are referenced to GND (ground = 0 V); $T_{amb} = 25\text{ }^{\circ}\text{C}$. [1]

| Symbol | Parameter | Conditions | Min | Typ | Max | Unit | |
|-----------|---------------------------|--|-----|------|---------|---------------|--|
| V_{OL} | LOW-level output voltage | A port; $V_I \leq 0.15\text{ V}$; $V_{CC(B)} = 1.65\text{ V to }5.5\text{ V}$; $V_{CC(A)} = 1.2\text{ V}$; $I_O = -135\text{ }\mu\text{A}$ | - | 0.25 | - | V | |
| I_I | input leakage current | OE input; $V_I = 0\text{ V to }3.6\text{ V}$; $V_{CC(A)} = 1.2\text{ V to }3.6\text{ V}$; $V_{CC(B)} = 1.65\text{ V to }5.5\text{ V}$ | - | - | ± 1 | μA | |
| I_{OZ} | OFF-state output current | A or B port; $V_O = 0\text{ V or }V_{CCO}$; $V_{CC(A)} = 1.2\text{ V to }3.6\text{ V}$; $V_{CC(B)} = 1.65\text{ V to }5.5\text{ V}$ [2] | - | - | ± 1 | μA | |
| I_{OFF} | power-off leakage current | A port; V_I or $V_O = 0\text{ V to }3.6\text{ V}$; $V_{CC(A)} = 0\text{ V}$; $V_{CC(B)} = 0\text{ V to }5.5\text{ V}$ | - | - | ± 1 | μA | |
| | | B port; V_I or $V_O = 0\text{ V to }5.5\text{ V}$; $V_{CC(B)} = 0\text{ V}$; $V_{CC(A)} = 0\text{ V to }3.6\text{ V}$ | - | - | ± 1 | μA | |
| C_I | input capacitance | OE input; $V_{CC(A)} = 3.3\text{ V}$; $V_{CC(B)} = 3.3\text{ V}$ | - | 2.6 | - | pF | |
| $C_{I/O}$ | input/output capacitance | A port; $V_{CC(A)} = 3.3\text{ V}$; $V_{CC(B)} = 3.3\text{ V}$ | | | | | |
| | | enabled | - | 9 | - | pF | |
| | | disabled | - | 5.2 | - | pF | |
| | | B port; $V_{CC(A)} = 3.3\text{ V}$; $V_{CC(B)} = 3.3\text{ V}$ | | | | | |
| | | enabled | - | 10.5 | - | pF | |
| disabled | - | 9 | - | pF | | | |

[1] $V_{CC(A)}$ must be less than or equal to $V_{CC(B)}$.

[2] V_{CCO} is the supply voltage associated with the output.

Table 7. Typical supply current

At recommended operating conditions; voltages are referenced to GND (ground = 0 V); $T_{amb} = 25\text{ }^{\circ}\text{C}$.

| $V_{CC(A)}$ | $V_{CC(B)}$ | | | | | | | | Unit |
|-------------|-------------|-------------|-------------|-------------|-------------|-------------|-------------|-------------|---------------|
| | 1.8 V | | 2.5 V | | 3.3 V | | 5.0 V | | |
| | $I_{CC(A)}$ | $I_{CC(B)}$ | $I_{CC(A)}$ | $I_{CC(B)}$ | $I_{CC(A)}$ | $I_{CC(B)}$ | $I_{CC(A)}$ | $I_{CC(B)}$ | |
| 1.2 V | 0.1 | 0.3 | 0.1 | 0.9 | 0.1 | 1.9 | 0.1 | 5.6 | μA |
| 1.5 V | 0.1 | 0.1 | 0.1 | 0.7 | 0.1 | 1.7 | 0.1 | 5 | μA |
| 1.8 V | 0.1 | 0.1 | 0.1 | 0.5 | 0.1 | 1.5 | 0.1 | 4.6 | μA |
| 2.5 V | - | - | 0.1 | 0.1 | 0.1 | 0.8 | 0.1 | 3.8 | μA |
| 3.3 V | - | - | - | - | 0.1 | 0.1 | 0.1 | 2.8 | μA |

Dual supply translating transceiver; open drain; auto direction sensing

Table 8. Static characteristics

At recommended operating conditions; voltages are referenced to GND (ground = 0 V).[1]

| Symbol | Parameter | Conditions | -40 °C to +85 °C | | -40 °C to +125 °C | | Unit |
|------------------|--|---|--------------------------|------------------------|--------------------------|------|------|
| | | | Min | Max | Min | Max | |
| V _{IH} | HIGH-level input voltage | A port | | | | | |
| | | V _{CC(A)} = 1.2 V to 1.95 V; V _{CC(B)} = 1.65 V to 5.5 V | V _{CC(A)} - 0.2 | - | V _{CC(A)} - 0.2 | - | V |
| | | V _{CC(A)} = 1.95 V to 3.6 V; V _{CC(B)} = 1.65 V to 5.5 V | V _{CC(A)} - 0.4 | - | V _{CC(A)} - 0.4 | - | V |
| | | B port | | | | | |
| | | V _{CC(A)} = 1.2 V to 3.6 V; V _{CC(B)} = 1.65 V to 5.5 V | V _{CC(B)} - 0.4 | - | V _{CC(B)} - 0.4 | - | V |
| | | OE input | | | | | |
| | V _{CC(A)} = 1.2 V to 3.6 V; V _{CC(B)} = 1.65 V to 5.5 V | 0.65V _{CC(A)} | - | 0.65V _{CC(A)} | - | V | |
| V _{IL} | LOW-level input voltage | A or B port | | | | | |
| | | V _{CC(A)} = 1.2 V to 3.6 V; V _{CC(B)} = 1.65 V to 5.5 V | - | 0.15 | - | 0.15 | V |
| | | OE input | | | | | |
| | V _{CC(A)} = 1.2 V to 3.6 V; V _{CC(B)} = 1.65 V to 5.5 V | - | 0.35V _{CC(A)} | - | 0.35V _{CC(A)} | V | |
| V _{OH} | HIGH-level output voltage | A port; I _O = -20 μA; V _I ≥ V _{CC(B)} - 0.4 V | | | | | |
| | | V _{CC(A)} = 1.2 V to 3.6 V; V _{CC(B)} = 1.65 V to 5.5 V | 0.67V _{CC(A)} | - | 0.67V _{CC(A)} | - | V |
| | | B port; I _O = -20 μA; V _I ≥ V _{CC(A)} - 0.2 V | | | | | |
| | | V _{CC(A)} = 1.2 V to 3.6 V; V _{CC(B)} = 1.65 V to 5.5 V | 0.67V _{CC(B)} | - | 0.67V _{CC(B)} | - | V |
| V _{OL} | LOW-level output voltage | A port; V _I ≤ 0.15 V; V _{CC(B)} = 1.65 V to 5.5 V | | | | | |
| | | V _{CC(A)} = 1.4 V; I _O = -180 μA | - | 0.4 | - | 0.4 | V |
| | | V _{CC(A)} = 1.65 V; I _O = -220 μA | - | 0.4 | - | 0.4 | V |
| | | V _{CC(A)} = 2.3 V; I _O = -300 μA | - | 0.4 | - | 0.4 | V |
| | | V _{CC(A)} = 3.0 V; I _O = -400 μA | - | 0.55 | - | 0.55 | V |
| | | B port; V _I ≤ 0.15 V; V _{CC(A)} = 1.2 V to 3.6 V | | | | | |
| | | V _{CC(B)} = 1.65 V; I _O = -220 μA | - | 0.4 | - | 0.4 | V |
| | | V _{CC(B)} = 2.3 V; I _O = -300 μA | - | 0.4 | - | 0.4 | V |
| | | V _{CC(B)} = 3.0 V; I _O = -400 μA | - | 0.55 | - | 0.55 | V |
| | | V _{CC(B)} = 4.5 V; I _O = -620 μA | - | 0.55 | - | 0.55 | V |
| I _I | input leakage current | OE input; V _I = 0 V to 3.6 V; V _{CC(A)} = 1.2 V to 3.6 V; V _{CC(B)} = 1.65 V to 5.5 V | - | ±2 | - | ±12 | μA |
| I _{OZ} | OFF-state output current | A or B port; V _O = 0 V or V _{CCO} ; V _{CC(A)} = 1.2 V to 3.6 V; V _{CC(B)} = 1.65 V to 5.5 V | [2] | ±2 | - | ±12 | μA |
| I _{OFF} | power-off leakage current | A port; V _I or V _O = 0 V to 3.6 V; V _{CC(A)} = 0 V; V _{CC(B)} = 0 V to 5.5 V | - | ±2 | - | ±12 | μA |
| | | B port; V _I or V _O = 0 V to 3.6 V; V _{CC(B)} = 0 V; V _{CC(A)} = 0 V to 5.5 V | - | ±2 | - | ±12 | μA |

Dual supply translating transceiver; open drain; auto direction sensing

| Symbol | Parameter | Conditions | -40 °C to +85 °C | | -40 °C to +125 °C | | Unit |
|-----------------|----------------|---|------------------|-----|-------------------|-----|------|
| | | | Min | Max | Min | Max | |
| I _{CC} | supply current | OE = 0 V or V _{CC(A)} ; An, Bn open | | | | | |
| | | I _{CC(A)} | | | | | |
| | | V _{CC(A)} = 1.2 V; V _{CC(B)} = 1.65 V to 5.5 V | -5 | 0.5 | -5 | 1 | μA |
| | | V _{CC(A)} = 1.5 V to 3.6 V; V _{CC(B)} = 2.3 V to 5.5 V | -2 | 1.2 | -2 | 2 | μA |
| | | V _{CC(A)} = 3.6 V; V _{CC(B)} = 0 V | - | 1.0 | - | 2 | μA |
| | | V _{CC(A)} = 0 V; V _{CC(B)} = 5.5 V | -1 | - | -1 | - | μA |
| | | I _{CC(B)} | | | | | |
| | | V _{CC(A)} = 1.2 V; V _{CC(B)} = 1.65 V to 5.5 V | - | 22 | - | 60 | μA |
| | | V _{CC(A)} = 1.5 V to 3.6 V; V _{CC(B)} = 2.3 V to 5.5 V | - | 20 | - | 20 | μA |
| | | V _{CC(A)} = 3.6 V; V _{CC(B)} = 0 V | -1 | - | -1 | - | μA |
| | | V _{CC(A)} = 0 V; V _{CC(B)} = 5.5 V | - | 2 | - | 12 | μA |
| | | I _{CC(A)} + I _{CC(B)} | | | | | |
| | | V _{CC(A)} = 1.2 V; V _{CC(B)} = 2.3 V to 5.5 V | - | 17 | - | 65 | μA |
| | | V _{CC(A)} = 1.5 V to 3.6 V; V _{CC(B)} = 2.3 V to 5.5 V | - | 20 | - | 20 | μA |

[1] V_{CC(A)} must be less than or equal to V_{CC(B)}.

[2] V_{CCO} is the supply voltage associated with the output.

10. Dynamic characteristics

Table 9. Typical dynamic characteristics

Voltages are referenced to GND (ground = 0 V); for test circuit see Fig. 7; for waveforms see Fig. 4 and Fig. 6.

| Symbol | Parameter | Conditions | V _{CC(B)} | | | | Unit |
|---|------------------------------------|-------------------------------|--------------------|------------------|------------------|------------------|------|
| | | | 1.8 V ± 0.15 V | 2.5 V ± 0.2 V | 3.3 V ± 0.3 V | 5.0 V ± 0.5 V | |
| V_{CC(A)} = 1.2 V; T_{amb} = 25 °C | | | | | | | |
| t _{PHL} | HIGH to LOW propagation delay | A to B | 6.5 | 5.9 | 5.7 | 5.5 | ns |
| t _{PLH} | LOW to HIGH propagation delay | A to B | 7.1 | 6.3 | 6.2 | 6.6 | ns |
| t _{PHL} | HIGH to LOW propagation delay | B to A | 6.2 | 5.4 | 5.1 | 5 | ns |
| t _{PLH} | LOW to HIGH propagation delay | B to A | 5.6 | 4.1 | 3.6 | 3.2 | ns |
| t _{en} | enable time | OE to A; B [1] | 200 | 200 | 200 | 200 | ns |
| t _{dis} | disable time | OE to A; no external load [1] | 12 | 12 | 12 | 12 | ns |
| | | OE to B; no external load [2] | 12 | 12 | 12 | 12 | ns |
| | | OE to A; see Fig. 5 | 90 | 90 | 90 | 90 | ns |
| | | OE to B; see Fig. 5 | 95 | 75 | 100 | 75 | ns |
| t _{TLH} | LOW to HIGH output transition time | A port | 6.5 | 5.2 | 4.8 | 4.4 | ns |
| | | B port | 6.6 | 4.3 | 2.1 | 1.5 | ns |
| t _{THL} | HIGH to LOW output transition time | A port | 5.8 | 4.8 | 4.3 | 3.8 | ns |
| | | B port | 3.6 | 2.2 | 1.8 | 1.5 | ns |
| t _{sk(o)} | output skew time | between channels [3] | 1 | 1 | 1 | 1 | ns |
| t _W | pulse width | data inputs | 20 | 16.7 | 16.7 | 16.7 | ns |
| f _{data} | data rate | | 50 | 60 | 60 | 60 | Mbps |

[1] t_{en} is the same as t_{pZL} and t_{pZH}; t_{dis} is the same as t_{pLZ} and t_{pHZ}.

[2] These values are guaranteed by design.

[3] Skew between any two outputs of the same package switching in the same direction.

Dual supply translating transceiver; open drain; auto direction sensing

Table 10. Dynamic characteristics for temperature range -40 °C to +85 °C

Voltages are referenced to GND (ground = 0 V); for test circuit see Fig. 7; for waveforms see Fig. 4 and Fig. 6.

| Symbol | Parameter | Conditions | V _{CC(B)} | | | | | | | | Unit |
|---|------------------------------------|-------------------------------|--------------------|------|------------------|------|------------------|-----|------------------|-----|------|
| | | | 1.8 V ± 0.15 V | | 2.5 V ± 0.2 V | | 3.3 V ± 0.3 V | | 5.0 V ± 0.5 V | | |
| | | | Min | Max | Min | Max | Min | Max | Min | Max | |
| V_{CC(A)} = 1.5 V ± 0.1 V | | | | | | | | | | | |
| t _{PHL} | HIGH to LOW propagation delay | A to B | - | 11 | - | 9.2 | - | 8.6 | - | 8.6 | ns |
| t _{PLH} | LOW to HIGH propagation delay | A to B | - | 12.6 | - | 10 | - | 9.8 | - | 9.7 | ns |
| t _{PHL} | HIGH to LOW propagation delay | B to A | - | 12.7 | - | 11.1 | - | 11 | - | 12 | ns |
| t _{PLH} | LOW to HIGH propagation delay | B to A | - | 10.5 | - | 6.9 | - | 5.6 | - | 4.6 | ns |
| t _{en} | enable time | OE to A; B [1] | - | 200 | - | 200 | - | 200 | - | 200 | ns |
| t _{dis} | disable time | OE to A; no external load [1] | - | 17 | - | 17 | - | 17 | - | 17 | ns |
| | | OE to B; no external load [2] | - | 18 | - | 17 | - | 17 | - | 17 | ns |
| | | OE to A; see Fig. 5 | - | 120 | - | 120 | - | 120 | - | 125 | ns |
| | | OE to B; see Fig. 5 | - | 170 | - | 125 | - | 175 | - | 125 | ns |
| t _{TLH} | LOW to HIGH output transition time | A port | 2.6 | 13.1 | 2.8 | 9.8 | 2.0 | 9.0 | 2.0 | 8.3 | ns |
| | | B port | 2.9 | 11.4 | 1.9 | 8.1 | 0.9 | 5.3 | 0.7 | 3 | ns |
| t _{THL} | HIGH to LOW output transition time | A port | 2.1 | 9.9 | 1.5 | 7.7 | 1.2 | 6.8 | 0.8 | 6.0 | ns |
| | | B port | 1.5 | 8.7 | 1.0 | 5.5 | 0.9 | 3.8 | 0.8 | 3.1 | ns |
| t _{sk(o)} | output skew time | between channels [3] | - | 1 | - | 1 | - | 1.1 | - | 1 | ns |
| t _W | pulse width | data inputs | 20 | - | 20 | - | 20 | - | 20 | - | ns |
| f _{data} | data rate | | - | 50 | - | 50 | - | 50 | - | 50 | Mbps |
| V_{CC(A)} = 1.8 V ± 0.15 V | | | | | | | | | | | |
| t _{PHL} | HIGH to LOW propagation delay | A to B | - | 9.7 | - | 7.3 | - | 6.5 | - | 5.9 | ns |
| t _{PLH} | LOW to HIGH propagation delay | A to B | - | 11.3 | - | 8.4 | - | 7.4 | - | 6.5 | ns |
| t _{PHL} | HIGH to LOW propagation delay | B to A | - | 9.8 | - | 8.0 | - | 7.4 | - | 7.0 | ns |
| t _{PLH} | LOW to HIGH propagation delay | B to A | - | 10.2 | - | 7.0 | - | 5.8 | - | 5.0 | ns |
| t _{en} | enable time | OE to A; B [1] | - | 200 | - | 200 | - | 200 | - | 200 | ns |
| t _{dis} | disable time | OE to A; no external load [1] | - | 13 | - | 13 | - | 13 | - | 13 | ns |
| | | OE to B; no external load [2] | - | 16 | - | 13 | - | 13 | - | 13 | ns |
| | | OE to A; see Fig. 5 | - | 140 | - | 140 | - | 140 | - | 145 | ns |
| | | OE to B; see Fig. 5 | - | 165 | - | 125 | - | 175 | - | 125 | ns |
| t _{TLH} | LOW to HIGH output transition time | A port | 2.2 | 11.9 | 2.0 | 8.6 | 1.9 | 7.8 | 1.9 | 7.2 | ns |
| | | B port | 2.8 | 12.2 | 1.8 | 7.7 | 1.2 | 5.3 | 0.7 | 2.9 | ns |
| t _{THL} | HIGH to LOW output transition time | A port | 1.8 | 8.8 | 1.3 | 6.6 | 0.9 | 5.7 | 0.6 | 4.9 | ns |
| | | B port | 1.3 | 8.3 | 1.0 | 5.4 | 0.9 | 3.9 | 0.7 | 3.0 | ns |
| t _{sk(o)} | output skew time | between channels [3] | - | 1 | - | 1 | - | 1 | - | 1 | ns |
| t _W | pulse width | data inputs | 22.2 | - | 16.7 | - | 16.7 | - | 16.7 | - | ns |
| f _{data} | data rate | | - | 45 | - | 60 | - | 60 | - | 60 | Mbps |

Dual supply translating transceiver; open drain; auto direction sensing

| Symbol | Parameter | Conditions | $V_{CC(B)}$ | | | | | | | | Unit |
|---------------------------------|------------------------------------|-------------------------------|-----------------------|-----|----------------------|-----|----------------------|-----|----------------------|-----|------|
| | | | 1.8 V ± 0.15 V | | 2.5 V ± 0.2 V | | 3.3 V ± 0.3 V | | 5.0 V ± 0.5 V | | |
| | | | Min | Max | Min | Max | Min | Max | Min | Max | |
| $V_{CC(A)} = 2.5$ V ± 0.2 V | | | | | | | | | | | |
| t_{PHL} | HIGH to LOW propagation delay | A to B | - | - | - | 6.2 | - | 5.3 | - | 4.7 | ns |
| t_{PLH} | LOW to HIGH propagation delay | A to B | - | - | - | 6.8 | - | 5.9 | - | 5.2 | ns |
| t_{PHL} | HIGH to LOW propagation delay | B to A | - | - | - | 5.9 | - | 4.8 | - | 4.2 | ns |
| t_{PLH} | LOW to HIGH propagation delay | B to A | - | - | - | 6.2 | - | 4.6 | - | 3.6 | ns |
| t_{en} | enable time | OE to A; B [1] | - | - | - | 200 | - | 200 | - | 200 | ns |
| t_{dis} | disable time | OE to A; no external load [1] | - | - | - | 9 | - | 9 | - | 9 | ns |
| | | OE to B; no external load [2] | - | - | - | 11 | - | 9 | - | 9 | ns |
| | | OE to A; see Fig. 5 | - | - | - | 105 | - | 105 | - | 105 | ns |
| | | OE to B; see Fig. 5 | - | - | - | 125 | - | 175 | - | 120 | ns |
| t_{TLH} | LOW to HIGH output transition time | A port | - | - | 1.7 | 7.3 | 1.7 | 6.4 | 1.8 | 5.8 | ns |
| | | B port | - | - | 1.8 | 7.3 | 1.3 | 5.4 | 0.8 | 3.3 | ns |
| t_{THL} | HIGH to LOW output transition time | A port | - | - | 1.3 | 5.7 | 0.8 | 4.7 | 0.6 | 3.8 | ns |
| | | B port | - | - | 1.1 | 5.4 | 0.9 | 4.1 | 0.7 | 3.0 | ns |
| $t_{sk(o)}$ | output skew time | between channels [3] | - | - | - | 1 | - | 1.2 | - | 1 | ns |
| t_W | pulse width | data inputs | - | - | 14 | - | 11 | - | 11 | - | ns |
| f_{data} | data rate | | - | - | - | 70 | - | 90 | - | 90 | Mbps |

Dual supply translating transceiver; open drain; auto direction sensing

| Symbol | Parameter | Conditions | V _{CC(B)} | | | | | | | | Unit |
|--|------------------------------------|-------------------------------|--------------------|-----|------------------|-----|------------------|-----|------------------|-----|------|
| | | | 1.8 V ± 0.15 V | | 2.5 V ± 0.2 V | | 3.3 V ± 0.3 V | | 5.0 V ± 0.5 V | | |
| | | | Min | Max | Min | Max | Min | Max | Min | Max | |
| V_{CC(A)} = 3.3 V ± 0.3 V | | | | | | | | | | | |
| t _{PHL} | HIGH to LOW propagation delay | A to B | - | - | - | - | - | 4.9 | - | 4.2 | ns |
| t _{PLH} | LOW to HIGH propagation delay | A to B | - | - | - | - | - | 5.2 | - | 4.6 | ns |
| t _{PHL} | HIGH to LOW propagation delay | B to A | - | - | - | - | - | 4.7 | - | 3.8 | ns |
| t _{PLH} | LOW to HIGH propagation delay | B to A | - | - | - | - | - | 4.7 | - | 4.3 | ns |
| t _{en} | enable time | OE to A; B [1] | - | - | - | - | - | 200 | - | 200 | ns |
| t _{dis} | disable time | OE to A; no external load [1] | - | - | - | - | - | 8 | - | 8 | ns |
| | | OE to B; no external load [2] | - | - | - | - | - | 8 | - | 8 | ns |
| | | OE to A; see Fig. 5 | - | - | - | - | - | 150 | - | 150 | ns |
| | | OE to B; see Fig. 5 | - | - | - | - | - | 170 | - | 120 | ns |
| t _{TLH} | LOW to HIGH output transition time | A port | - | - | - | - | 1.6 | 5.7 | 1.8 | 5.0 | ns |
| | | B port | - | - | - | - | 1.5 | 5.4 | 0.9 | 3.9 | ns |
| t _{THL} | HIGH to LOW output transition time | A port | - | - | - | - | 1.0 | 4.5 | 0.6 | 3.5 | ns |
| | | B port | - | - | - | - | 1.0 | 4.2 | 0.8 | 3.1 | ns |
| t _{sk(o)} | output skew time | between channels [3] | - | - | - | - | - | 1 | - | 1 | ns |
| t _W | pulse width | data inputs | - | - | - | - | 11 | - | 9 | - | ns |
| f _{data} | data rate | | - | - | - | - | - | 90 | - | 110 | Mbps |

[1] t_{en} is the same as t_{PZL} and t_{PZH}; t_{dis} is the same as t_{PLZ} and t_{PHZ}.
 [2] These values are guaranteed by design.
 [3] Skew between any two outputs of the same package switching in the same direction.

Dual supply translating transceiver; open drain; auto direction sensing

Table 11. Dynamic characteristics for temperature range -40 °C to +125 °C

Voltages are referenced to GND (ground = 0 V); for test circuit see Fig. 7; for waveforms see Fig. 4 and Fig. 6.

| Symbol | Parameter | Conditions | V _{CC(B)} | | | | | | | | Unit |
|---|------------------------------------|-------------------------------|--------------------|------|------------------|------|------------------|------|------------------|------|------|
| | | | 1.8 V ± 0.15 V | | 2.5 V ± 0.2 V | | 3.3 V ± 0.3 V | | 5.0 V ± 0.5 V | | |
| | | | Min | Max | Min | Max | Min | Max | Min | Max | |
| V_{CC(A)} = 1.5 V ± 0.1 V | | | | | | | | | | | |
| t _{PHL} | HIGH to LOW propagation delay | A to B | - | 13.8 | - | 11.5 | - | 10.8 | - | 10.8 | ns |
| t _{PLH} | LOW to HIGH propagation delay | A to B | - | 15.8 | - | 12.5 | - | 12.3 | - | 12.1 | ns |
| t _{PHL} | HIGH to LOW propagation delay | B to A | - | 15.9 | - | 13.9 | - | 13.8 | - | 15.0 | ns |
| t _{PLH} | LOW to HIGH propagation delay | B to A | - | 13.1 | - | 8.6 | - | 7.0 | - | 5.8 | ns |
| t _{en} | enable time | OE to A; B [1] | - | 200 | - | 200 | - | 200 | - | 200 | ns |
| t _{dis} | disable time | OE to A; no external load [1] | - | 18 | - | 18 | - | 18 | - | 18 | ns |
| | | OE to B; no external load [2] | - | 19 | - | 18 | - | 18 | - | 18 | ns |
| | | OE to A; see Fig. 5 | - | 120 | - | 120 | - | 120 | - | 125 | ns |
| | | OE to B; see Fig. 5 | - | 170 | - | 125 | - | 175 | - | 125 | ns |
| t _{TLH} | LOW to HIGH output transition time | A port | 2.6 | 16.4 | 2.8 | 12.3 | 2.0 | 11.3 | 2.0 | 10.4 | ns |
| | | B port | 2.9 | 16.1 | 1.9 | 10.1 | 0.9 | 6.6 | 0.7 | 3.8 | ns |
| t _{THL} | HIGH to LOW output transition time | A port | 2.1 | 12.4 | 1.5 | 9.6 | 1.2 | 8.5 | 0.8 | 7.5 | ns |
| | | B port | 1.5 | 10.9 | 1.0 | 6.9 | 0.9 | 4.8 | 0.8 | 3.9 | ns |
| t _{sk(o)} | output skew time | between channels [3] | - | 1.1 | - | 1.1 | - | 1.2 | - | 1.1 | ns |
| t _W | pulse width | data inputs | 25 | - | 25 | - | 25 | - | 25 | - | ns |
| f _{data} | data rate | | - | 40 | - | 40 | - | 40 | - | 40 | Mbps |
| V_{CC(A)} = 1.8 V ± 0.15 V | | | | | | | | | | | |
| t _{PHL} | HIGH to LOW propagation delay | A to B | - | 12.1 | - | 9.1 | - | 8.1 | - | 7.4 | ns |
| t _{PLH} | LOW to HIGH propagation delay | A to B | - | 14.1 | - | 10.5 | - | 9.3 | - | 8.1 | ns |
| t _{PHL} | HIGH to LOW propagation delay | B to A | - | 12.3 | - | 10.0 | - | 9.3 | - | 8.8 | ns |
| t _{PLH} | LOW to HIGH propagation delay | B to A | - | 12.8 | - | 8.8 | - | 7.3 | - | 6.3 | ns |
| t _{en} | enable time | OE to A; B [1] | - | 200 | - | 200 | - | 200 | - | 200 | ns |
| t _{dis} | disable time | OE to A; no external load [1] | - | 14 | - | 14 | - | 14 | - | 14 | ns |
| | | OE to B; no external load [2] | - | 17 | - | 14 | - | 14 | - | 14 | ns |
| | | OE to A; see Fig. 5 | - | 140 | - | 140 | - | 140 | - | 145 | ns |
| | | OE to B; see Fig. 5 | - | 165 | - | 125 | - | 175 | - | 125 | ns |
| t _{TLH} | LOW to HIGH output transition time | A port | 2.2 | 14.9 | 2.0 | 10.8 | 1.9 | 9.8 | 1.9 | 9.0 | ns |
| | | B port | 2.8 | 15.3 | 1.8 | 9.6 | 1.2 | 6.6 | 0.7 | 3.6 | ns |
| t _{THL} | HIGH to LOW output transition time | A port | 1.8 | 11.0 | 1.3 | 8.3 | 0.9 | 7.1 | 0.6 | 6.1 | ns |
| | | B port | 1.3 | 10.4 | 1.0 | 6.8 | 0.9 | 4.9 | 0.7 | 3.8 | ns |
| t _{sk(o)} | output skew time | between channels [3] | - | 1.1 | - | 1.1 | - | 1.1 | - | 1.1 | ns |
| t _W | pulse width | data inputs | 25 | - | 20 | - | 20 | - | 20 | - | ns |
| f _{data} | data rate | | - | 40 | - | 50 | - | 50 | - | 50 | Mbps |

Dual supply translating transceiver; open drain; auto direction sensing

| Symbol | Parameter | Conditions | V _{CC(B)} | | | | | | | | Unit |
|--|------------------------------------|-------------------------------|--------------------|-----|------------------|-----|------------------|-----|------------------|-----|------|
| | | | 1.8 V ± 0.15 V | | 2.5 V ± 0.2 V | | 3.3 V ± 0.3 V | | 5.0 V ± 0.5 V | | |
| | | | Min | Max | Min | Max | Min | Max | Min | Max | |
| V_{CC(A)} = 2.5 V ± 0.2 V | | | | | | | | | | | |
| t _{PHL} | HIGH to LOW propagation delay | A to B | - | - | - | 7.8 | - | 6.6 | - | 5.9 | ns |
| t _{PLH} | LOW to HIGH propagation delay | A to B | - | - | - | 8.5 | - | 7.4 | - | 6.5 | ns |
| t _{PHL} | HIGH to LOW propagation delay | B to A | - | - | - | 7.4 | - | 6.0 | - | 5.3 | ns |
| t _{PLH} | LOW to HIGH propagation delay | B to A | - | - | - | 7.8 | - | 5.8 | - | 4.5 | ns |
| t _{en} | enable time | OE to A; B [1] | - | - | - | 200 | - | 200 | - | 200 | ns |
| t _{dis} | disable time | OE to A; no external load [1] | - | - | - | 10 | - | 10 | - | 10 | ns |
| | | OE to B; no external load [2] | - | - | - | 12 | - | 10 | - | 10 | ns |
| | | OE to A; see Fig. 5 | - | - | - | 105 | - | 105 | - | 105 | ns |
| | | OE to B; see Fig. 5 | - | - | - | 125 | - | 175 | - | 120 | ns |
| t _{TLH} | LOW to HIGH output transition time | A port | - | - | 1.7 | 9.1 | 1.7 | 8.0 | 1.8 | 7.3 | ns |
| | | B port | - | - | 1.8 | 9.1 | 1.3 | 6.8 | 0.9 | 4.1 | ns |
| t _{THL} | HIGH to LOW output transition time | A port | - | - | 1.3 | 7.1 | 0.8 | 5.9 | 0.6 | 4.8 | ns |
| | | B port | - | - | 1.1 | 6.8 | 0.9 | 5.1 | 0.7 | 3.8 | ns |
| t _{sk(o)} | output skew time | between channels [3] | - | - | - | 1.1 | - | 1.3 | - | 1.1 | ns |
| t _W | pulse width | data inputs | - | - | 16.7 | - | 12.5 | - | 12.5 | - | ns |
| f _{data} | data rate | | - | - | - | 60 | - | 80 | - | 80 | Mbps |

Dual supply translating transceiver; open drain; auto direction sensing

| Symbol | Parameter | Conditions | V _{CC(B)} | | | | | | | | Unit |
|--|------------------------------------|-------------------------------|--------------------|-----|------------------|-----|------------------|-----|------------------|-----|------|
| | | | 1.8 V ± 0.15 V | | 2.5 V ± 0.2 V | | 3.3 V ± 0.3 V | | 5.0 V ± 0.5 V | | |
| | | | Min | Max | Min | Max | Min | Max | Min | Max | |
| V_{CC(A)} = 3.3 V ± 0.3 V | | | | | | | | | | | |
| t _{PHL} | HIGH to LOW propagation delay | A to B | - | - | - | - | - | 6.1 | - | 5.3 | ns |
| t _{PLH} | LOW to HIGH propagation delay | A to B | - | - | - | - | - | 6.5 | - | 5.8 | ns |
| t _{PHL} | HIGH to LOW propagation delay | B to A | - | - | - | - | - | 5.9 | - | 4.8 | ns |
| t _{PLH} | LOW to HIGH propagation delay | B to A | - | - | - | - | - | 5.9 | - | 5.4 | ns |
| t _{en} | enable time | OE to A; B [1] | - | - | - | - | - | 200 | - | 200 | ns |
| t _{dis} | disable time | OE to A; no external load [1] | - | - | - | - | - | 9 | - | 9 | ns |
| | | OE to B; no external load [2] | - | - | - | - | - | 9 | - | 9 | ns |
| | | OE to A; see Fig. 5 | - | - | - | - | - | 150 | - | 150 | ns |
| | | OE to B; see Fig. 5 | - | - | - | - | - | 170 | - | 120 | ns |
| t _{TLH} | LOW to HIGH output transition time | A port | - | - | - | - | 1.6 | 7.1 | 1.8 | 6.3 | ns |
| | | B port | - | - | - | - | 1.5 | 6.8 | 0.9 | 4.9 | ns |
| t _{THL} | HIGH to LOW output transition time | A port | - | - | - | - | 1.0 | 5.6 | 0.7 | 4.4 | ns |
| | | B port | - | - | - | - | 1.0 | 5.3 | 0.8 | 3.9 | ns |
| t _{sk(o)} | output skew time | between channels [3] | - | - | - | - | - | 1.1 | - | 1.1 | ns |
| t _W | pulse width | data inputs | - | - | - | - | 13 | - | 10 | - | ns |
| f _{data} | data rate | | - | - | - | - | - | 80 | - | 100 | Mbps |

[1] t_{en} is the same as t_{PZL} and t_{PZH}; t_{dis} is the same as t_{PLZ} and t_{PHZ}.

[2] These values are guaranteed by design.

[3] Skew between any two outputs of the same package switching in the same direction.

Dual supply translating transceiver; open drain; auto direction sensing

Table 12. Typical power dissipation capacitance

Voltages are referenced to GND (ground = 0 V); for test circuit see Fig. 7 [1] [2]

| Symbol | Parameter | Conditions | V _{CC(A)} | | | | | | | Unit | |
|--------------------------------|-------------------------------|--|--------------------|-------|-------|-------|-------|-------|----------------|------|--|
| | | | 1.2 V | 1.2 V | 1.5 V | 1.8 V | 2.5 V | 2.5 V | 3.3 V | | |
| | | | V _{CC(B)} | | | | | | | | |
| | | | 1.8 V | 5.0 V | 1.8 V | 1.8 V | 2.5 V | 5.0 V | 3.3 V to 5.0 V | | |
| T_{amb} = 25 °C | | | | | | | | | | | |
| C _{PD} | power dissipation capacitance | outputs enabled; OE = V _{CC(A)} | | | | | | | | | |
| | | A port: (direction A to B) | 7.7 | 7.4 | 8.0 | 8.3 | 8.4 | 8.0 | 8.7 | pF | |
| | | A port: (direction B to A) | 5.9 | 6.3 | 6.6 | 7.5 | 8.2 | 7.0 | 8.5 | pF | |
| | | B port: (direction A to B) | 20.8 | 26.6 | 19.9 | 19.7 | 20.0 | 24.3 | 22.2 | pF | |
| | | B port: (direction B to A) | 18.9 | 23.8 | 18.4 | 18.4 | 19.0 | 21.2 | 20.3 | pF | |
| | | outputs disabled; OE = GND | | | | | | | | | |
| | | A port: (direction A to B) | 0.01 | 0.01 | 0.01 | 0.01 | 0.01 | 0.01 | 0.01 | pF | |
| | | A port: (direction B to A) | 0.01 | 0.01 | 0.01 | 0.01 | 0.01 | 0.01 | 0.01 | pF | |
| | | B port: (direction A to B) | 0.01 | 0.02 | 0.01 | 0.01 | 0.01 | 0.01 | 0.01 | pF | |
| | | B port: (direction B to A) | 0.01 | 0.03 | 0.01 | 0.01 | 0.01 | 0.01 | 0.01 | pF | |

[1] C_{PD} is used to determine the dynamic power dissipation (P_D in μW).

$$P_D = C_{PD} \times V_{CC}^2 \times f_i \times N + \sum(C_L \times V_{CC}^2 \times f_o) \text{ where:}$$

f_i = input frequency in MHz; f_o = output frequency in MHz; C_L = load capacitance in pF;

V_{CC} = supply voltage in V; N = number of inputs switching; $\sum(C_L \times V_{CC}^2 \times f_o)$ = sum of the outputs.

[2] f_i = 10 MHz; V_I = GND to V_{CC}; t_r = t_f = 1 ns; C_L = 0 pF; R_L = ∞ Ω.

10.1. Waveforms and test circuit

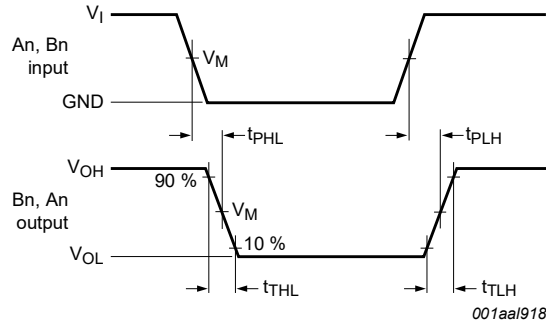

Measurement points are given in [Table 13](#).

V_{OL} and V_{OH} are typical output voltage levels that occur with the output load.

Fig. 4. The data input (An, Bn) to data output (Bn, An) propagation delay times

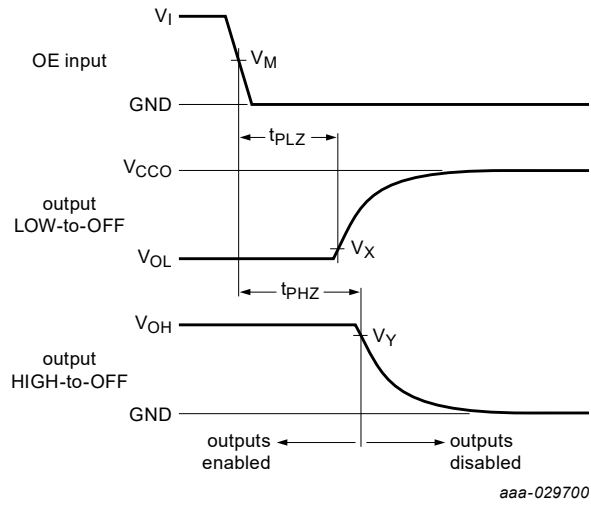

Measurement points are given in [Table 13](#).

V_{OL} and V_{OH} are typical output voltage levels that occur with the output load.

V_{CCO} is the supply voltage associated with the output.

Fig. 5. Disable times

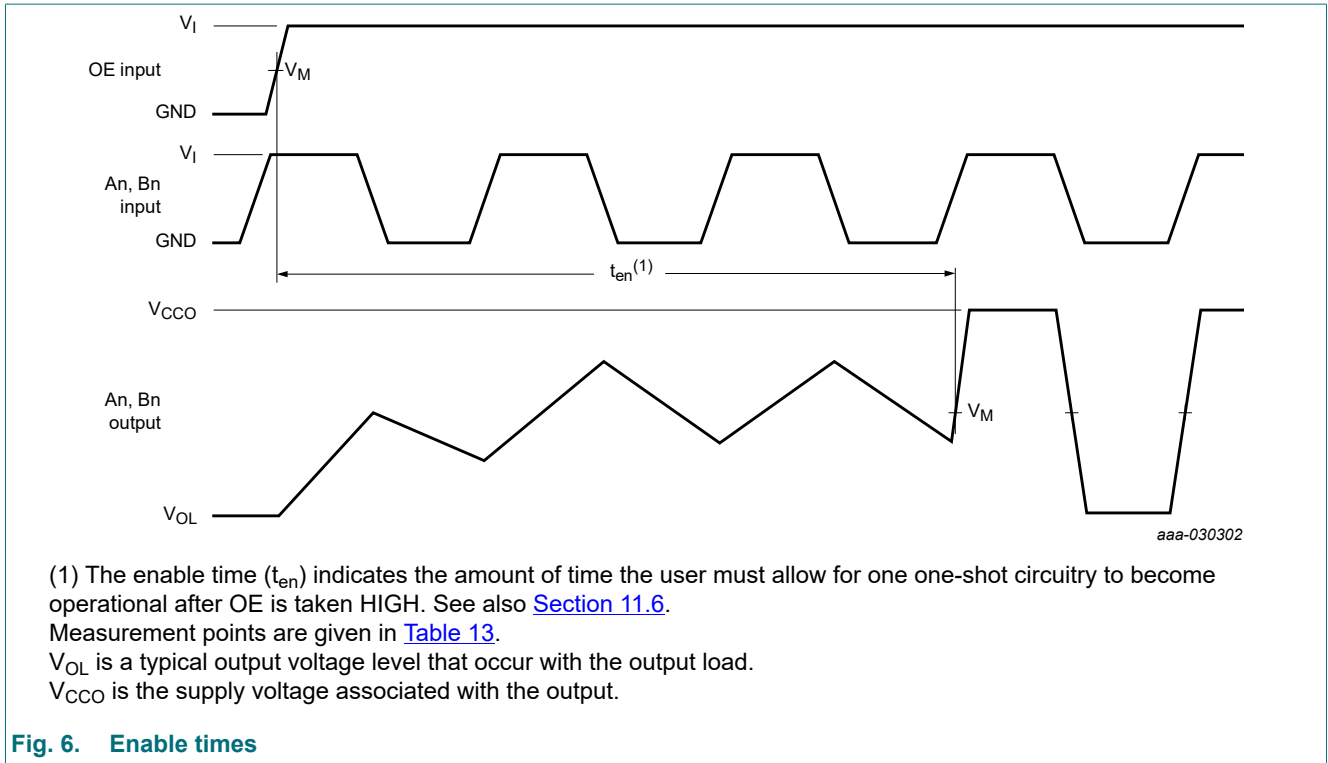

Fig. 6. Enable times

Table 13. Measurement points [1] [2]

| Supply voltage | Input | Output | | |
|--------------------|--------------|--------------|-------------------|-------------------|
| | V_M | V_M | V_X | V_Y |
| 1.2 V | $0.5V_{CCI}$ | $0.5V_{CCO}$ | $V_{OL} + 0.1 V$ | $V_{OH} - 0.1 V$ |
| $1.5 V \pm 0.1 V$ | $0.5V_{CCI}$ | $0.5V_{CCO}$ | $V_{OL} + 0.1 V$ | $V_{OH} - 0.1 V$ |
| $1.8 V \pm 0.15 V$ | $0.5V_{CCI}$ | $0.5V_{CCO}$ | $V_{OL} + 0.15 V$ | $V_{OH} - 0.15 V$ |
| $2.5 V \pm 0.2 V$ | $0.5V_{CCI}$ | $0.5V_{CCO}$ | $V_{OL} + 0.15 V$ | $V_{OH} - 0.15 V$ |
| $3.3 V \pm 0.3 V$ | $0.5V_{CCI}$ | $0.5V_{CCO}$ | $V_{OL} + 0.3 V$ | $V_{OH} - 0.3 V$ |
| $5.0 V \pm 0.5 V$ | $0.5V_{CCI}$ | $0.5V_{CCO}$ | $V_{OL} + 0.3 V$ | $V_{OH} - 0.3 V$ |

[1] V_{CCI} is the supply voltage associated with the input.
 [2] V_{CCO} is the supply voltage associated with the output.

Dual supply translating transceiver; open drain; auto direction sensing

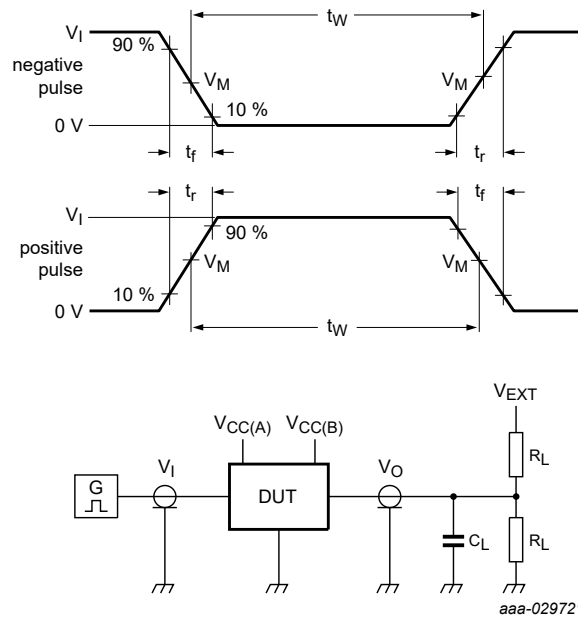

Test data is given in [Table 14](#).

All input pulses are supplied by generators having the following characteristics:

PRR ≤ 10 MHz; Z_O = 50 Ω; dV/dt ≥ 1.0 V/ns.

R_L = Load resistance.

C_L = Load capacitance including jig and probe capacitance.

V_{EXT} = External voltage for measuring switching times.

Fig. 7. Test circuit for measuring switching times

Table 14. Test data

| Supply voltage | | Input | | Load | | V _{EXT} | | |
|--------------------|--------------------|--------------------|------------|----------------|--------------------|-------------------------------------|-------------------------------------|---|
| V _{CC(A)} | V _{CC(B)} | V _I [1] | Δt/ΔV | C _L | R _L [2] | t _{PLH} , t _{PHL} | t _{PZH} , t _{PHZ} | t _{PZL} , t _{PLZ} [3] |
| 1.2 V to 3.6 V | 1.65 V to 5.5 V | V _{CCI} | ≤ 1.0 ns/V | 15 pF | 50 kΩ, 1 MΩ | open | open | 2V _{CCO} |

[1] V_{CCI} is the supply voltage associated with the input.

[2] For measuring data rate, pulse width, propagation delay and output rise and fall measurements, R_L = 1 MΩ; for measuring enable and disable times, R_L = 50 kΩ.

[3] V_{CCO} is the supply voltage associated with the output.

11. Application information

11.1. Voltage level-translation applications

The NXS0108-Q100 can be used in point-to-point applications to interface between devices or systems operating at different supply voltages. The device is primarily targeted at I²C or 1-wire which use open-drain drivers, it may also be used in applications where push-pull drivers are connected to the ports, however the NXB0108-Q100 may be more suitable.

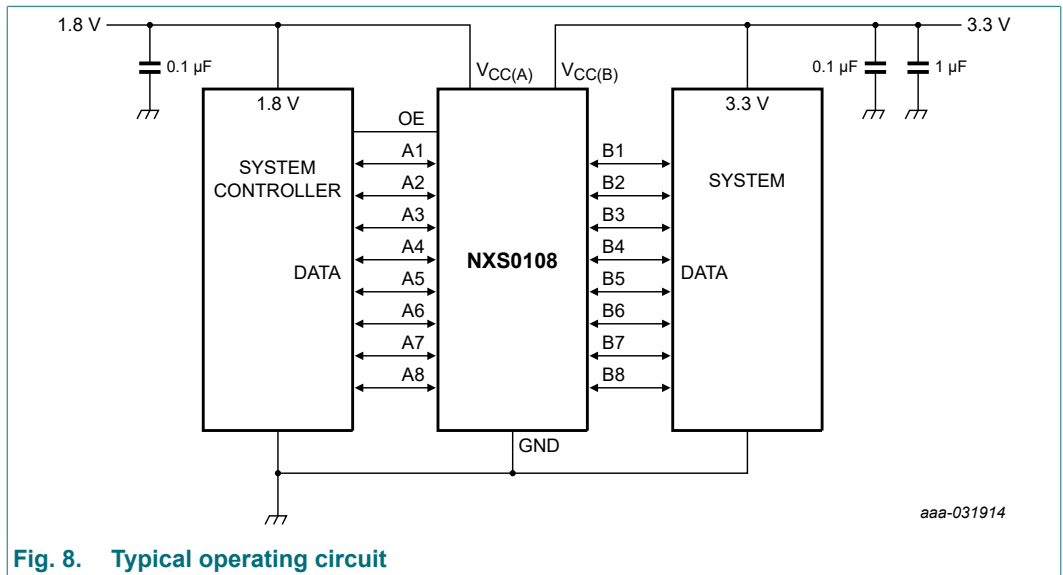

Fig. 8. Typical operating circuit

11.2. Architecture

The architecture of the NXS0108-Q100 is shown in Fig. 9. The device does not require an extra input signal to control the direction of data flow from A to B or B to A.

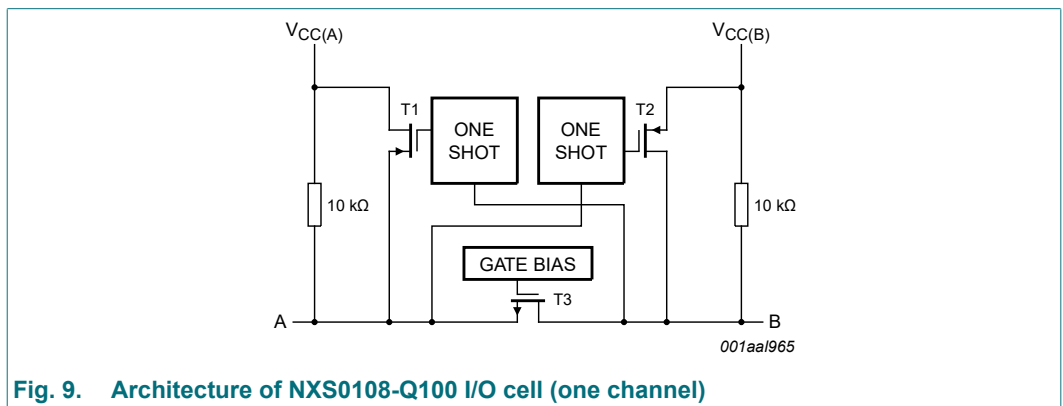

Fig. 9. Architecture of NXS0108-Q100 I/O cell (one channel)

The NXS0108-Q100 is a "switch" type voltage translator, it employs two key circuits to enable voltage translation:

1. A pass-gate transistor (N-channel) that ties the ports together.
2. An output edge-rate accelerator that detects and accelerates rising edges on the I/O pins.

The gate bias voltage of the pass gate transistor (T3) is set at approximately one threshold voltage above the V_{CC} level of the low-voltage side. During a LOW-to-HIGH transition the output one-shot accelerates the output transition by switching on the PMOS transistors (T1, T2) bypassing the 10 kΩ pull-up resistors and increasing current drive capability. The one-shot is activated once the input transition reaches approximately V_{CC}/2; it is de-activated approximately 50 ns after the output

Dual supply translating transceiver; open drain; auto direction sensing

reaches $V_{CC0}/2$. During the acceleration time the driver output resistance is between approximately $50\ \Omega$ and $70\ \Omega$. To avoid signal contention and minimize dynamic I_{CC} , the user should wait for the one-shot circuit to turn-off before applying a signal in the opposite direction. Pull-up resistors are included in the device for DC current sourcing capability.

11.3. Input driver requirements

As the NXS0108-Q100 is a switch type translator, properties of the input driver directly effect the output signal. The external open-drain or push-pull driver applied to an I/O determines the static current sinking capability of the system; the max data rate, HIGH-to-LOW output transition time (t_{THL}) and propagation delay (t_{PHL}) are dependent upon the output impedance and edge-rate of the external driver. The limits provided for these parameters in the datasheet assume a driver with output impedance below $50\ \Omega$ is used.

11.4. Output load considerations

The maximum lumped capacitive load that can be driven is dependant upon the one-shot pulse duration. In cases with very heavy capacitive loading there is a risk that the output will not reach the positive rail within the one-shot pulse duration. To avoid excessive capacitive loading and to ensure correct triggering of the one-shot it's recommended to use short trace lengths and low capacitance connectors on NXS0108-Q100 PCB layouts. To ensure low impedance termination and avoid output signal oscillations and one-shot re-triggering, the length of the PCB trace should be such that the round trip delay of any reflection is within the one-shot pulse duration (approximately $50\ \text{ns}$).

11.5. Power up

During operation $V_{CC(A)}$ must never be higher than $V_{CC(B)}$, however during power-up $V_{CC(A)} \geq V_{CC(B)}$ does not damage the device, so either power supply can be ramped up first. There is no special power-up sequencing required. The NXS0108-Q100 includes circuitry that disables all output ports when either $V_{CC(A)}$ or $V_{CC(B)}$ is switched off.

11.6. Enable and disable

An output enable input (OE) is used to disable the device. Setting OE = LOW causes all I/Os to assume the high-impedance OFF-state. The disable time (t_{dis} with no external load) indicates the delay between when OE goes LOW and when outputs actually become disabled. The enable time (t_{en}) indicates the amount of time the user must allow for one one-shot circuitry to become operational after OE is taken HIGH. To ensure the high-impedance OFF-state during power-up or power-down, pin OE should be tied to GND through a pull-down resistor, the minimum value of the resistor is determined by the current-sourcing capability of the driver.

11.7. Pull-up or pull-down resistors on I/O lines

The NXS0108-Q100 has the pull-up resistors dynamically change value based on whether a low or a high is being passed through the I/O line. Each A-port I/O has a pull-up resistor (R_{PUA}) to V_{CCA} and each B-port I/O has a pull-up resistor (R_{PUB}) to V_{CCB} . R_{PUA} and R_{PUB} have a value of $40\ \text{k}\Omega$ when the output is driving LOW. R_{PUA} and R_{PUB} have a value of $4\ \text{k}\Omega$ when the output is driving HIGH. R_{PUA} and R_{PUB} are disabled when OE = LOW. This feature provides lower static power consumption (when the I/Os are passing a LOW) and supports lower V_{OL} values for the same size pass-gate transistor and helps improve simultaneous switching performance.

12. Package outline

TSSOP20: plastic thin shrink small outline package; 20 leads; body width 4.4 mm

SOT360-1

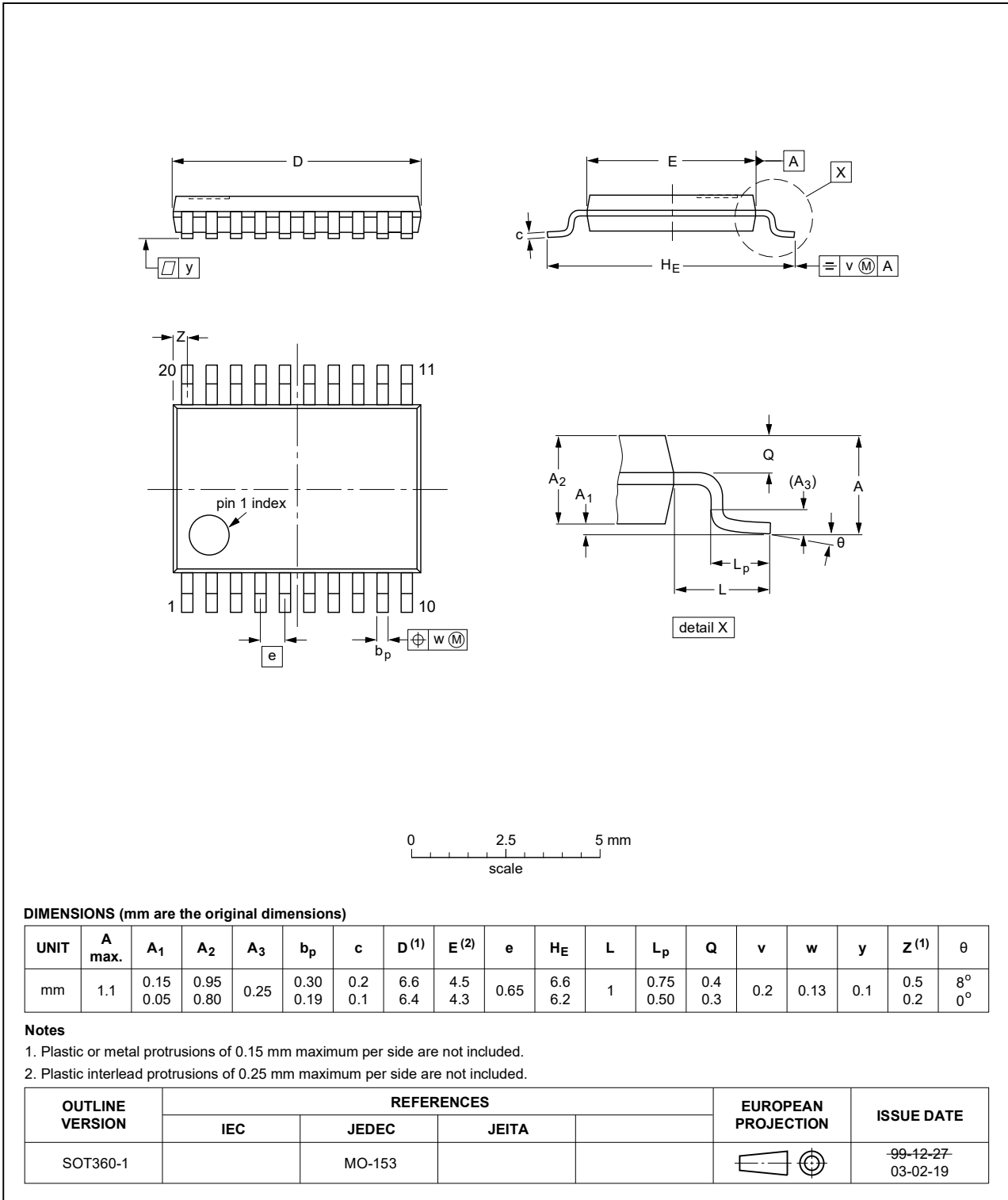

Fig. 10. Package outline SOT360-1 (TSSOP20)

Dual supply translating transceiver; open drain; auto direction sensing

DHVQFN20: plastic dual in-line compatible thermal enhanced very thin quad flat package; no leads; 20 terminals; body 2.5 x 4.5 x 0.85 mm

SOT764-1

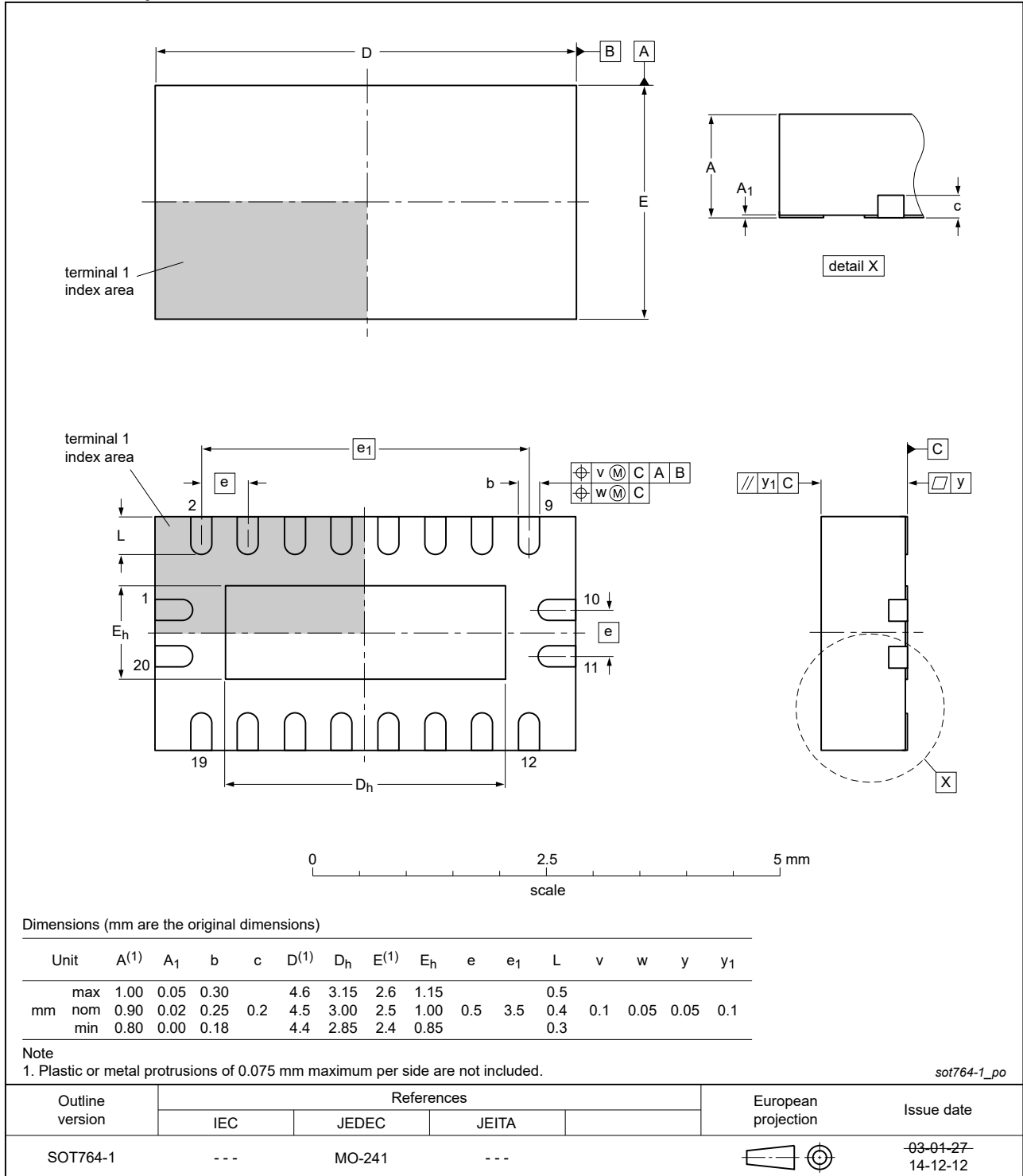

Fig. 11. Package outline SOT764-1 (DHVQFN20)

13. Abbreviations

Table 15. Abbreviations

| Acronym | Description |
|------------------|---|
| CDM | Charged Device Model |
| CMOS | Complementary Metal Oxide Semiconductor |
| DUT | Device Under Test |
| ESD | ElectroStatic Discharge |
| HBM | Human Body Model |
| I ² C | Inter-Integrated Circuit |
| MM | Machine Model |
| SMBus | System Management Bus |

14. Revision history

Table 16. Revision history

| Document ID | Release date | Data sheet status | Change notice | Supersedes |
|------------------|--------------|--------------------|---------------|------------|
| NXS0108_Q100 v.1 | 20200915 | Product data sheet | - | - |

15. Legal information

Data sheet status

| Document status [1][2] | Product status [3] | Definition |
|--------------------------------|--------------------|---|
| Objective [short] data sheet | Development | This document contains data from the objective specification for product development. |
| Preliminary [short] data sheet | Qualification | This document contains data from the preliminary specification. |
| Product [short] data sheet | Production | This document contains the product specification. |

- [1] Please consult the most recently issued document before initiating or completing a design.
- [2] The term 'short data sheet' is explained in section "Definitions".
- [3] The product status of device(s) described in this document may have changed since this document was published and may differ in case of multiple devices. The latest product status information is available on the internet at <https://www.nexperia.com>.

Definitions

Draft — The document is a draft version only. The content is still under internal review and subject to formal approval, which may result in modifications or additions. Nexperia does not give any representations or warranties as to the accuracy or completeness of information included herein and shall have no liability for the consequences of use of such information.

Short data sheet — A short data sheet is an extract from a full data sheet with the same product type number(s) and title. A short data sheet is intended for quick reference only and should not be relied upon to contain detailed and full information. For detailed and full information see the relevant full data sheet, which is available on request via the local Nexperia sales office. In case of any inconsistency or conflict with the short data sheet, the full data sheet shall prevail.

Product specification — The information and data provided in a Product data sheet shall define the specification of the product as agreed between Nexperia and its customer, unless Nexperia and customer have explicitly agreed otherwise in writing. In no event however, shall an agreement be valid in which the Nexperia product is deemed to offer functions and qualities beyond those described in the Product data sheet.

Disclaimers

Limited warranty and liability — Information in this document is believed to be accurate and reliable. However, Nexperia does not give any representations or warranties, expressed or implied, as to the accuracy or completeness of such information and shall have no liability for the consequences of use of such information. Nexperia takes no responsibility for the content in this document if provided by an information source outside of Nexperia.

In no event shall Nexperia be liable for any indirect, incidental, punitive, special or consequential damages (including - without limitation - lost profits, lost savings, business interruption, costs related to the removal or replacement of any products or rework charges) whether or not such damages are based on tort (including negligence), warranty, breach of contract or any other legal theory.

Notwithstanding any damages that customer might incur for any reason whatsoever, Nexperia's aggregate and cumulative liability towards customer for the products described herein shall be limited in accordance with the Terms and conditions of commercial sale of Nexperia.

Right to make changes — Nexperia reserves the right to make changes to information published in this document, including without limitation specifications and product descriptions, at any time and without notice. This document supersedes and replaces all information supplied prior to the publication hereof.

Suitability for use in automotive applications — This Nexperia product has been qualified for use in automotive applications. Unless otherwise agreed in writing, the product is not designed, authorized or warranted to be suitable for use in life support, life-critical or safety-critical systems or

equipment, nor in applications where failure or malfunction of an Nexperia product can reasonably be expected to result in personal injury, death or severe property or environmental damage. Nexperia and its suppliers accept no liability for inclusion and/or use of Nexperia products in such equipment or applications and therefore such inclusion and/or use is at the customer's own risk.

Quick reference data — The Quick reference data is an extract of the product data given in the Limiting values and Characteristics sections of this document, and as such is not complete, exhaustive or legally binding.

Applications — Applications that are described herein for any of these products are for illustrative purposes only. Nexperia makes no representation or warranty that such applications will be suitable for the specified use without further testing or modification.

Customers are responsible for the design and operation of their applications and products using Nexperia products, and Nexperia accepts no liability for any assistance with applications or customer product design. It is customer's sole responsibility to determine whether the Nexperia product is suitable and fit for the customer's applications and products planned, as well as for the planned application and use of customer's third party customer(s). Customers should provide appropriate design and operating safeguards to minimize the risks associated with their applications and products.

Nexperia does not accept any liability related to any default, damage, costs or problem which is based on any weakness or default in the customer's applications or products, or the application or use by customer's third party customer(s). Customer is responsible for doing all necessary testing for the customer's applications and products using Nexperia products in order to avoid a default of the applications and the products or of the application or use by customer's third party customer(s). Nexperia does not accept any liability in this respect.

Limiting values — Stress above one or more limiting values (as defined in the Absolute Maximum Ratings System of IEC 60134) will cause permanent damage to the device. Limiting values are stress ratings only and (proper) operation of the device at these or any other conditions above those given in the Recommended operating conditions section (if present) or the Characteristics sections of this document is not warranted. Constant or repeated exposure to limiting values will permanently and irreversibly affect the quality and reliability of the device.

Terms and conditions of commercial sale — Nexperia products are sold subject to the general terms and conditions of commercial sale, as published at <http://www.nexperia.com/profile/terms>, unless otherwise agreed in a valid written individual agreement. In case an individual agreement is concluded only the terms and conditions of the respective agreement shall apply. Nexperia hereby expressly objects to applying the customer's general terms and conditions with regard to the purchase of Nexperia products by customer.

No offer to sell or license — Nothing in this document may be interpreted or construed as an offer to sell products that is open for acceptance or the grant, conveyance or implication of any license under any copyrights, patents or other industrial or intellectual property rights.

Export control — This document as well as the item(s) described herein may be subject to export control regulations. Export might require a prior authorization from competent authorities.

Translations — A non-English (translated) version of a document is for reference only. The English version shall prevail in case of any discrepancy between the translated and English versions.

Trademarks

Notice: All referenced brands, product names, service names and trademarks are the property of their respective owners.

Contents

| | |
|--|-----------|
| 1. General description | 1 |
| 2. Features and benefits | 1 |
| 3. Ordering information | 1 |
| 4. Functional diagram | 2 |
| 5. Pinning information | 2 |
| 5.1. Pinning..... | 2 |
| 5.2. Pin description..... | 3 |
| 6. Functional description | 3 |
| 7. Limiting values | 3 |
| 8. Recommended operating conditions | 4 |
| 9. Static characteristics | 5 |
| 10. Dynamic characteristics | 8 |
| 10.1. Waveforms and test circuit..... | 16 |
| 11. Application information | 19 |
| 11.1. Voltage level-translation applications..... | 19 |
| 11.2. Architecture..... | 19 |
| 11.3. Input driver requirements..... | 20 |
| 11.4. Output load considerations..... | 20 |
| 11.5. Power up..... | 20 |
| 11.6. Enable and disable..... | 20 |
| 11.7. Pull-up or pull-down resistors on I/O lines..... | 20 |
| 12. Package outline | 21 |
| 13. Abbreviations | 23 |
| 14. Revision history | 23 |
| 15. Legal information | 24 |

© Nexperia B.V. 2020. All rights reserved

For more information, please visit: <http://www.nexperia.com>
 For sales office addresses, please send an email to: salesaddresses@nexperia.com
 Date of release: 15 September 2020