



AK4528

High Performance 24Bit 96kHz Audio CODEC

GENERAL DESCRIPTION

The AK4528 is a high performance 24bit CODEC for the 96kHz recording system. The ADC has an Enhanced Dual Bit architecture with wide dynamic range. The DAC uses the new developed Advanced Multi Bit architecture and achieves low out-band noise and high jitter tolerance by use of SCF (switched capacitor filter) techniques.

FEATURES

- **24bit 2ch ADC**
 - 64x Oversampling
 - Full differential Inputs
 - S/(N+D): 94dB
 - Dynamic Range, S/N: 108dB
 - Digital HPF for offset cancellation
 - I/F format: MSB justified or I²S
- **24bit 2ch DAC**
 - 128x Oversampling
 - 24bit 8 times Digital Filter
 - Ripple: ± 0.005 dB, Attenuation: 75dB
 - SCF
 - Differential Outputs
 - S/(N+D): 94dB
 - Dynamic Range, S/N: 110dB
 - De-emphasis for 32kHz, 44.1kHz and 48kHz sampling
 - Output DATT with -72dB att
 - Soft Mute
 - I/F format: MSB justified, LSB justified or I²S
- **High Jitter Tolerance**
- **3-wire Serial Interface for Volume Control**
- **Master Clock**
 - 256fs/384fs/512fs/768fs/1024fs
- **5V operation**
- **3V Power Supply Pin for 3V I/F**
- **Small 28pin SSOP package**

■ Block Diagram

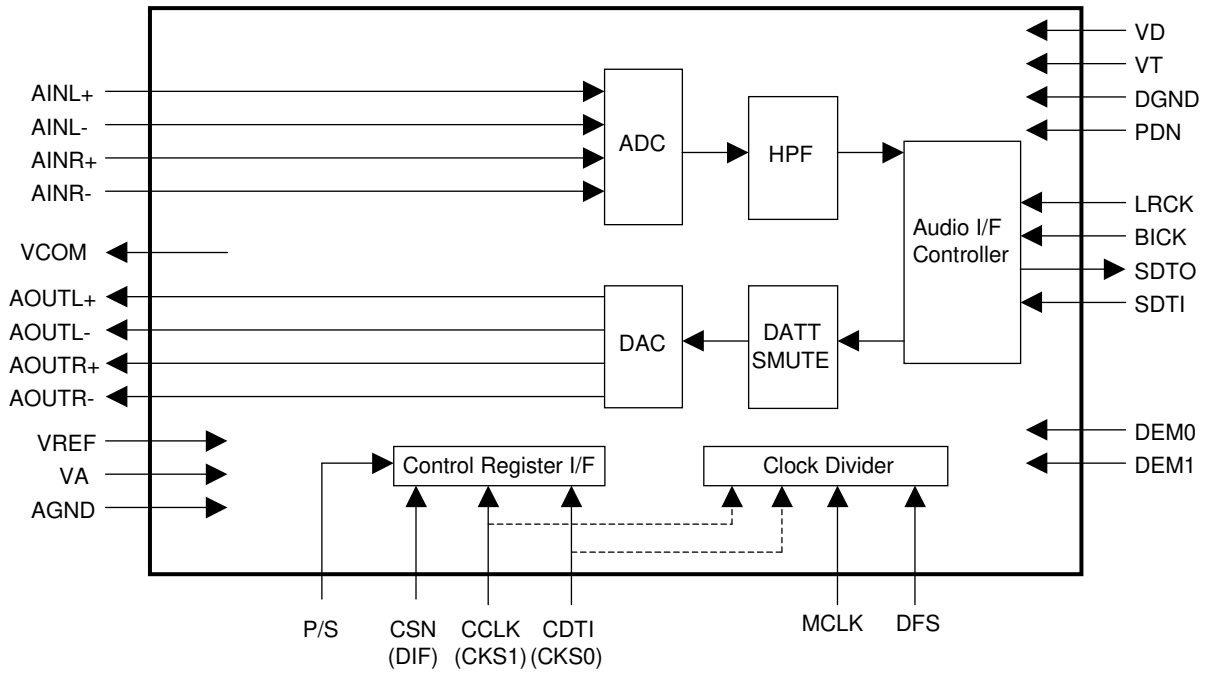

Block Diagram

● Compatibility of AK4528 with AK4524

Function	AK4528	AK4524
ADC S/(N+D)	94dB	90dB
ADC DR, S/N	108dB	100dB
Input PGA & ATT	X	O
ADC Inputs	Differential Inputs	Single-end Inputs
Master Mode	X	O
X'tal Oscillating Circuit	X	O
Quad Speed Mode	X	O
Parallel Mode	O	X

O: Available, X: Not Available

■ Ordering Guide

AK4528VM

-40 ~ +85°C

28pin SSOP (0.65mm pitch)

■ Pin Layout

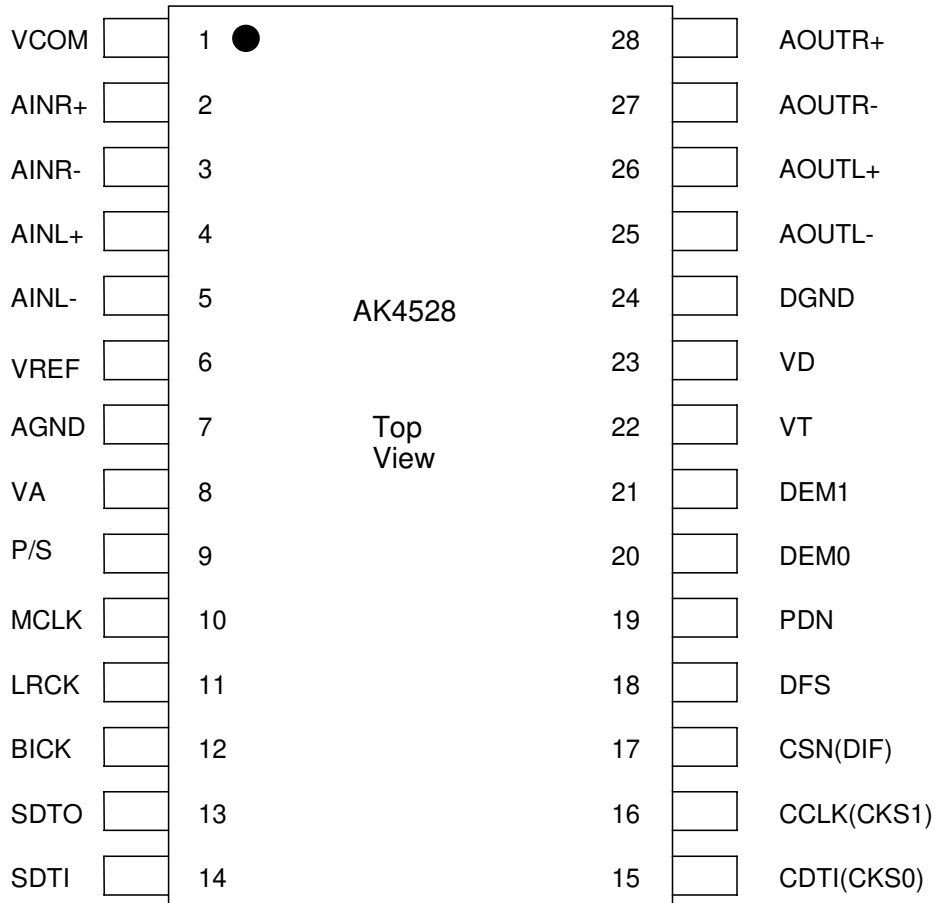

PIN/FUNCTION			
No.	Pin Name	I/O	Function
1	VCOM	O	Common Voltage Output Pin, VA/2 Bias voltage of ADC inputs and DAC outputs.
2	AINR+	I	Rch Positive Input Pin
3	AINR-	I	Rch Negative Input Pin
4	AINL+	I	Lch Positive Input Pin
5	AINL-	I	Lch Negative Input Pin
6	VREF	I	Voltage Reference Input Pin, VA Used as a voltage reference by ADC & DAC. VREF is connected externally to filtered VA.
7	AGND	-	Analog Ground Pin
8	VA	-	Analog Power Supply Pin, 4.75 ~ 5.25V
9	P/S	I	Parallel/Serial Mode Select Pin “L”: Serial Mode, “H”: Parallel Mode
10	MCLK	I	Master Clock Input Pin
11	LRCK	I	Input/Output Channel Clock Pin
12	BICK	I	Audio Serial Data Clock Pin
13	SDTO	O	Audio Serial Data Output Pin
14	SDTI	I	Audio Serial Data Input Pin
15	CDTI	I	Control Data Input Pin in Serial Mode
	CKS0	I	Master Clock Select Pin
16	CCLK	I	Control Data Clock Pin in Serial Mode
	CKS1	I	Master Clock Select Pin
17	CSN	I	Chip Select Pin in Serial Mode
	DIF	I	Digital Audio Interface Select Pin “L”: 24bit MSB justified, “H”: I ² S compatible
18	DFS	I	Double Speed Sampling Mode Pin
19	PDN	I	Power-Down Mode Pin “H”: Power up, “L”: Power down reset and initialize the control register.
20	DEMO	I	De-emphasis Control Pin
21	DEM1	I	De-emphasis Control Pin
22	VT	-	Output Buffer Power Supply Pin, 2.7 ~ 5.25V
23	VD	-	Digital Power Supply Pin, 4.75 ~ 5.25V
24	DGND	-	Digital Ground Pin
25	AOUTL-	O	Lch Negative Analog Output Pin
26	AOUTL+	O	Lch Positive Analog Output Pin
27	AOUTR-	O	Rch Negative Analog Output Pin
28	AOUTR+	O	Rch Positive Analog Output Pin

Note: All input pins should not be left floating.

ABSOLUTE MAXIMUM RATINGS

(AGND=DGND=0V; Note 1)

Parameter		Symbol	min	max	Unit
Power Supplies:	Analog	VA	-0.3	6.0	V
	Digital	VD	-0.3	6.0	V
	Output Buffer	VT	-0.3	6.0	V
	VD-VA	VDA	-	0.3	V
Input Current, Any Pin Except Supplies		IIN	-	±10	mA
Analog Input Voltage		VINA	-0.3	VA+0.3	V
Digital Input Voltage		VIND	-0.3	VA+0.3	V
Ambient Temperature (powered applied)		Ta	-40	85	°C
Storage Temperature		Tstg	-65	150	°C

Note: 1. All voltages with respect to ground.

WARNING: Operation at or beyond these limits may result in permanent damage to the device.
Normal operation is not guaranteed at these extremes.

RECOMMENDED OPERATING CONDITIONS

(AGND= DGND=0V; Note 1)

Parameter		Symbol	min	typ	max	Unit
Power Supplies	Analog	VA	4.75	5.0	5.25	V
	Digital	VD	4.75	5.0	VA	V
	Output Buffer	VT	2.7	3.0	VD	V
Voltage Reference		VREF	3.0	-	VA	V

Note: 1. All voltages with respect to ground.

2. VA and VD should be powered at the same time or VA should be powered earlier than VD.
The power up sequence between VA and VT, or VD and VT is not critical.

*AKM assumes no responsibility for the usage beyond the conditions in this datasheet.

ANALOG CHARACTERISTICS

(Ta=25°C; VA=VD=VT=5.0V; AGND=DGND=0V; VREF=VA; fs=44.1kHz; Signal Frequency = 1kHz; 24bit Data; Measurement frequency = 20Hz ~ 20kHz at fs=44.1kHz, 40Hz ~ 40kHz at fs=96kHz; unless otherwise specified)

Parameter		min	typ	max	Unit
Input PGA Characteristics:					
ADC Analog Input Characteristics: Analog Source impedance = 330Ω					
Resolution				24	Bits
Input Voltage	(Note 3)	±2.6	±2.8	±3.0	Vpp
Input Resistance	fs=44.1kHz	16	27		kΩ
	fs=96kHz	7	12		kΩ
S/(N+D) (-0.5dBFS)	fs=44.1kHz	88	94		dB
	fs=96kHz	84	92		dB
DR (-60dBFS)	fs=44.1kHz, A-weighted	100	108		dB
	fs=96kHz	95	103		dB
S/N	fs=44.1kHz, A-weighted	100	108		dB
	fs=96kHz	95	103		dB
Interchannel Isolation		90	110		dB
Interchannel Gain Mismatch			0.2	0.5	dB
Gain Drift			20	-	ppm/°C
Input Voltage	(Note 3)	±2.6	±2.8	±3.0	Vpp
Input Resistance	fs=44.1kHz	16	27		kΩ
	fs=96kHz	7	12		kΩ
Input DC Bias Voltage	(Note 4)	0.56VA	-	0.60VA	V
Power Supply Rejection	(Note 5)	-	50	-	dB
DAC Analog Output Characteristics:					
Resolution				24	Bits
S/(N+D) (0dBFS)	fs=44.1kHz	88	94		dB
	fs=96kHz	85	93		dB
DR (-60dBFS)	fs=44.1kHz, A-weighted	104	110		dB
	fs=96kHz	96	104		dB
S/N	fs=44.1kHz, A-weighted	104	110		dB
	fs=96kHz	96	104		dB
Interchannel Isolation		90	110		dB
Interchannel Gain Mismatch			0.2	0.5	dB
Gain Drift			20	-	ppm/°C
Output Voltage	(Note 6)	5.0	5.4	5.8	Vpp
Load Resistance	(In case of AC load)	1			kΩ
Output Current				1.5	mA
Load Capacitance				25	pF
Power Supply Rejection	(Note 5)		50	-	dB

Note: 3. This voltage is input to AIN+ and AIN- pin, and is proportional to VREF. $V_{in} = 0.56 \times VREF$.

4. Measured by Figure 12. DC Bias Voltage, $V_b = 4.7k / (3.3k + 4.7k) \times VA = 0.5875VA$.

5. PSR is applied to VA, VD, VT with 1kHz, 50mVpp. VREF pin is held a constant voltage.

6. Full scale (0dB) of the output voltage when summing the differential outputs, AOUT+/- by unity gain.
This voltage is proportional to VREF. $V_{out} = 1.08 \times VREF \times \text{Gain}$.

DC CHARACTERISTICS

(Ta=25°C; VA=VD=4.75 ~ 5.25V; VT=2.7 ~ 5.25V)

Parameter	Symbol	min	typ	max	Unit
High-Level Input Voltage	VIH	2.2	-	-	V
Low-Level Input Voltage	VIL	-	-	0.8	V
High-Level Output Voltage (Iout=-100μA) (Note 11)	VOH	2.7 / VT-0.5	-	-	V
Low-Level Output Voltage (Iout=100μA)	VOL	-	-	0.5	V
Input Leakage Current	Iin	-	-	±10	μA

Note: 11. The min value is lower voltage of 2.7V or VT-0.5V.

SWITCHING CHARACTERISTICS

(Ta=25°C; VA=VD=4.75 ~ 5.25V; VT=2.7 ~ 5.25V; CL=20pF)

Parameter	Symbol	min	typ	max	Unit
Master Clock Timing					
Frequency	fCLK	7.68		55.296	MHz
Pulse Width Low	tCLKL	0.4/fCLK			ns
Pulse Width High	tCLKH	0.4/fCLK			ns
LRCK Frequency					
Normal Speed Mode (DFS = "0")	fsn	30	44.1	54	kHz
Double Speed Mode (DFS = "1")	fsd	60	88.2	108	kHz
Duty Cycle	Duty	45		55	%
Audio Interface Timing					
BICK Period	tBCK	81			ns
BICK Pulse Width Low	tBCKL	33			ns
Pulse Width High	tBCKH	33			ns
LRCK Edge to BICK "↑" (Note 12)	tLRB	20			ns
BICK "↑" to LRCK Edge (Note 12)	tBLR	20			ns
LRCK to SDTO (MSB) (Except I ² S mode)	tLRS			40	ns
BICK "↓" to SDTO	tBSD			40	ns
SDTI Hold Time	tSDH	20			ns
SDTI Setup Time	tSDS	20			ns

Note 12. BICK rising edge must not occur at the same time as LRCK edge.

Parameter	Symbol	min	typ	max	Unit
Control Interface Timing (P/S="L")					
CCLK Period	tCCK	200			ns
CCLK Pulse Width Low	tCCKL	80			ns
Pulse Width High	tCCKH	80			ns
CDTI Setup Time	tCDS	40			ns
CDTI Hold Time	tCDH	40			ns
CSN "H" Time	tCSW	150			ns
CSN "L" Time	tCSW	150			ns
CSN "↑" to CCLK "↑"	tCSS	150			ns
CCLK "↑" to CSN "↑"	tCSH	50			ns
Reset Timing					
PDN Pulse Width (Note 13)	tPD	150			ns
RSTADN "↑" to SDTO valid (Note 14)	tPDV		516		1/fs
PDN "↑" to SDTO valid (Note 15)	tPDV		516		1/fs

Note: 13. The AK4528 can be reset by bringing PDN "L".

14. In serial mode, these cycles are the number of LRCK rising from RSTADN bit.

15. In parallel mode, these cycles are the number of LRCK rising from PDN pin.

■ Timing Diagram

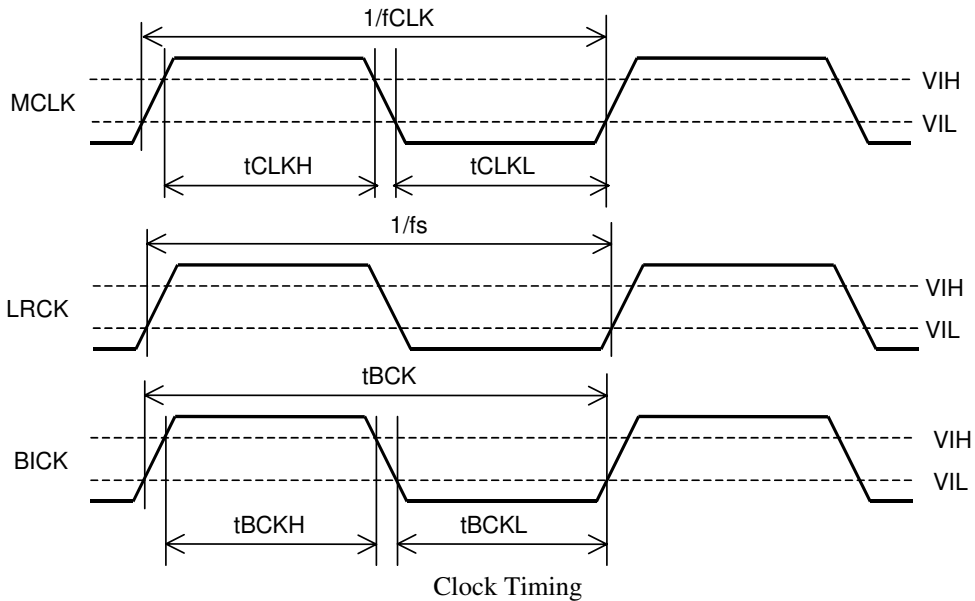

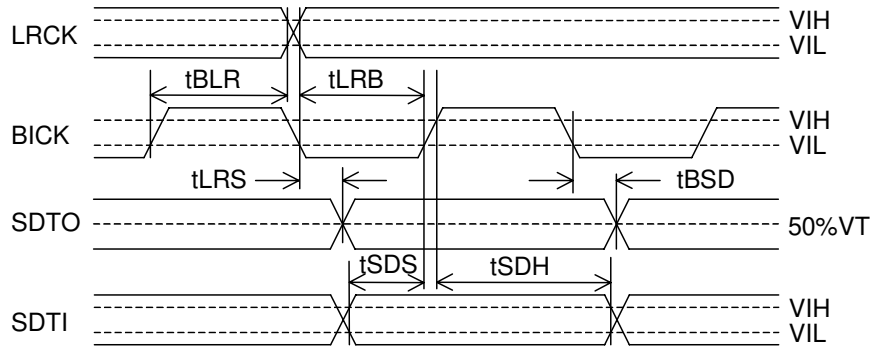

Audio Interface Timing

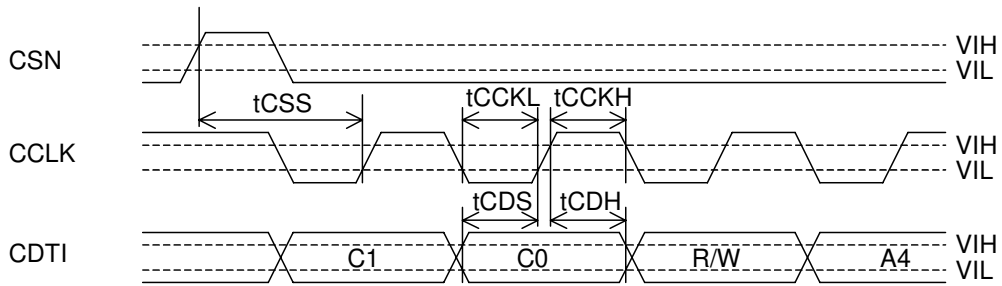

WRITE Command Input Timing

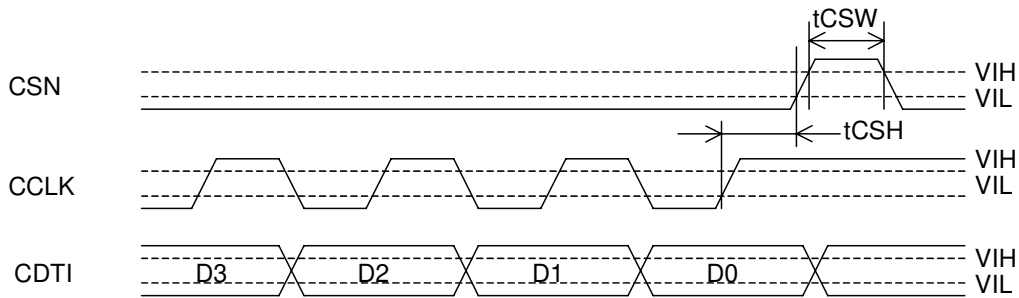

WRITE Data Input Timing

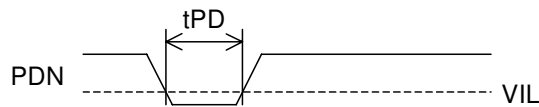

Power Down & Reset Timing

OPERATION OVERVIEW

■ System Clock Input

The external clocks, which are required to AK4528, are MCLK, BICK and LRCK. MCLK should be synchronized with LRCK but the phase is not critical. The frequency of MCLK is set by CMODE, CKS0-1 and DFS bits in serial mode, or by CKS0-1, DFS pins in parallel mode (see Table 2 and 3). The CKS0-1 and DFS pin should be changed during the PDN pin = "L". The CMODE, CKS0-1 and DFS bits are changed during RSTADN = RSTDAN = "0".

External clocks (MCLK, BICK and LRCK) should always be present whenever the AK4528 is in normal operation mode (PDN = "H" and at least one of ADC and DAC is in normal operation mode). If these clocks are not provided, the AK4528 may draw excess current because the device utilizes dynamic refreshed logic internally. If the external clocks are not present, the AK4528 should be in the power-down mode (PDN = "L" or set both ADC and DAC power down mode by the register).

CMODE bit	CKS1 bit	CKS0 bit	MCLK Normal Speed (DFS bit = "0")	MCLK Double Speed (DFS bit = "1")	Default
0	0	0	256fs	N/A	
0	0	1	512fs	256fs	
0	1	0	1024fs	512fs	
1	0	0	384fs	N/A	
1	0	1	768fs	384fs	

Table 1. Master Clock Frequency Select in Serial Mode

CKS1 pin	CKS0 pin	MCLK Normal Speed (DFS pin = "L")	MCLK Double Speed (DFS pin = "H")
L	L	256fs	N/A
L	H	512fs	256fs
H	L	384fs	N/A
H	H	1024fs	512fs

Table 2. Master Clock Frequency Select in Parallel Mode

MCLK Normal Speed (DFS = "0")	fs=44.1kHz	fs=48kHz	MCLK Double Speed (DFS = "1")	fs=88.2kHz	fs=96kHz
256fs	11.2896MHz	12.288MHz	N/A	N/A	N/A
512fs	22.5792MHz	24.576MHz	256fs	22.5792MHz	24.576MHz
1024fs	45.1584MHz	49.152MHz	512fs	45.1584MHz	49.152MHz
384fs	16.9344MHz	18.432MHz	N/A	N/A	N/A
768fs	33.8688MHz	36.864MHz	384fs	33.8688MHz	36.864MHz

Table 3. Master Clock Frequencies example

Note. Do not set any mode which is not described in Table1-3.

■ Audio Serial Interface Format

In case of serial mode, the DIF0-2 bits as shown in Table 4 support five serial formats. In case of parallel mode, two formats (Mode 2 and 3) are supported by DIF pin (Table 5). In all modes the serial data is MSB-first, 2's compliment format. The SDTO is clocked out on the falling edge of BICK and the SDTI is latched on the rising edge.

Mode	DIF2 bit	DIF1 bit	DIF0 bit	SDTO	SDTI	LRCK	BICK
0	0	0	0	24bit, MSB justified	16bit, LSB justified	H/L	≥ 32fs
1	0	0	1	24bit, MSB justified	20bit, LSB justified	H/L	≥ 40fs
2	0	1	0	24bit, MSB justified	24bit, MSB justified	H/L	≥ 48fs
3	0	1	1	24bit, I ² S	24bit, I ² S	L/H	≥ 48fs
4	1	0	0	24bit, MSB justified	24bit, LSB justified	H/L	≥ 48fs

Default
t

Table 4. Audio data format in Serial Mode

Mode	DIF pin	SDTO	SDTI	LRCK	BICK
2	0	24bit, MSB justified	24bit, MSB justified	H/L	≥ 48fs
3	1	24bit, I ² S	24bit, I ² S	L/H	≥ 48fs

Table 5. Audio data format in Parallel Mode

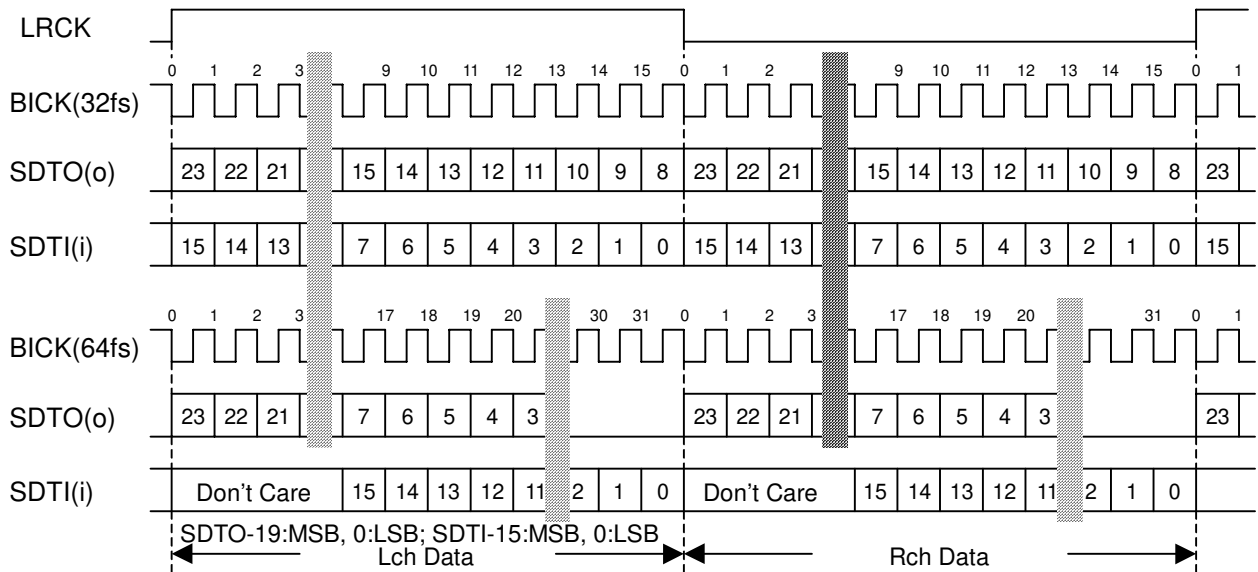

Figure 1. Mode 0 Timing

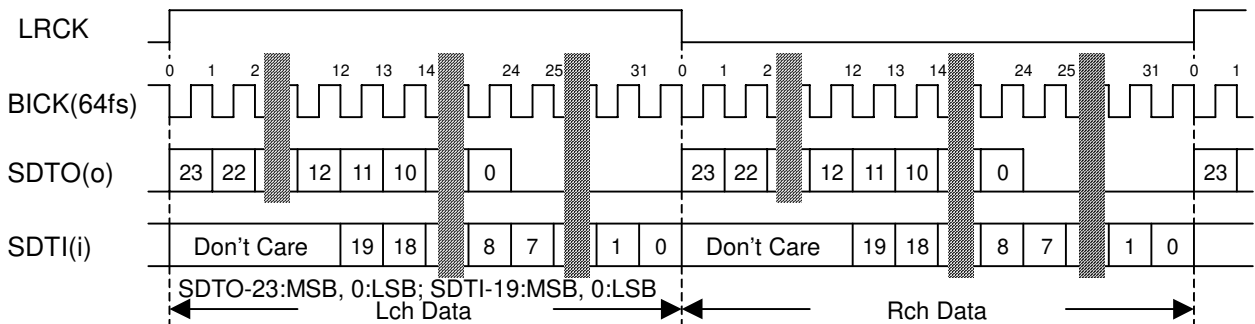

Figure 2. Mode 1 Timing

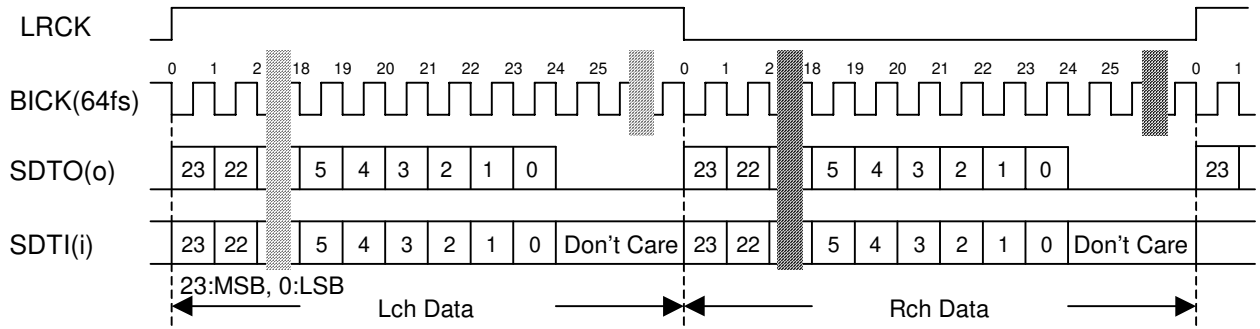

Figure 3. Mode 2 Timing

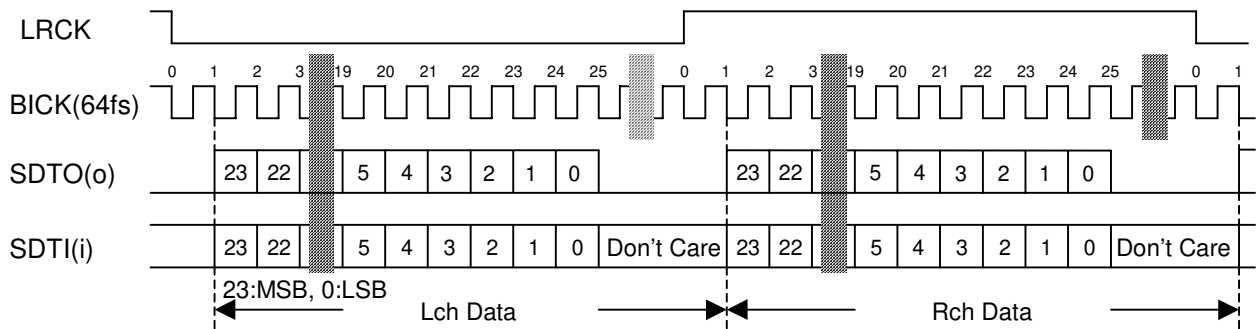

Figure 4. Mode 3 Timing

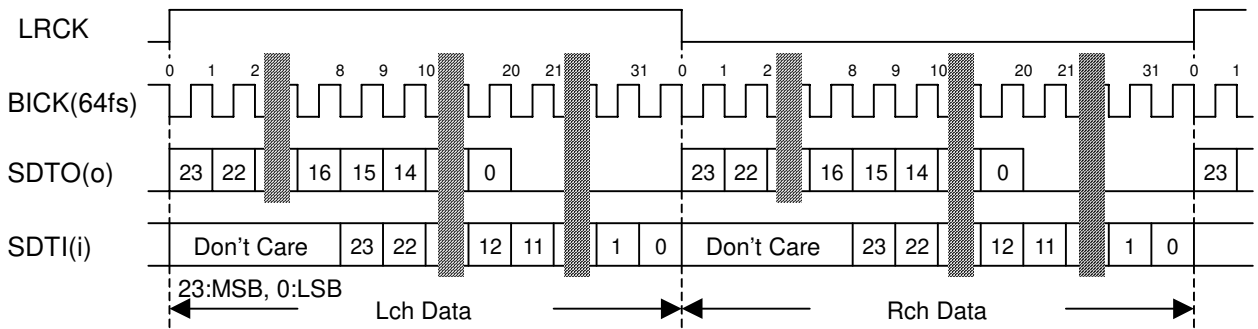

Figure 5. Mode 4 Timing

■ Parallel/Serial Mode Control

When P/S= “H”, AK4528 is in parallel mode. The audio interface format is selected by DIF pin, and DFS and CK0-1 pins select the frequency of MCLK.

When P/S= “L”, AK4528 is in serial mode. The CKS1, CKS0 and DIF pins are changed to CDTI, CCLK and CSN pins respectively. The DEM0-1 and DFS are ORed between pin and register respectively, so those are able to control by pins even in serial mode. To control all the functions by register, set DEM0-1 and DFS pins “L”.

■ Digital High Pass Filter

The ADC has a digital high pass filter (HPF) for DC offset cancel. The cut-off frequency of the HPF is 0.9Hz at $f_s=44.1\text{kHz}$ and also scales with sampling rate (f_s). This HPF can be off for each channel by register.

■ Output Volume

The AK4528 includes digital volumes (OATT) with 128 levels (including MUTE) in front of DAC. The OATT is a pseudo-log volume linear-interpolated internally. When the level is changed, the transition to new value takes 8031 levels (max) and is done by soft transition. Therefore, there is not any switching noise.

■ De-emphasis Filter

The DAC includes the digital de-emphasis filter ($t_c=50/15\mu\text{s}$) by IIR filter. This filter supports to three frequencies (32kHz, 44.1kHz and 48kHz). This setting is done by control register and always OFF at double speed mode.

No	DEM1	DEM0	Mode
0	0	0	44.1kHz
1	0	1	OFF
2	1	0	48kHz
3	1	1	32kHz

Default in serial mode

Table 6. De-emphasis control (DFS=“0”)

■ Soft Mute Operation

Soft mute operation is performed at digital domain. When SMUTE goes “1”, the output signal is attenuated by $-\infty$ during 1024 LRCK cycles. When SMUTE is returned to “0”, the mute is cancelled and the output attenuation gradually changes to 0dB during 1024 LRCK cycles. If the soft mute is cancelled within 1024 LRCK cycles after starting of the operation, the attenuation is discontinued and returned to 0dB.

Soft mute function is independent to output volume, and those two functions are cascade connected.

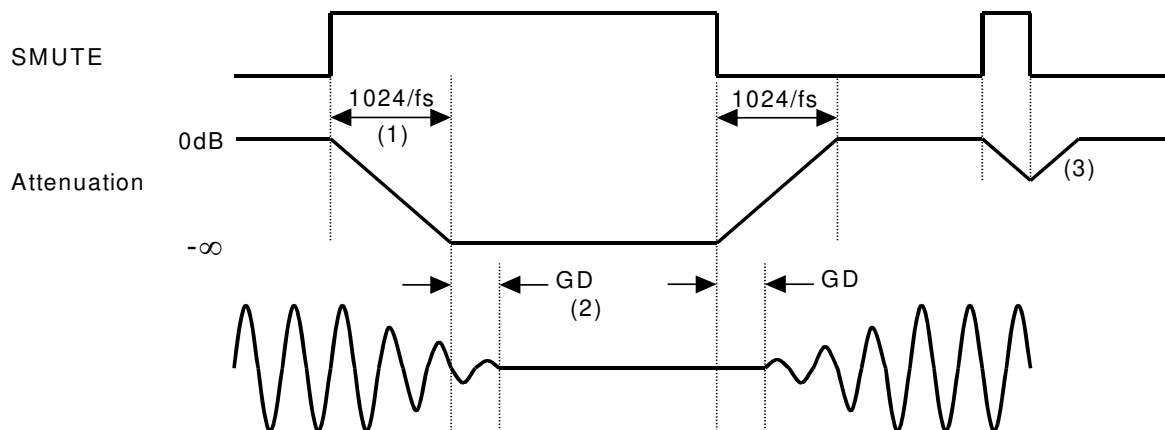

Notes:

- (1) The output signal is attenuated by $-\infty$ during 1024 LRCK cycles ($1024/f_s$).
- (2) Analog output corresponding to digital input has the group delay (GD).
- (3) If the soft mute is cancelled within 1024 LRCK cycles, the attenuation is discontinued and returned to 0dB.

Figure 6. Soft Mute

■ Power Down & Reset

The ADC and DAC of AK4528 are placed in the power-down mode by bringing a power down pin (PDN) = "L" and each digital filter is also reset at the same time. The internal register values are initialized by PDN = "L". This reset should always be done after power-up.

In case of serial mode, the default value of both control registers for ADC and DAC are in reset state (RSTADN = RSTDAN = "0"), each register should be cancelled after doing the needed setting. In case of the ADC, an analog initialization cycle starts after exiting the power-down or reset state. Therefore, the output data, SDTO becomes available after 516 cycles of LRCK. In case of DAC, the initialization cycle starts after PDN = "H" or PWVR bit = "1". The power down mode can be also controlled by the registers (PWAD, PWDA).

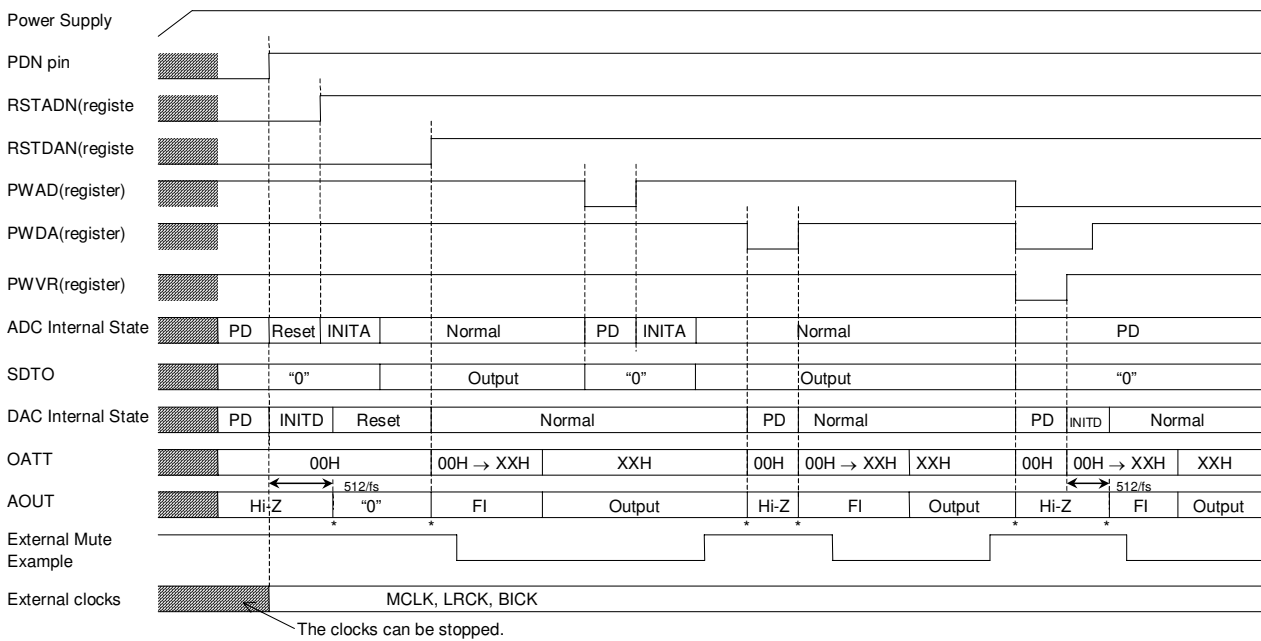

- INITA: Initializing period of ADC analog section (516/fs).
- INITD: Initializing period of DAC analog section (512/fs).
- PD: Power down state. In case of PDN = "L", the contents of all registers are initialized, otherwise hold.
- XXH: The current value in ATT register.
- FI: Fade in. After exiting power down and reset state, ATT value fades in by 8032/fs cycles (max).
- AOUT: Some pop noise may occur at "*".

Figure 7. Reset & Power down sequence in Serial Mode

In case of parallel mode, both ADC and DAC are powered up with releasing internal reset state when PDN is set to “H”. Therefore each outputs start to output at once. However the initialization of ADC/DAC, and the fade-in cycle of OATT (8031/fs) are exist.

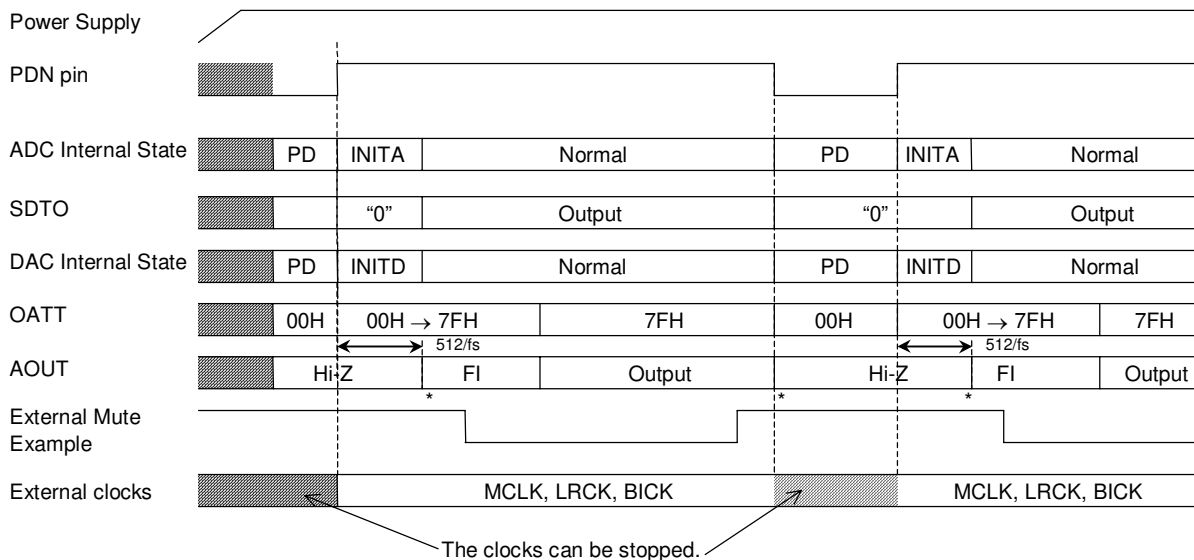

- INITA: Initializing period of ADC analog section (516/fs).
- INITD: Initializing period of DAC analog section (512/fs).
- PD: Power down state.
- FI: Fade in. After exiting power down state, ATT value fades in by 8032/fs cycles.
- AOUT: Some pop noise may occur at “*”.

Figure 8. Reset & Power Down Sequence in Parallel Mode

■ Serial Control Interface

The serial control interface is enabled by the P/S pin = “L”. The internal registers are written by the 3-wire μP interface pins: CSN, CCLK, CDTI. The data on this interface consists of Chip address (2bits, fixed to C0/1 = “01”) Read/Write (1bit, fixed to “1”), Register address (MSB first, 5bits) and Control data (MSB first, 8bits). Address and data is clocked in on the rising edge of CCLK. Data is latched after a low-to-high transition of CSN. The maximum clock speed of the CCLK is 5MHz. The CSN should be “H” if no access. The chip address is fixed to “10”. Writing is invalid for the access to the chip address except for “10”. PDN = “L” resets the registers to their default values.

Function	Parallel mode	Serial mode
Double speed	O	O
De-emphasis	O	O
SMUTE	X	O
Output Digital ATT	X	O
HPF off	X	O
MCLK; 768fs@Normal Speed 384fs@Double Speed	X	O
16/20/24bit LSB justified format	X	O

Table 7. Function list (O: available, X: not available)

When PDN = “L”, internal registers are initialized. In case of changing P/S pin, please set PDN = “L” to reset the device. In case of serial mode, the internal timings are initialized by RSTN = “0”, but the contents of registers are hold.

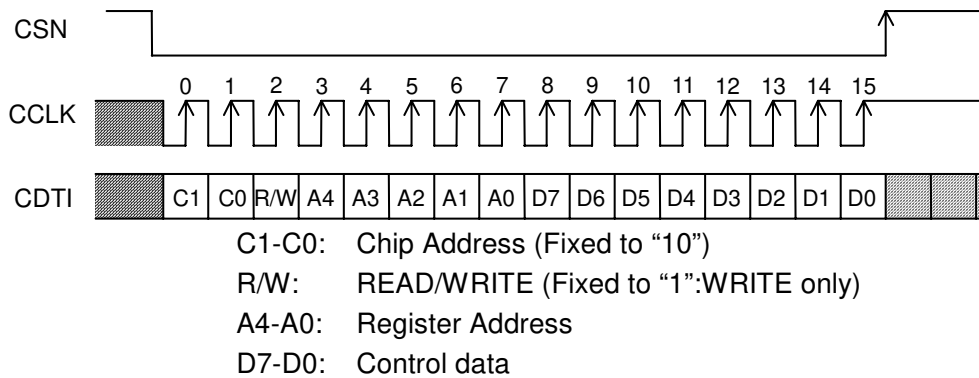

Figure 9. Control I/F Timing

*AK4528 does not support the READ. C1, C0 and R/W are fixed (“101”).

■ Register Map

Addr	Register Name	D7	D6	D5	D4	D3	D2	D1	D0
00H	Power Down Control	0	0	0	0	0	PWVR	PWAD	PWDA
01H	Reset Control	TE7	TE6	TE5	TE4	0	0	RSTADN	RSTDAN
02H	Clock and Format Control	DIF2	DIF1	DIF0	CMODE	CKS1	CKS0	0	DFS
03H	Deem and Volume Control	SMUTE	0	0	0	HPFR	HPFL	DEM1	DEM0
04H	Lch ATT Control	0	ATTL6	ATTL5	ATTL4	ATTL3	ATTL2	ATTL1	ATTL0
05H	Rch ATT Control	0	ATTR6	ATTR5	ATTR4	ATTR3	ATTR2	ATTR1	ATTR0

Note: For address from 06H to 1FH, data should not be written.

In case of writing to 01H, write "0000" to D7-4.

PDN = "L" resets the registers to their default values.

■ Control Register Setup Sequence

The setting of clock mode or data format by control register should be done during RSTADN = RSTDAN = "0", and outputs of ADC/DAC should be muted.

1. In case of using PDN pin

- (1) Set PDN= "H".
- (2) Set registers for clock mode, data format, etc.
- (3) Cancel the reset state by setting RSTADN or RSTDAN to "1". Refer to Reset Control Register (01H).

2. In case of not using PDN pin

- (1) Set RSTADN = RSTDAN = "0".
- (2) Set registers for clock mode, data format, etc.
- (3) Cancel the reset state by setting RSTADN or RSTDAN to "1". Refer to Reset Control Register (01H).

Note: Those settings may generate pop noise. Please mute the output of ADC and DAC externally.

■ Register Definitions

Addr	Register Name	D7	D6	D5	D4	D3	D2	D1	D0
00H	Power Down Control	0	0	0	0	0	PWVR	PWAD	PWDA
	default	0	0	0	0	0	1	1	1

PWDA: DAC power down

0: Power down

1: Power up

Only DAC section is powered down by “0” and then the AOUTs go Hi-Z immediately. The OATTs also go “00H”. But the contents of all register are not initialized and enabled to write to the registers.

After exiting the power down mode, the OATTs fade in the setting value of the control register (04H & 05H). The analog outputs should be muted externally as some pop noise may occur when entering to and exiting from this mode.

PWAD: ADC power down

0: Power down

1: Power up

Only ADC section is powered down by “0” and then the SDTO goes “L” immediately. The contents of all register are not initialized and enabled to write to the registers.

After exiting the power down mode, ADC outputs “0” during first 516 LRCK cycles.

PWVR: Vref power down

0: Power down

1: Power up

All sections are powered down by “0” and then both ADC and DAC do not operate. The contents of all register are not initialized and enabled to write to the registers. When PWAD and PWDA go “0” and PWVR goes “1”, only VREF section can be powered up.

Addr	Register Name	D7	D6	D5	D4	D3	D2	D1	D0
01H	Reset Control	TE7	TE6	TE5	TE4	0	0	RSTADN	RSTDAN
	default	0	0	0	0	0	0	0	0

TE7-4: Test Control Register Enable

Must be fixed to “0000”.

RSTDAN: DAC reset

0: Reset

1: Normal Operation

The internal timing is reset by “0” and then the AOUTs go VCOM voltage immediately. The OATTs also go “00H”. But the contents of all register are not initialized and enabled to write to the registers. After exiting the power down mode, the OATTs fade in the setting value of the control register (06H & 07H). The analog outputs should be muted externally as some pop noise may occur when entering to and exiting from this mode.

RSTDAN: ADC reset

0: Reset

1: Normal Operation

The internal timing is reset by “0” and then SDTO goes “L” immediately. But the contents of all register are not initialized and enabled to write to the register.

After exiting the power down mode, ADCs output “0” during first 516 LRCK cycles.

Addr	Register Name	D7	D6	D5	D4	D3	D2	D1	D0
02H	Clock and Format Control	DIF2	DIF1	DIF0	CMODE	CKS1	CKS0	0	DFS
	default	0	1	0	0	0	0	0	0

DFS: Sampling Speed Control (see Table 1 and Table 3)

Default : normal speed mode.
Ored with DFS pin internally.

CMODE, CKS1-0: Master Clock Frequency Select (see Table 1)

Default: 256fs

DIF2-0: Audio data interface modes (see Table 4)

000: Mode 0
001: Mode 1
010: Mode 2
011: Mode 3
100: Mode 4
Default : 24bit MSB justified for both ADC and DAC

Addr	Register Name	D7	D6	D5	D4	D3	D2	D1	D0
03H	Deem and Volume Control	SMUTE	0	0	0	HPFR	HPFL	DEM1	DEM0
	default	0	0	0	0	1	1	0	0

DEM1-0: De-emphasis response (see Table 6)

00: 44.1kHz
01: OFF
10: 48kHz
11: 32kHz
Default : 44.1kHz.
ORed with DEM1, DEM0 pins respectively.

HPFR: Right channel Digital High Pass Filter Control

0: Disable
1: Enable
Default : Enable

HPFL: Left channel Digital High Pass Filter Control

0: Disable
1: Enable
Default : Enable

SMUTE: DAC Input Soft Mute control

0: Normal operation
1: DAC outputs soft-muted
The soft mute is independent of the output ATT and performed digitally.

Addr	Register Name	D7	D6	D5	D4	D3	D2	D1	D0
04H	Lch OATT Control	0	ATTL6	ATTL5	ATTL4	ATTL3	ATTL2	ATTL1	ATTL0
05H	Rch OATT Control	0	ATTR6	ATTR5	ATTR4	ATTR3	ATTR2	ATTR1	ATTR0
default		0	1	1	1	1	1	1	1

ATTL/R6-0: DAC ATT Level (see Table 8)
 Default : 7FH (0dB)

The OATTs are set to “00H” when PDN pin goes “L”. After returning to “H”, the OATTs fade in the initial value, “7FH” by 8031 cycles. The OATTs are set to “00H” when PWDA goes “0”. After returning to “1”, the OATTs fade in the current value. The OATTs are set to “00H” when RSTDAN goes “0”. After returning to “1”, the OATTs fade in the current value.

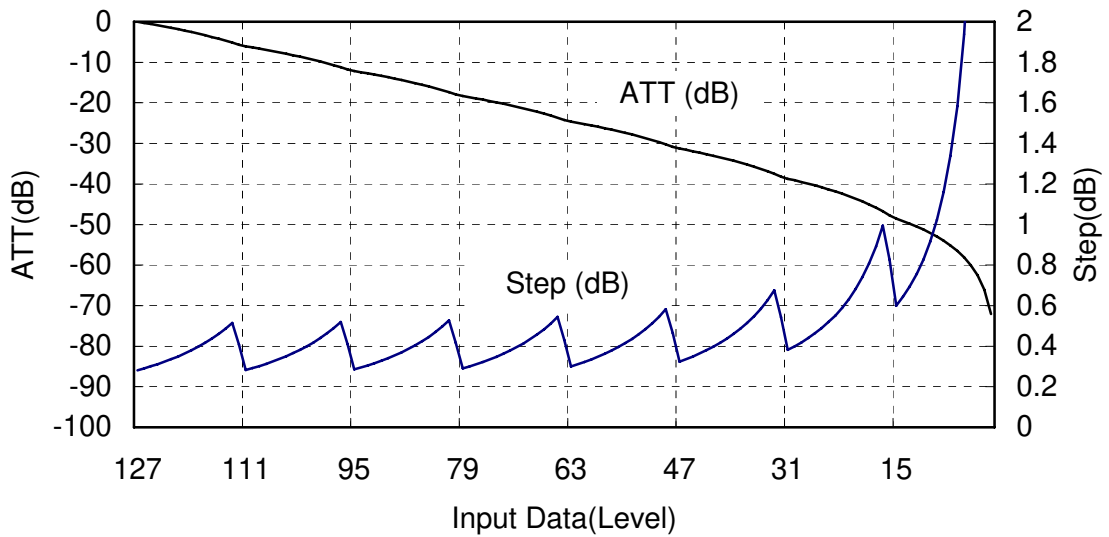

Figure 10. ATT characteristics

Data	Internal (DATT)	Gain (dB)	Step width (dB)	
127	8031	0	-	<p style="text-align: center;">OATT</p> <p>External 128 levels are converted to internal 8032 linear levels of DATT. Internal DATT soft-changes between DATAs.</p> <p>$DATT=2^m \times (2 \times l + 33) - 33$</p> <p>m: MSB 3-bits of data l: LSB 4-bits of data</p>
126	7775	-0.28	0.28	
125	7519	-0.57	0.29	
:	:	:	:	
112	4191	-5.65	0.51	
111	3999	-6.06	0.41	
110	3871	-6.34	0.28	
:	:	:	:	
96	2079	-11.74	0.52	
95	1983	-12.15	0.41	
94	1919	-12.43	0.28	
:	:	:	:	
80	1023	-17.90	0.53	
79	975	-18.32	0.42	
78	943	-18.61	0.29	
:	:	:	:	
64	495	-24.20	0.54	
63	471	-24.64	0.43	
62	455	-24.94	0.30	
:	:	:	:	
48	231	-30.82	0.58	
47	219	-31.29	0.46	
46	211	-31.61	0.32	
:	:	:	:	
32	99	-38.18	0.67	
31	93	-38.73	0.54	
30	89	-39.11	0.38	
:	:	:	:	
16	33	-47.73	0.99	
15	30	-48.55	0.83	
14	28	-49.15	0.60	
:	:	:	:	
5	10	-58.10	1.58	
4	8	-60.03	1.94	
3	6	-62.53	2.50	
2	4	-66.05	3.52	
1	2	-72.07	6.02	
0	0	MUTE		

Table 8. OATT code table

SYSTEM DESIGN

Figure 11 shows the system connection diagram. An evaluation board (AKD4528) is available which demonstrates application circuits, the optimum layout, power supply arrangements and measurement results.

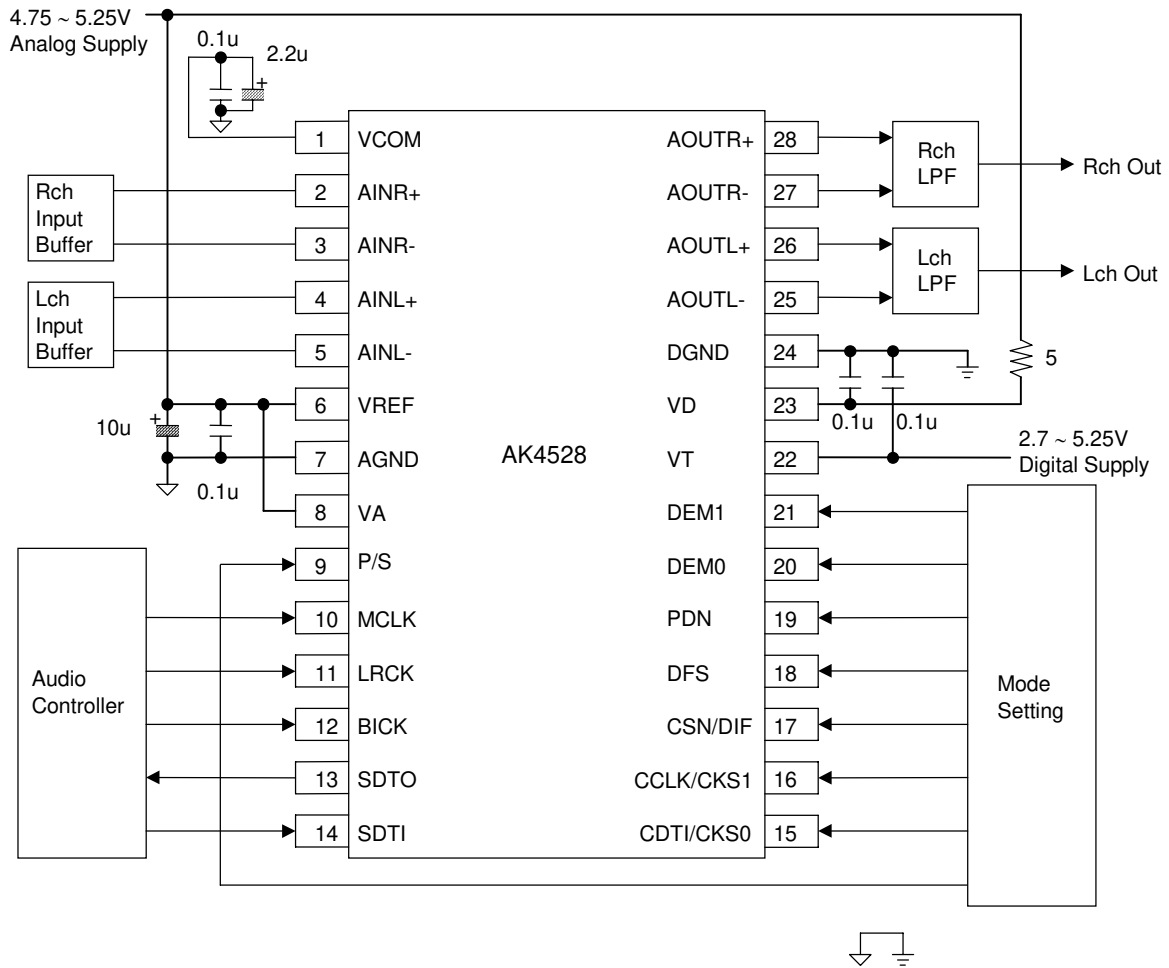

Notes:

- AGND and DGND of AK4528 should be distributed separately from the ground of external controller etc.
- When AOUT+/- drives some capacitive load, some resistor should be added in series between AOUT+/- and capacitive load.
- All input pins should not be left floating.

Figure 11. Typical Connection Diagram

1. Grounding and Power Supply Decoupling

The AK4528 requires careful attention to power supply and grounding arrangements. VA and VD are usually supplied from analog supply in system. Alternatively if VA and VD are supplied separately, the power up sequence is taken care. VT is a power supply pin to interface with the external ICs and is supplied from digital supply in system. AGND and DGND of the AK4528 should be connected to analog ground plane. System analog ground and digital ground should be connected together near to where the supplies are brought onto the printed circuit board. Decoupling capacitors should be as near to the AK4528 as possible, with the small value ceramic capacitor being the nearest.

2. Voltage Reference

The differential voltage between VREF and AGND sets the analog input/output range. VREF pin is normally connected to VA with a 0.1 μ F ceramic capacitor. VCOM is a signal ground of this chip. An electrolytic capacitor 2.2 μ F parallel with a 0.1 μ F ceramic capacitor attached to VCOM pin eliminates the effects of high frequency noise. No load current may be drawn from VCOM pin. All signals, especially clocks, should be kept away from the VREF and VCOM pins in order to avoid unwanted coupling into the AK4528.

3. Analog Inputs

The IPGA inputs are single-ended and the input resistance 27k Ω (typ. @fs=44.1kHz). The input signal range scales with the VREF voltage and nominally 0.56 x VREF Vpp. It is recommended that the input DC bias voltage is 0.56VA ~ 0.60VA as centered in the internal common voltage about VA/2). The AK4528 can accept input voltages from AGND to VA. The ADC output data format is 2's complement. The output code is 7FFFFFFH (@24bit) for input above a positive full scale and 800000H (@24bit) for input below a negative full scale. The ideal code is 000000H (@24bit) with no input signal. The DC offset including ADC own DC offset removed by the internal HPF (fc=0.9Hz@fs=44.1kHz). The AK4528 samples the analog inputs at 64fs. The digital filter rejects noise above the stopband except for multiples of 64fs. A simple RC filter may be used to attenuate any noise around 64fs though most audio signals do not have significant energy at 64fs. Figure 12 is an example of differential input circuit.

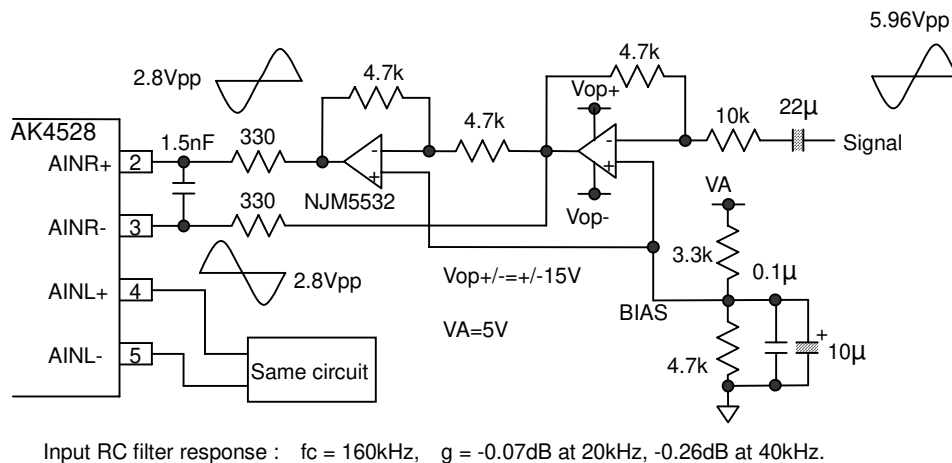

Figure 12. Differential Input Buffer Example

4. Analog Outputs

The analog outputs are full differential outputs and nominally $0.54 \times V_{REF} V_{pp}$ centered in the internal common voltage (about $V_A/2$). The differential outputs are summed externally, $V_{out} = (AOUT+) - (AOUT-)$ between AOUT+ and AOUT-. If the summing gain is 1, the output range is $5.4V_{pp}$ (typ@ $V_{REF}=5V$). The bias voltage of the external summing circuit is supplied externally. The input data format is 2's complement. The output voltage is a positive full scale for 7FFFFFFH(@24bit) and a negative full scale for 800000H(@24bit). The ideal AOUT is 0V for 000000H(@24bit).

The internal switched-capacitor filter and the external LPF attenuate the noise generated by the delta-sigma modulator beyond the audio passband.

Differential outputs can eliminate any DC offset on analog outputs without using capacitors. Figure 13 to Figure 15 show the example of external op-amp circuit summing the differential outputs.

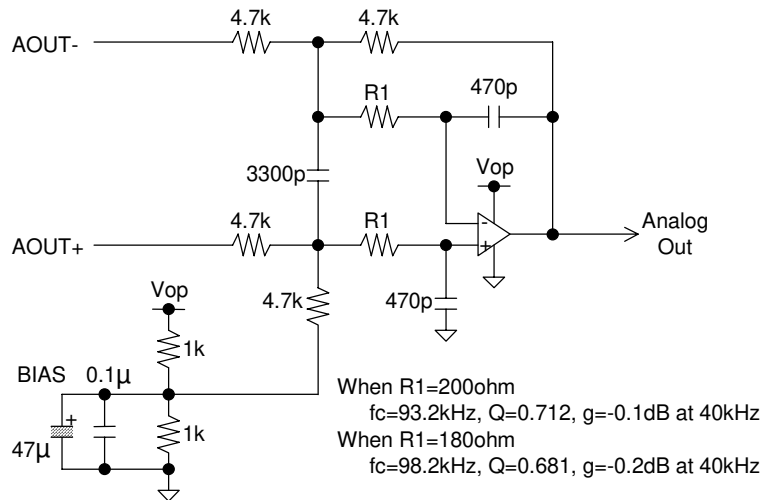

Figure 13. External 2nd order LPF Example (using single supply op-amp)

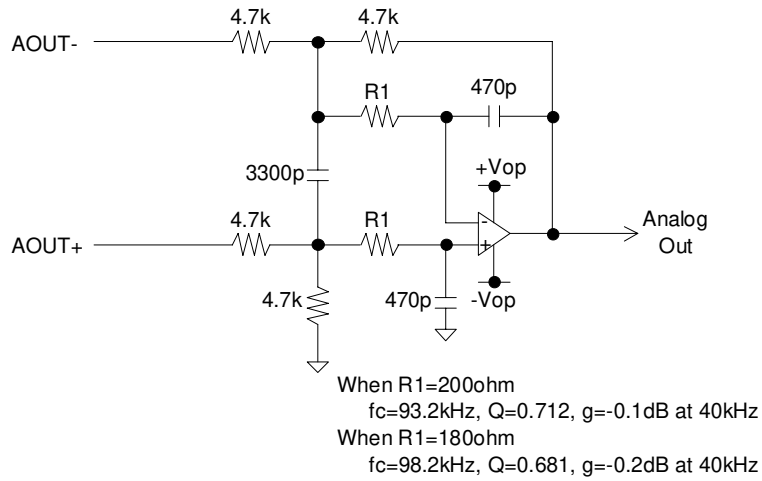

Figure 14. External 2nd order LPF Example (using dual supply op-amp)

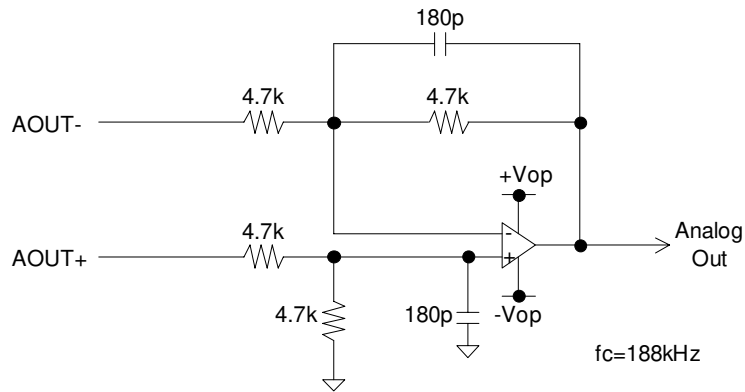

Figure 15. External low cost 1st order LPF Example (using dual supply op-amp)

■ Peripheral I/F Example

The digital inputs of the AK4528 are TTL inputs and can accept the signal of device with a nominal 3V supply. The digital output can interface with the peripheral device with a nominal 3V supply when the VT supply operates at a nominal 3V supply.

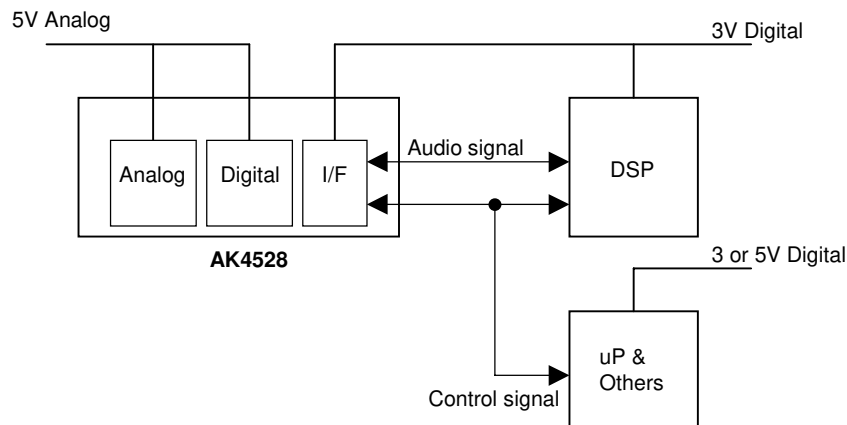
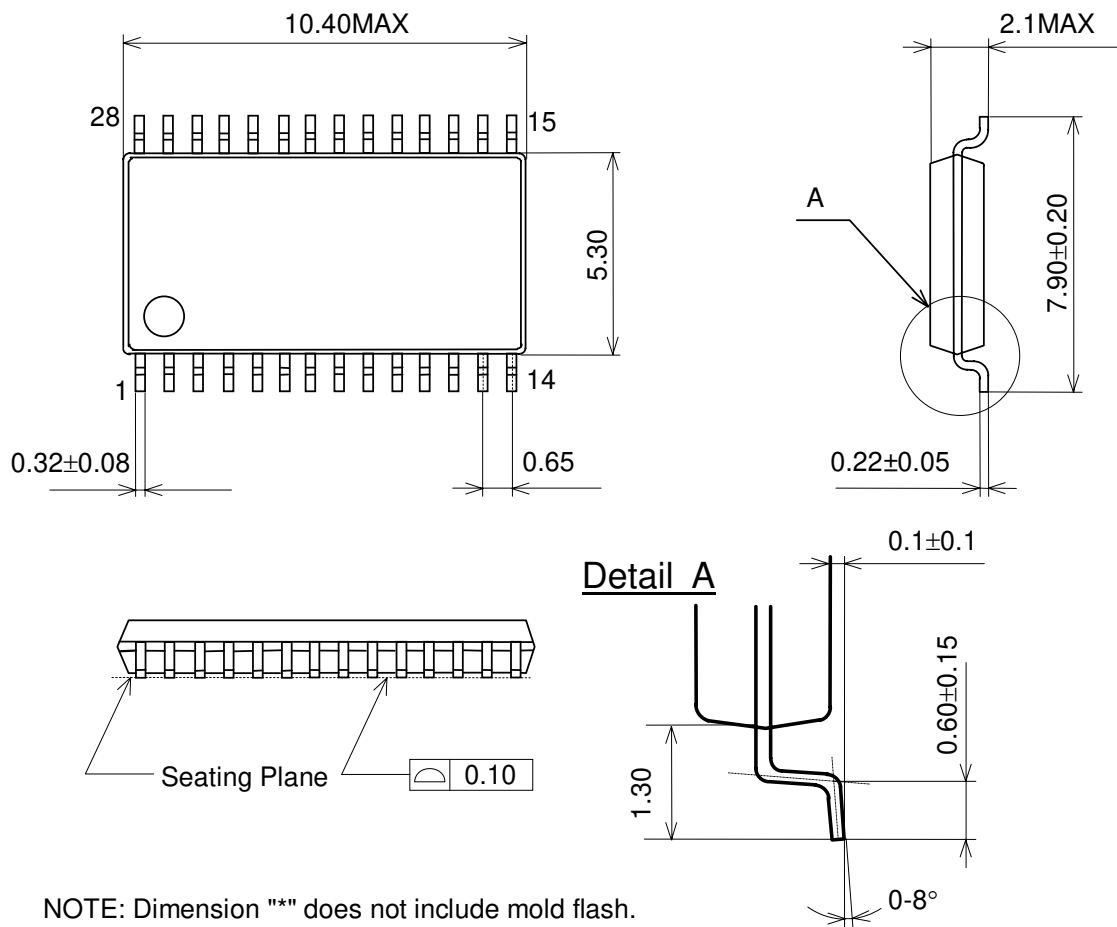

Figure 16. Power supply connection example

PACKAGE

28pin SSOP (Unit: mm)



NOTE: Dimension "*" does not include mold flash.

■ Package & Lead frame material

Package molding compound:	Epoxy
Lead frame material:	Cu
Lead frame surface treatment:	Solder plate

MARKING

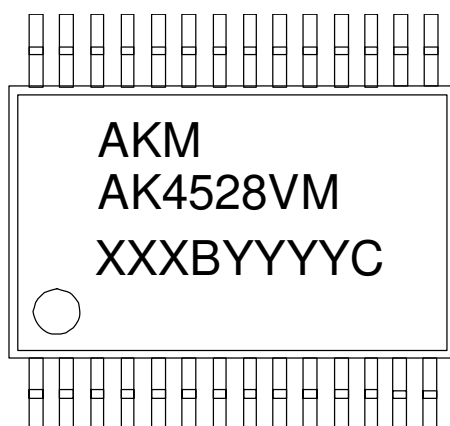

XXXBYYYYC: Date code identifier

XXXB: Lot number (X: Digit number, B: Alpha character)

YYYYC: Assembly date (Y: Digit number, C: Alpha character)

REVISION HISTORY

Date (Y/M/D)	Revision	Reason	Page	Contents
00/01/24	00	First Edition		
03/01/07	01	Error Correction	7	FILTER CHARACTERISTICS ADC Passband: 22.20 → 20.20
12/01/12	02	Specification Change	1, 3, 28, 29	AK4528VF was deleted. (28pin VSOP) AK4528VM was added. (28pin SSOP) Ordering Guide was changed. PACKAGE was changed. MARKING was changed.
13/03/08	03	Error Correction	29	MARKING Marking drawing was changed.

IMPORTANT NOTICE

0. Asahi Kasei Microdevices Corporation (“AKM”) reserves the right to make changes to the information contained in this document without notice. When you consider any use or application of AKM product stipulated in this document (“Product”), please make inquiries the sales office of AKM or authorized distributors as to current status of the Products.
1. All information included in this document are provided only to illustrate the operation and application examples of AKM Products. AKM neither makes warranties or representations with respect to the accuracy or completeness of the information contained in this document nor grants any license to any intellectual property rights or any other rights of AKM or any third party with respect to the information in this document. You are fully responsible for use of such information contained in this document in your product design or applications. **AKM ASSUMES NO LIABILITY FOR ANY LOSSES INCURRED BY YOU OR THIRD PARTIES ARISING FROM THE USE OF SUCH INFORMATION IN YOUR PRODUCT DESIGN OR APPLICATIONS.**
2. The Product is neither intended nor warranted for use in equipment or systems that require extraordinarily high levels of quality and/or reliability and/or a malfunction or failure of which may cause loss of human life, bodily injury, serious property damage or serious public impact, including but not limited to, equipment used in nuclear facilities, equipment used in the aerospace industry, medical equipment, equipment used for automobiles, trains, ships and other transportation, traffic signaling equipment, equipment used to control combustions or explosions, safety devices, elevators and escalators, devices related to electric power, and equipment used in finance-related fields. Do not use Product for the above use unless specifically agreed by AKM in writing.
3. Though AKM works continually to improve the Product’s quality and reliability, you are responsible for complying with safety standards and for providing adequate designs and safeguards for your hardware, software and systems which minimize risk and avoid situations in which a malfunction or failure of the Product could cause loss of human life, bodily injury or damage to property, including data loss or corruption.
4. Do not use or otherwise make available the Product or related technology or any information contained in this document for any military purposes, including without limitation, for the design, development, use, stockpiling or manufacturing of nuclear, chemical, or biological weapons or missile technology products (mass destruction weapons). When exporting the Products or related technology or any information contained in this document, you should comply with the applicable export control laws and regulations and follow the procedures required by such laws and regulations. The Products and related technology may not be used for or incorporated into any products or systems whose manufacture, use, or sale is prohibited under any applicable domestic or foreign laws or regulations.
5. Please contact AKM sales representative for details as to environmental matters such as the RoHS compatibility of the Product. Please use the Product in compliance with all applicable laws and regulations that regulate the inclusion or use of controlled substances, including without limitation, the EU RoHS Directive. AKM assumes no liability for damages or losses occurring as a result of noncompliance with applicable laws and regulations.
6. Resale of the Product with provisions different from the statement and/or technical features set forth in this document shall immediately void any warranty granted by AKM for the Product and shall not create or extend in any manner whatsoever, any liability of AKM.
7. This document may not be reproduced or duplicated, in any form, in whole or in part, without prior written consent of AKM.