

Product brief

MOTIX™ Bridge TLE94xyz DC motor driver family

The MOTIX™ TLE94xyz are protected half-bridge drivers designed for automotive motion control applications such as small DC motors for Heating, Ventilation and Air Conditioning (HVAC), as well as mirror adjustment and fold. The family offers 3-, 4-, 6-, 8-, 10-, and 12-fold integrated half-bridge driver. All devices can drive DC motor loads up to 0.9 A per output in cascaded or parallel operation. They provide diagnosis of short circuit, open load, power supply failure and overtemperature for each half-bridge to ensure safe operation in HVAC or other systems. The MOTIX™ TLE94xyz offers enhanced EMC performance, which in combination with the low quiescent current and a small package makes the products attractive for automotive and other applications.

Key benefits

- > Variable driving schemes for up to 11 motors
- > Diagnosis of each output via SPI
- > Device operates down to 5.5 V (supporting start stop systems of fuel efficient vehicles)
- > OUT 1 and 2 optimized for driving HS loads (e.g. LED)

Block diagram MOTIX™ TLE94112ES

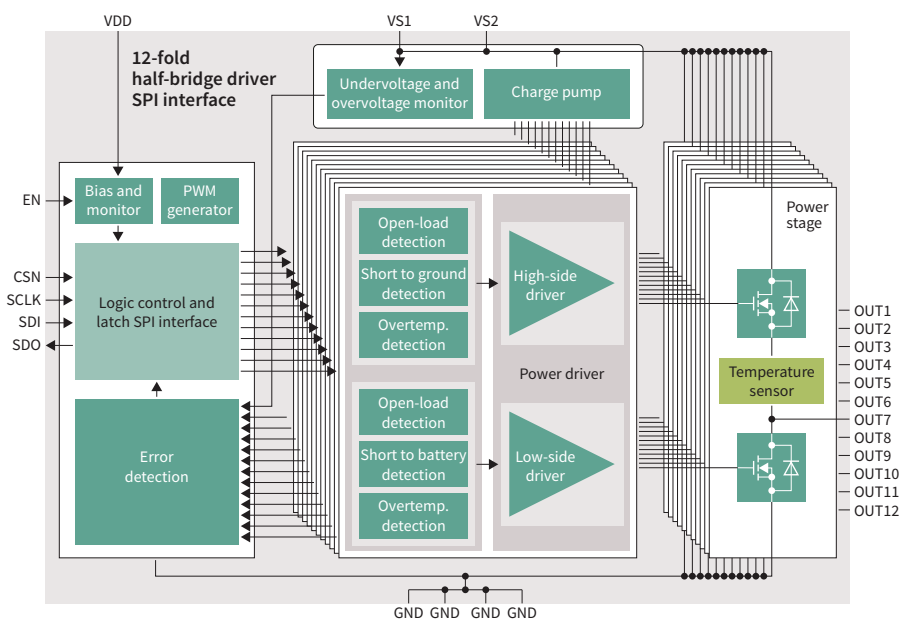

Key features

- > 3, 4, 6, 8, 10, 12-half-bridges with integrated output stages & PWM
- > 16-bit SPI or DI for control & diagnosis
- > Voltage supply range: 5.5–20 V
- > Adjustable open load threshold for two outputs

Key applications

- > Flap motors in HVAC systems
- > Mirror adjustment and fold
- > Small DC motors (≤ 0.9 A/output)
- > Bi-stable relays



MOTIX™ TLE94xyz DC motor driver

Integrated multi half-bridge driver ICs

Application diagram

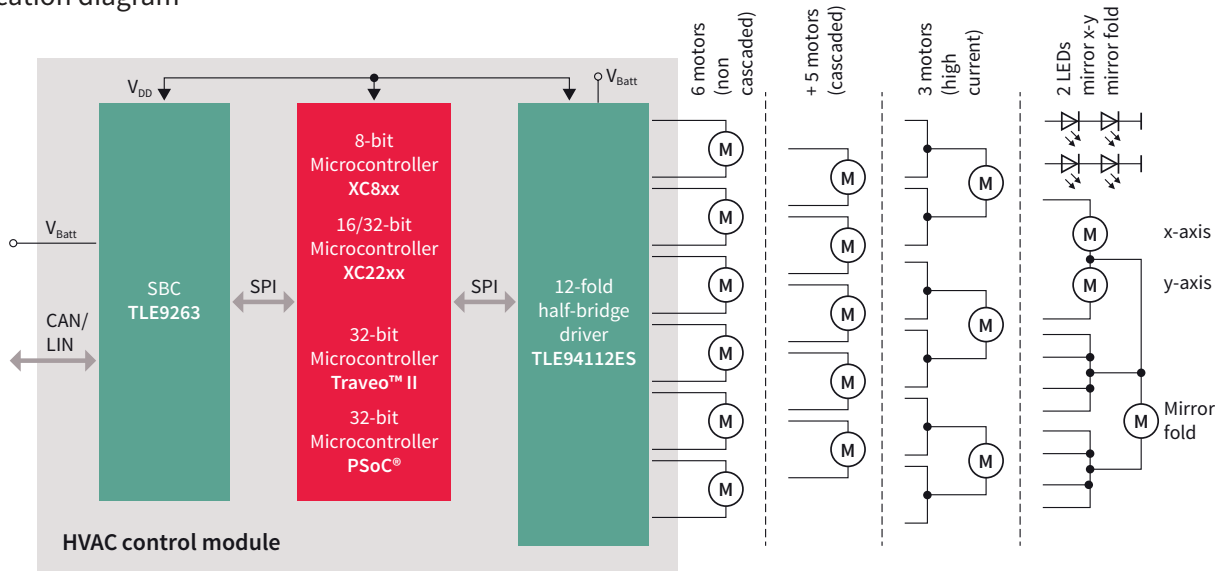

Example: The MOTIX™ TLE94112ES, 12-fold half-bridge, is designed to either drive 6 DC motors up to 0.9 A in parallel mode or 11 DC motors up to 0.9 A in cascaded mode or up to 3 DC motors up to 1.8 A by paralleling two outputs each. The device is sold in a PG-TSDSO-24 package and is pin and function compatible with the 6-, 8-, and 10-fold half-bridge of the TLE94xyz family.

The driver is connected via a 16-bit SPI to the microcontroller. The enhanced SPI protocol allows independent control and diagnosis of each half-bridge. All outputs can be programmed for PWM and the user can select between active and passive freewheeling for each output. The device can be operated in daisy chain mode.

Product table

Type	Description	OUT1/2 configurable	Package
MOTIX™ TLE94112ES	12-fold integrated half-bridge driver IC with SPI	Yes	PG-TSDSO-24
MOTIX™ TLE94110ES	10-fold integrated half-bridge driver IC with SPI	Yes	PG-TSDSO-24
MOTIX™ TLE94108ES	8-fold integrated half-bridge driver IC with SPI	Yes	PG-TSDSO-24
MOTIX™ TLE94106ES	6-fold integrated half-bridge driver IC with SPI	Yes	PG-TSDSO-24
MOTIX™ TLE94004EP	4-fold integrated half-bridge driver IC with DI	No	PG-TSDSO-14
MOTIX™ TLE94104EP	4-fold integrated half-bridge driver IC with SPI	No	PG-TSDSO-14
MOTIX™ TLE94003EP	3-fold integrated half-bridge driver IC with DI	No	PG-TSDSO-14
MOTIX™ TLE94103EP	3-fold integrated half-bridge driver IC with SPI	No	PG-TSDSO-14

Published by
Infineon Technologies AG
81726 Munich, Germany

© 2021 Infineon Technologies AG.
All Rights Reserved.

Please note!

This Document is for information purposes only and any information given herein shall in no event be regarded as a warranty, guarantee or description of any functionality, conditions and/or quality of our products or any suitability for a particular purpose. With regard to the technical specifications of our products, we kindly ask you to refer to the relevant product data sheets provided by us. Our customers and their technical departments are required to evaluate the suitability of our products for the intended application.

We reserve the right to change this document and/or the information given herein at any time.

Additional information

For further information on technologies, our products, the application of our products, delivery terms and conditions and/or prices, please contact your nearest Infineon Technologies office (www.infineon.com).

Warnings

Due to technical requirements, our products may contain dangerous substances. For information on the types in question, please contact your nearest Infineon Technologies office.

Except as otherwise explicitly approved by us in a written document signed by authorized representatives of Infineon Technologies, our products may not be used in any life-endangering applications, including but not limited to medical, nuclear, military, life-critical or any other applications where a failure of the product or any consequences of the use thereof can result in personal injury.