

REVISIONS			
REV	DESCRIPTION	DATE	APPROVED
01 ₄	REVISED	10/24/97	TWag

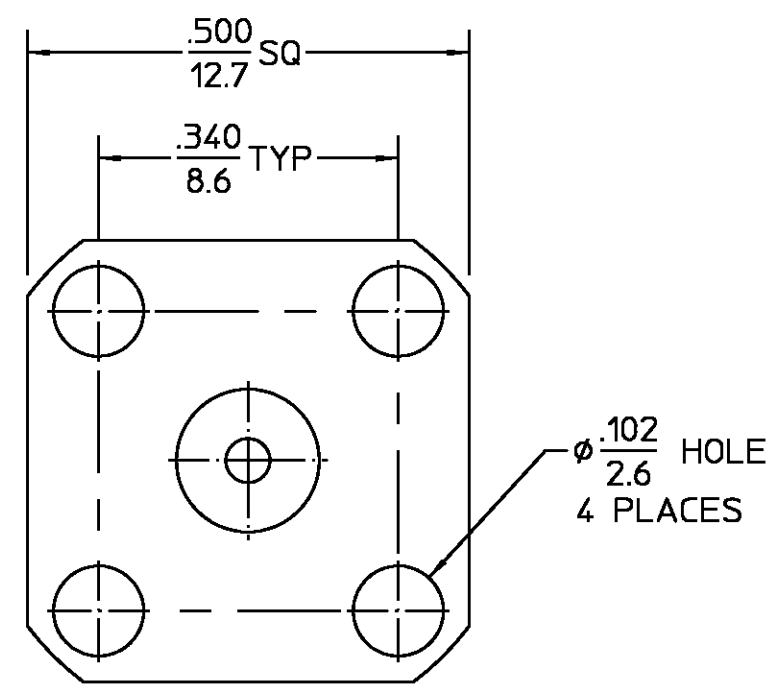
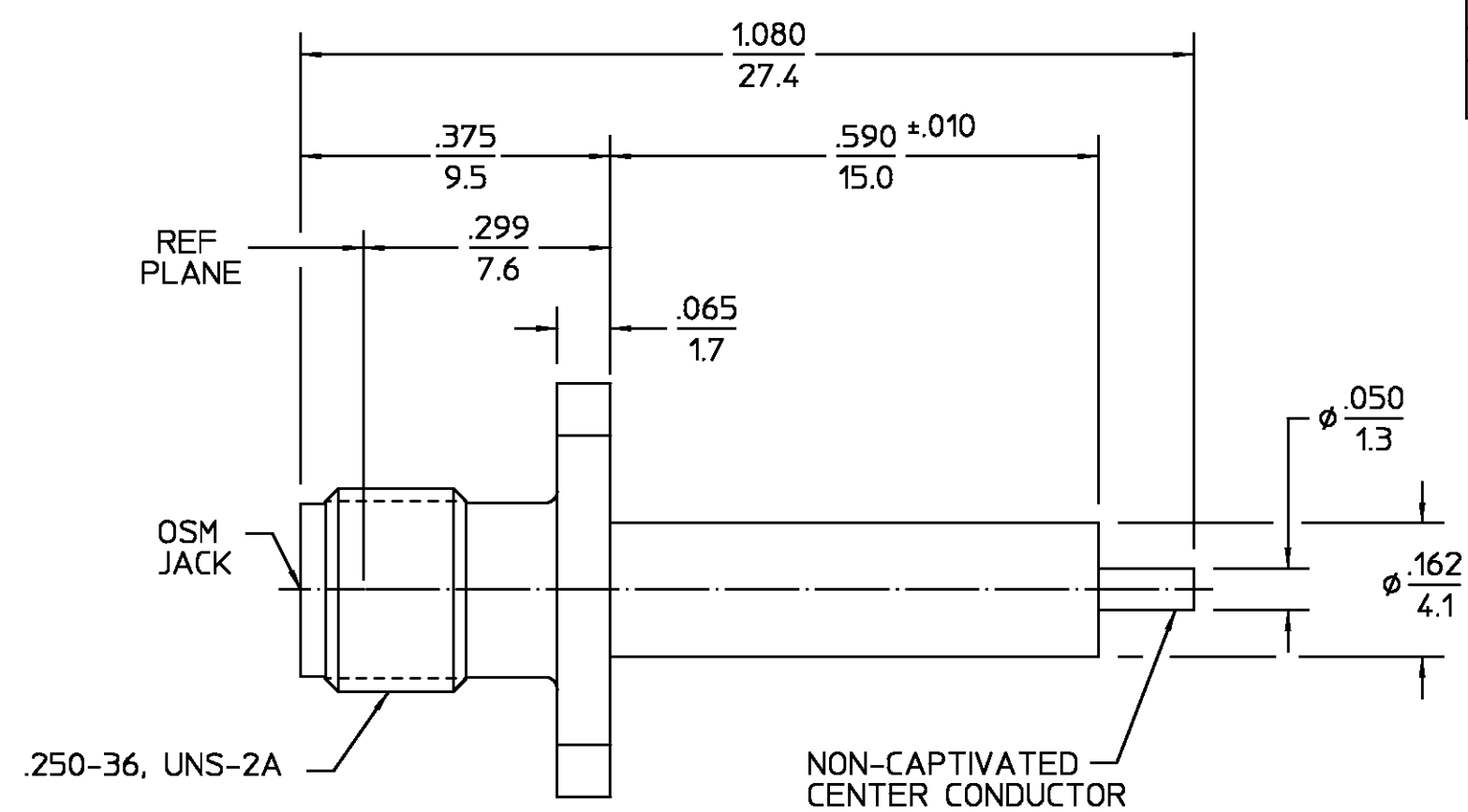

ELECTRICAL	MECHANICAL	ENVIRONMENTAL
Nominal Impedance (Ohms) <u>50</u>	Interface Dimensions MIL-STD-348, Fig. <u>310-2</u>	Temperature Rating <u>-65°C To 165°C</u>
Frequency Range (GHz) DC to <u>18</u>	Recommended Mating Torque <u>7-10 In-Lbs</u>	Vibration MIL-STD-202, Method 204, Condition D.
Volt Rating (VRMS MAX) @ Sea Level <u>335</u>	Mating Characteristics: Insertion (MAX Lbs) <u>2.0</u>	Shock MIL-STD-202, Method 213, Condition I.
VSWR <u>1.03 + .004f (GHz)</u>	Withdrawal (MIN Oz) <u>1.0</u>	Thermal Shock MIL-STD-202, Method 107, Condition B
Insertion Loss (dB MAX) <u>.03√f(GHz)</u>	Force to Engage and Disengage (In/Lbs MAX) <u>2.0</u>	Moisture Resistance MIL-STD-202, Method 106, Except Vibration
RF Leakage (dB MIN) <u>-[100-f(GHz)]</u>	Center Contact Captivation: Axial (Lbs) <u>N/A</u>	Shall Be Omitted
Corona, 70,000 Ft (VRMS MIN) <u>250</u>	Radial (In/Oz) <u>N/A</u>	Corrosion - MIL-STD-202, Method 101, Condition B, 5% salt spray
Dielectric Withstanding Voltage (VRMS MIN) @ Sea Level <u>1,000</u>	Weight (Grams) <u>TBD</u>	
Contact Resistance (Milliohms MAX): Center Contact <u>2.0</u>		
Outer Contact <u>2.0</u>		
Cable to Housing <u>N/A</u>		
RF High Potential @ Sea Level (VRMS MIN @ 5 MHz) <u>670</u>		
I.R.(Megohms MIN) <u>10,000</u>		

COMPONENT	MATERIAL	FINISH
HOUSING	STAINLESS STEEL PER ASTM-A484 AND ASTM-A582, TYPE 303	GOLD PLATE PER MIL-G-45204
DIELECTRIC	TFE FLUOROCARBON PER ASTM-D-1457	N/A
CENTER CONTACT	BERYLLIUM COPPER PER ASTM-B 196, ALLOY C17300, CONDITION H	GOLD PLATE PER MIL-G-45204

UNLESS OTHERWISE SPECIFIED DIMENSIONS ARE IN INCHES TOLERANCE ON FRAC. DEC. ANGLES ± 1/64 ±.005 ± °	DRAWN BY <u>BWC</u> DATE <u>6/6/67</u>	AMP AMP Incorporated 140 Fourth Avenue Waltham, MA 02451-7599
	CHECKED BY <u>PRB</u> DATE <u>7/5/68</u>	
	APPD BY <u>7/3/68</u>	

USE ASS'Y PROCEDURE	TITLE <u>OSM 4 HOLE FLANGE MOUNT JACK RECEPTACLE STRAIGHT TERMINAL</u>
NO. AP. <u>N/A</u>	SIZE <u>B</u> CODE IDENT NO. <u>26805</u> 2052-1200-00 REV <u>01₄</u>
	SCALE <u>5:1</u> SHEET 1 OF 1

.XXX = in
XX.X = mm

CUSTOMER DRAWING

AMP PART # 1052517-1
SHEET 1 OF 1 REV A