

RFid Reader™

Manual

All Mikroelektronika's development systems feature a large number of peripheral modules expanding microcontroller's range of application and making the process of program testing easier. In addition to these modules, it is also possible to use numerous additional modules linked to the development system through the I/O port connectors. Some of these additional modules can operate as stand-alone devices without being connected to the microcontroller.

Additional Board

 **MikroElektronika**

SOFTWARE AND HARDWARE SOLUTIONS FOR EMBEDDED WORLD ...making it simple

RFid Reader

The *RFid Reader* additional board is used to read identification cards (*RFid Cards*) using radio waves. This additional board features a receiver/transmitter module with antenna and a 2x5 male connector that enables connection with development systems. The operation of the *RFid Reader* board is based on amplitude modulation of radio waves and electromagnetic induction. The *RFid* card is not provided with the *RFid Reader*, but you can buy it separately.

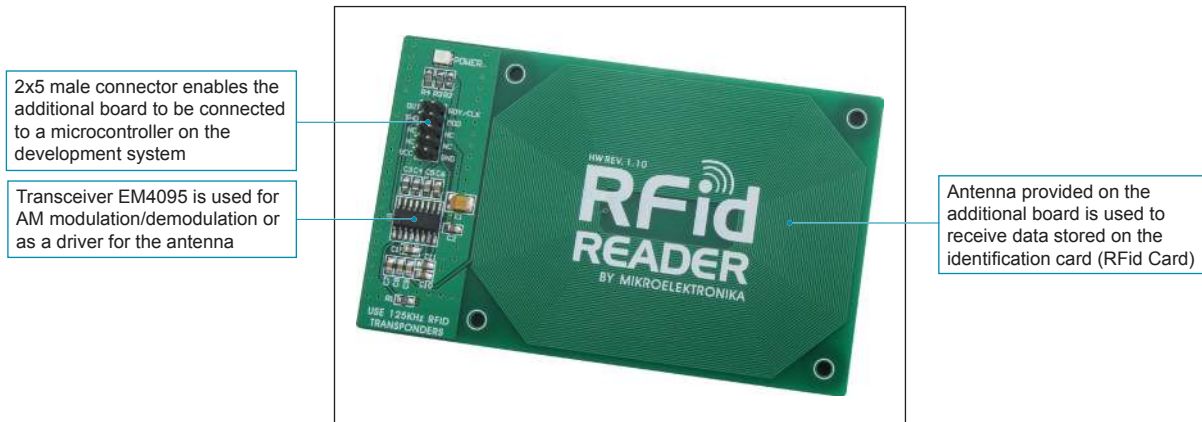

Figure 1: *RFid Reader*

RFid Reader is powered via a development system it is connected to. The presence of the power supply is indicated by a LED marked POWER. When the *RFid Reader* is turned on, a 125kHz voltage is supplied on its antenna. As a result, the antenna starts emitting an electromagnetic field necessary for reading the *RFid* identification card. As passive *RFid* card doesn't have its own power supply, it features a coil where the voltage is automatically induced by approaching the card to the *RFid Reader's* antenna. This voltage is necessary for the chip featured on the *RFid* card to work. The memory chip on the *RFid* card contains a unique identification code. This code is sent by the card when it is placed close to the *RFid Reader's* antenna. The code is received via this antenna. Then, it is sent to the microcontroller for further processing.



Figure 2: Identification card (*RFid Card*)

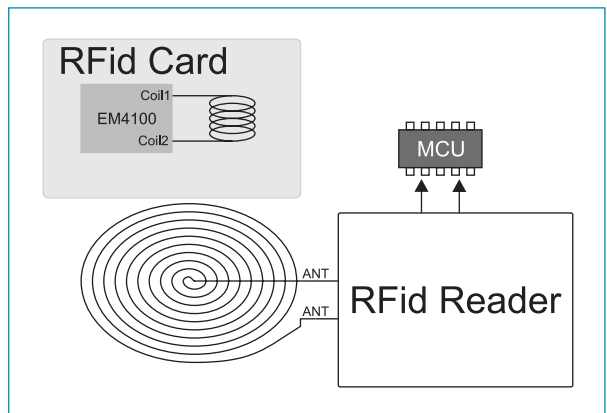

Figure 3: The principle of *RFid Reader's* operation

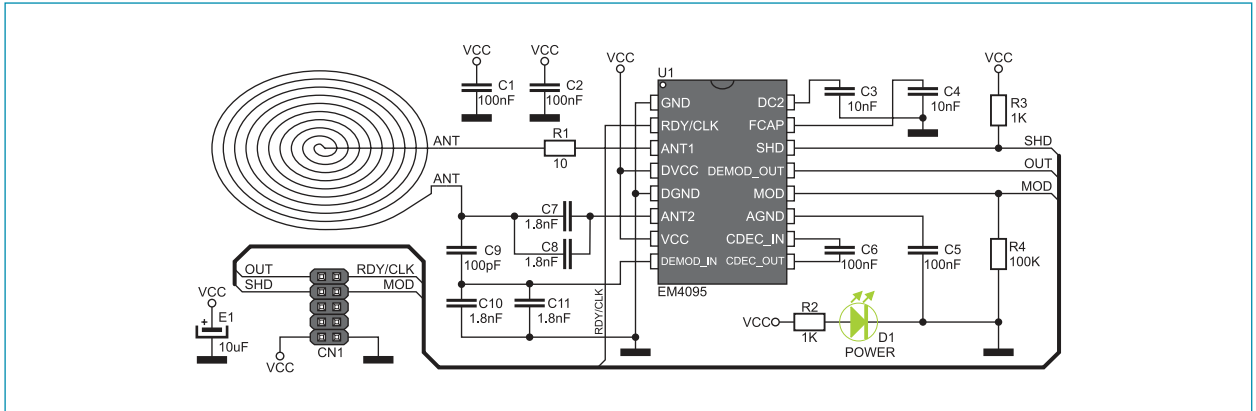

Figure 4: RFid Reader connection schematic

The function of pins provided on the 2x5 male connector CN1:

- OUT - Output signal from the EM4095 circuit (the code read from the identification card)
- RDY/CLK - Clock frequency pin and flag
- SHD - High voltage on this pin causes the *RFid Reader* to enter *sleep mode*
- MOD - High voltage on this pin causes signal modulation on the antenna to start

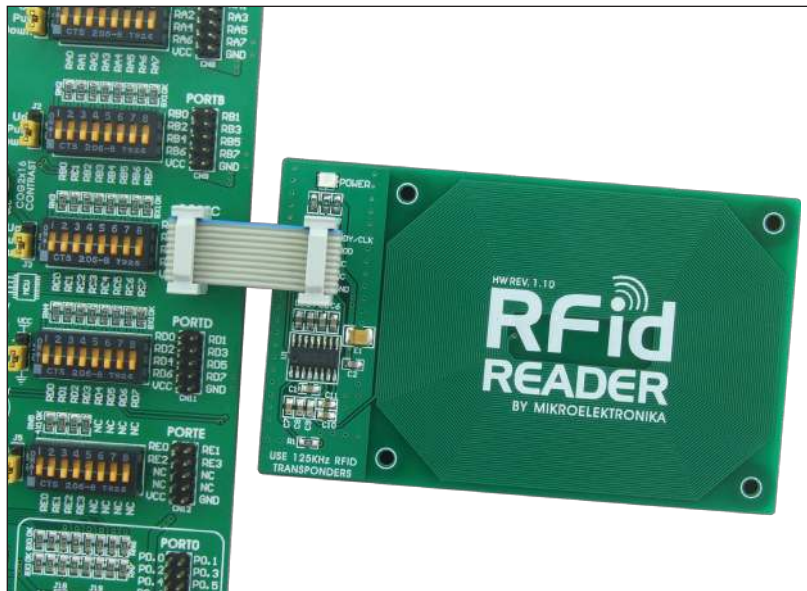

Figure 5: RFid Reader connected to a development system