

Features

- 2835 0.7mm SMD LED
- High Brightness
- White package
- High reliability
- Water Clear Lens

Applications

- Consumer Electronics
- Wearables
- Automobile After Market
- Industrial Equipment

Description

The IN-P23CTUW.70.45 is a 2835 package with versatile design capabilities. It is a PLCC type LED which can be used in various applications.

Recommended Solder Pattern

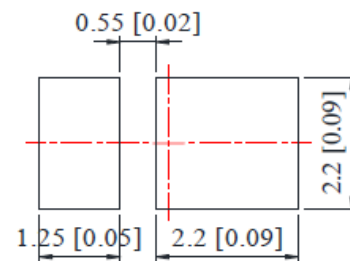
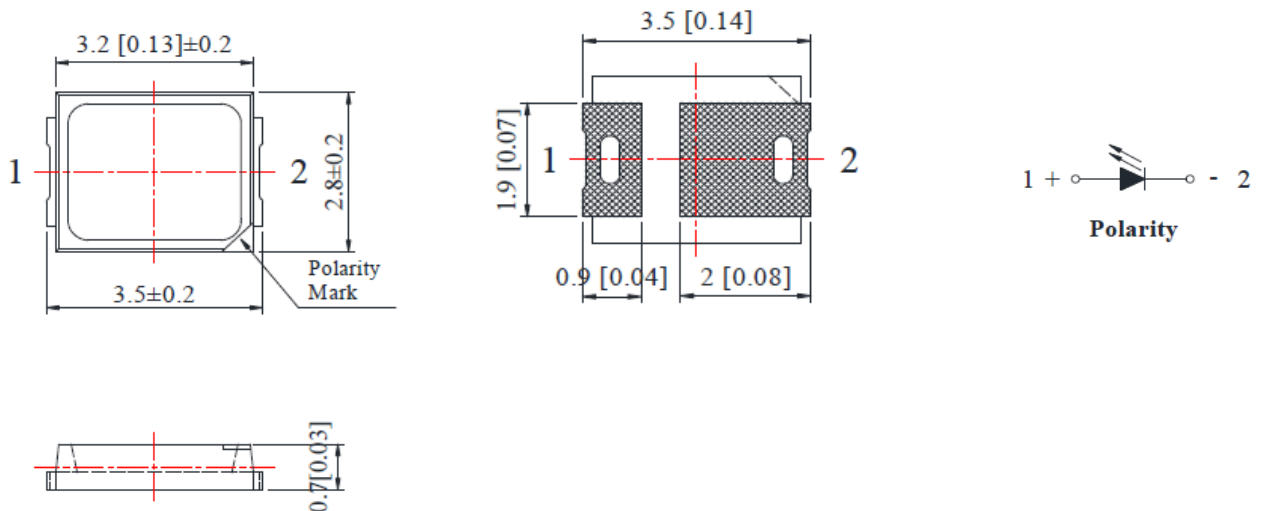

Figure 1. IN-P23CTKUW.70.45 Solder Pattern

Package Dimensions in mm



Notes:

1. All dimensions are in millimeters (inches).
2. Tolerance is ± 0.25 mm (.010") unless otherwise noted.

Figure 2. IN-P23CTKUW.70.45 Package Dimensions

Absolute Maximum Rating at 25°C (Note 1)

Product	Emission Color	P _d (mW)	I _F (mA)	I _{FP} * (mA)	V _R (V)	T _{OP} (°C)	T _{ST} (°C)
IN-P23CTKUW.70.45	White	0.5	150	200	5	-40°C~+80°C	-40°C~+85°C

Notes

1. Derate linearly as shown in derating curve.
2. Duty Factor = 10%, Frequency = 1 kHz

Electrical Characteristics *T_A = 25°C* (Note 1)

Parameters	Symbol	Min.	Typ.	Max.	Unit	Test Condition
Luminous Flux	IV	50	---	65	lm	IF=150mA
Viewing Angle	2θ1/2	---	120	---	Deg	IF=150mA
Chromaticity Coordinates	Cx/Cy	---	0.37/0.37	---	-	IF=150mA
Color Temperature	CCT	3800	4500	5000	K	IF=150mA
Color Rendering Index	CRI	70	---	---	Ra	IF=150mA
Forward Voltage	VF	2.8	3.2	3.6	V	IF=150mA
Reverse Current	I _R	---	---	10	μA	V _R =5V

Notes

1. Luminous intensity is measured with a light sensor and filter combination that approximates the CIE eye-response curve.
2. 2θ1/2 is the θ -axis angle where the luminous intensity is 1/2 the peak intensity
3. The dominant wavelength (λ_d) is derived from the CIE chromaticity diagram and represents the single wavelength which defines the color of the device.

Chromaticity Bin : Typ. CCT 4500K

Chromaticity Coordinates Specifications for Bin Rank:

Bin Code	Left x	Left y	Top x	Top y	Right x	Right y	Bottom x	Bottom y
G1-1	0.346	0.362	0.352	0.366	0.353	0.378	0.347	0.373
G2-1	0.345	0.351	0.351	0.356	0.352	0.366	0.346	0.362
G3-1	0.344	0.340	0.350	0.344	0.351	0.356	0.345	0.351
G4-1	0.343	0.328	0.348	0.332	0.350	0.344	0.344	0.340
G1-2	0.352	0.366	0.359	0.371	0.360	0.383	0.353	0.378
G2-2	0.351	0.356	0.357	0.359	0.359	0.371	0.352	0.366
G3-2	0.350	0.344	0.355	0.348	0.357	0.359	0.351	0.356
G4-2	0.348	0.332	0.353	0.336	0.355	0.348	0.350	0.344
G1-3	0.359	0.371	0.366	0.377	0.368	0.389	0.360	0.383
G2-3	0.357	0.359	0.364	0.365	0.366	0.377	0.359	0.371
G3-3	0.355	0.348	0.361	0.352	0.364	0.365	0.357	0.359
G4-3	0.353	0.336	0.359	0.340	0.361	0.352	0.355	0.348
G1-4	0.366	0.377	0.374	0.383	0.377	0.396	0.368	0.389
G2-4	0.364	0.365	0.371	0.370	0.374	0.383	0.366	0.377
G3-4	0.361	0.352	0.368	0.357	0.371	0.370	0.364	0.365
G4-4	0.359	0.340	0.365	0.345	0.368	0.357	0.361	0.352
G1-5	0.374	0.383	0.384	0.390	0.387	0.403	0.377	0.396
G2-5	0.371	0.370	0.380	0.377	0.384	0.390	0.374	0.383
G3-5	0.368	0.357	0.376	0.363	0.380	0.377	0.371	0.370
G4-5	0.365	0.345	0.373	0.351	0.376	0.363	0.368	0.357
H1-1	0.383	0.390	0.392	0.394	0.396	0.408	0.387	0.403
H2-1	0.380	0.377	0.388	0.381	0.392	0.394	0.383	0.390
H3-1	0.376	0.363	0.384	0.367	0.388	0.381	0.380	0.377
H4-1	0.373	0.351	0.380	0.354	0.384	0.367	0.376	0.363

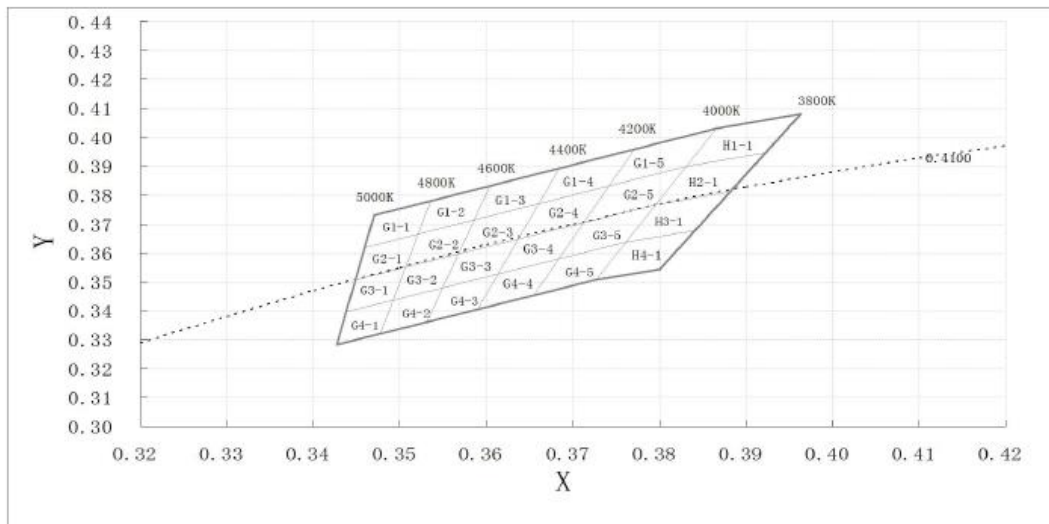

ESD Precaution

ATTENTION: Electrostatic Discharge (ESD) protection



The symbol above denotes that ESD precaution is needed. ESD protection for GaP and AlGaAs based chips is necessary even though they are relatively safe in the presence of low static-electric discharge. Parts built with AlInGaP, GaN, or/and InGaN based chips are STATIC SENSITIVE devices. ESD precaution must be taken during design and assembly. If manual work or processing is needed, please ensure the device is adequately protected from ESD during the process.

Please be advised that normal static precautions should be taken in the handling and assembly of this device to prevent damage or degradation which may be induced by electrostatic discharge (ESD).

Typical Characteristic Curves

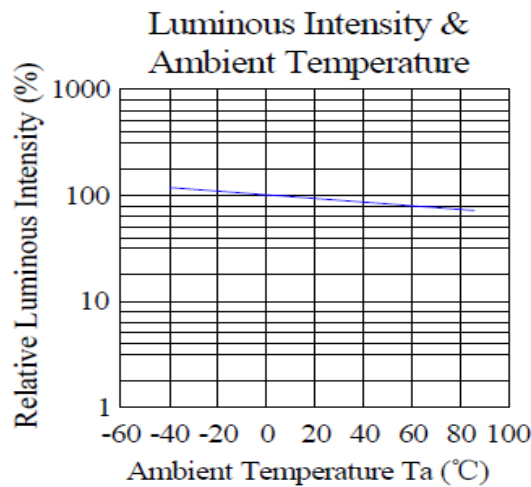
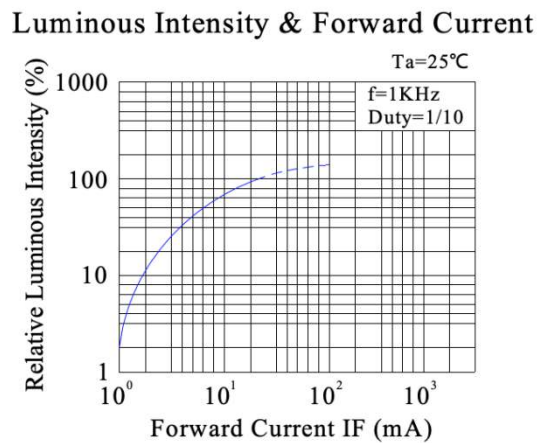
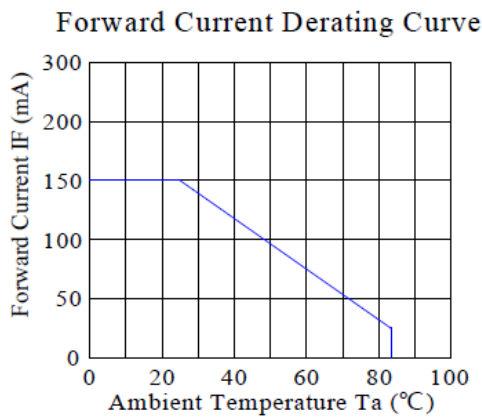
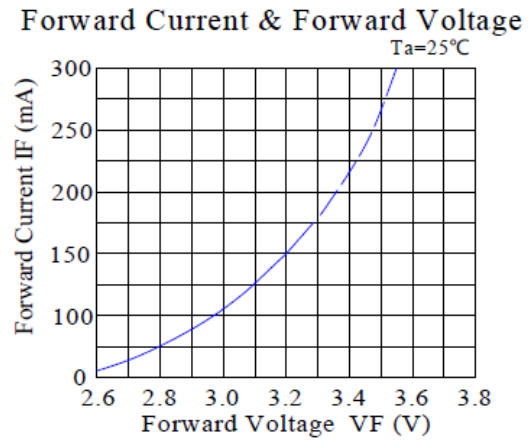
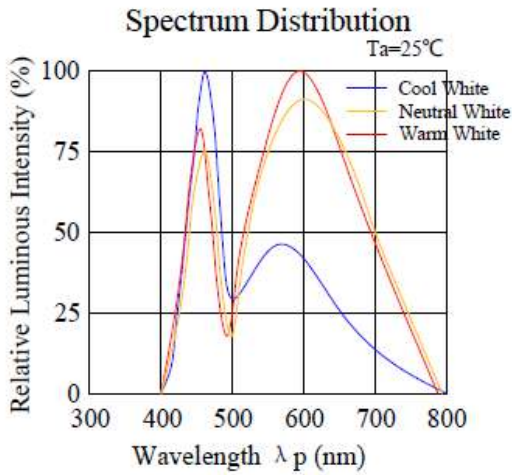

Typical Characteristic Curves – Radiation Pattern

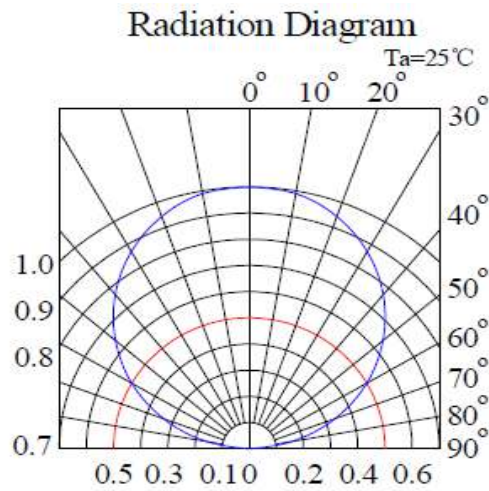

Ordering Information

Product	Emission Color	Test Current I_F (mA)	Luminous Flux I_V (lm) (Typ.)	Forward Voltage V_F (V) (Typ.)	Orderable Part Number
IN-P23CTKUW.70.45	White	150	52	3.2	IN-P23CTKUW.70.45

Label Specifications

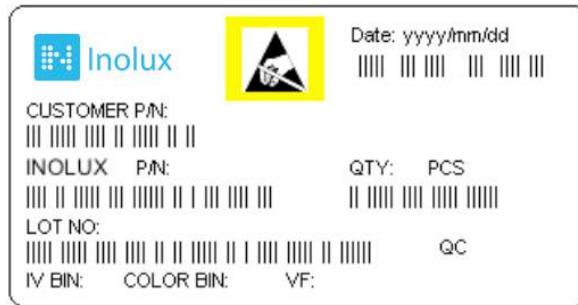

Inolux P/N:

I	N	-	P	2	3	C	T	K	U	W	.	70	.	45	-	X	X	X	X
			Material	Package	Variation	Orientation	Current	Lens	Color	.	CRI	.	CCT	-	Customized Stamp-off				
Inolux	SMD		P = PLCC Type	23C=PLCC2 2835 Slug		T = Top Mount	K=150mA	U = Diffused	W= White	.	70=CRI70	.	45=4500K						

Lot No.:

Z	2	0	1	8	01	24	001
Internal Tracker	Year (2018, 2019,)				Month	Date	Serial

Packaging Information: 4000pcs Per Reel

Tape Dimension

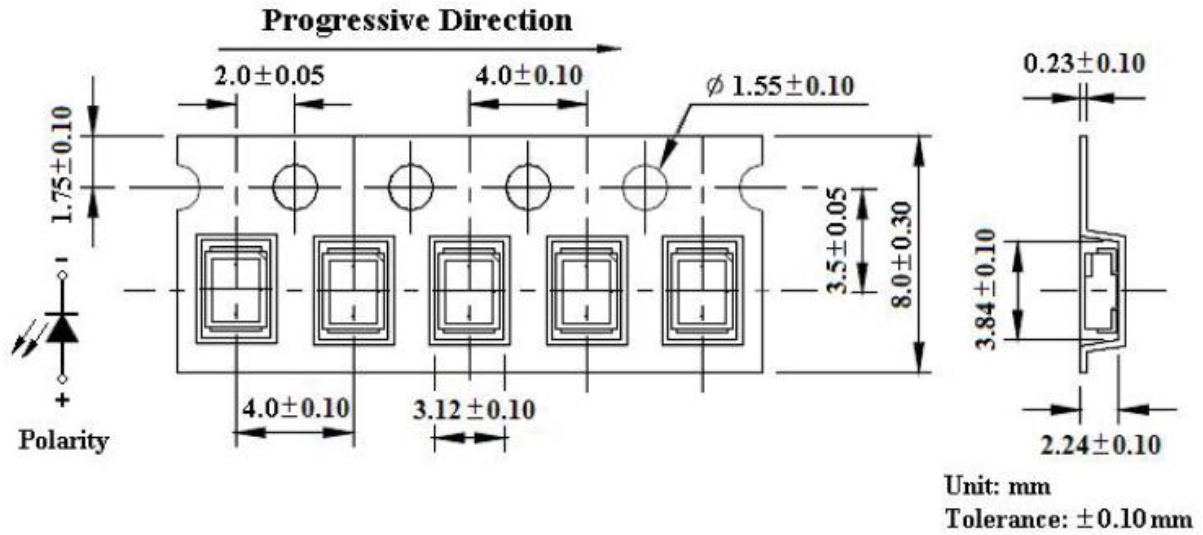

Reel Dimension

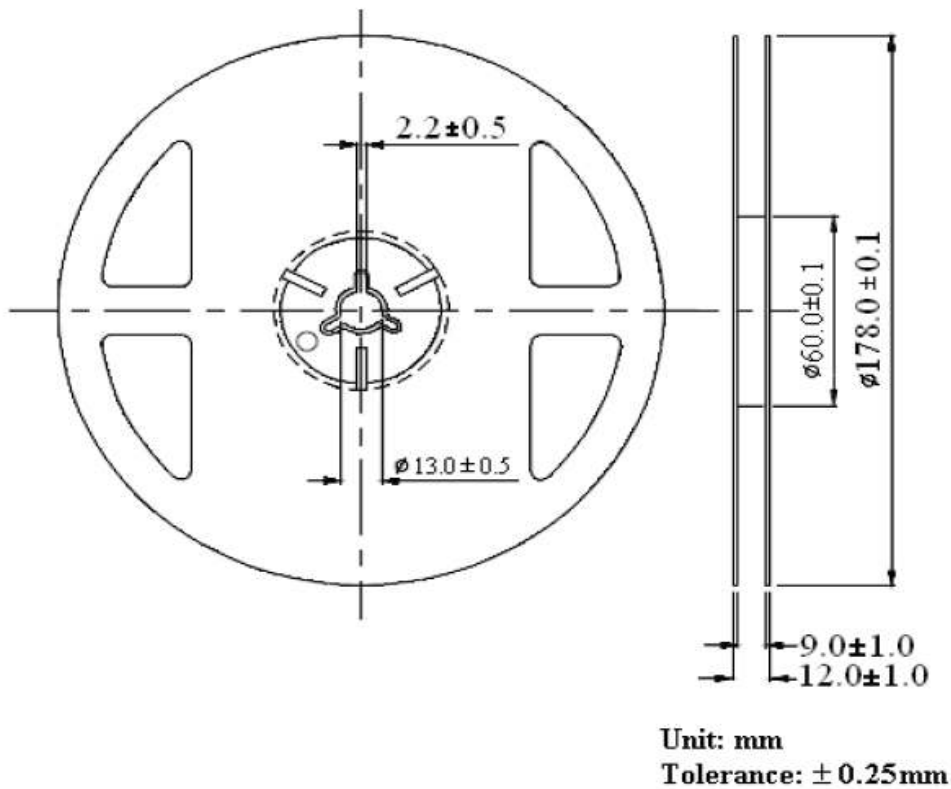

Packing Dimension

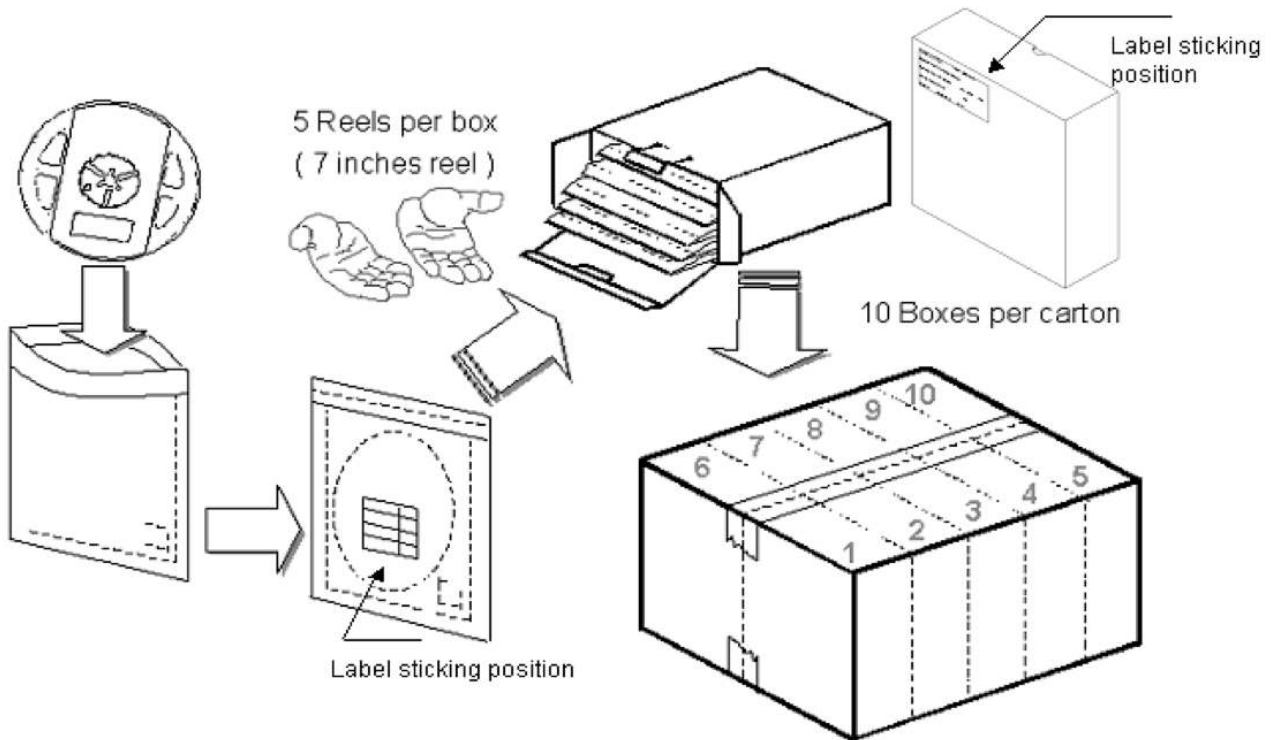

5 boxes per carton are available depending on shipment quantity.

	Specification	Material	Quantity
Carrier tape	Per EIA 481-1A specs	Conductive black tape	4000pcs per reel
Reel	Per EIA 481-1A specs	Conductive black	
Label	IN standard	Paper	
Packing bag	220x240mm	Aluminum laminated bag/ no-zipper	One reel per bag
Carton	IN standard	Paper	Non-specified

Others:

Each immediate box consists of 5 reels. The 5 reels may not necessarily have the same lot number or the same bin combinations of I_v , λ_D and V_f . Each reel has a label identifying its specification; the immediate box consists of a product label as well.

Dry Pack

All SMD optical devices are **MOISTURE SENSITIVE**. Avoid exposure to moisture at all times during transportation or storage. Every reel is packaged in a moisture protected anti-static bag. Each bag is properly sealed prior to shipment.

Upon request, a humidity indicator will be included in the moisture protected anti-static bag prior to shipment.

The packaging sequence is as follows:

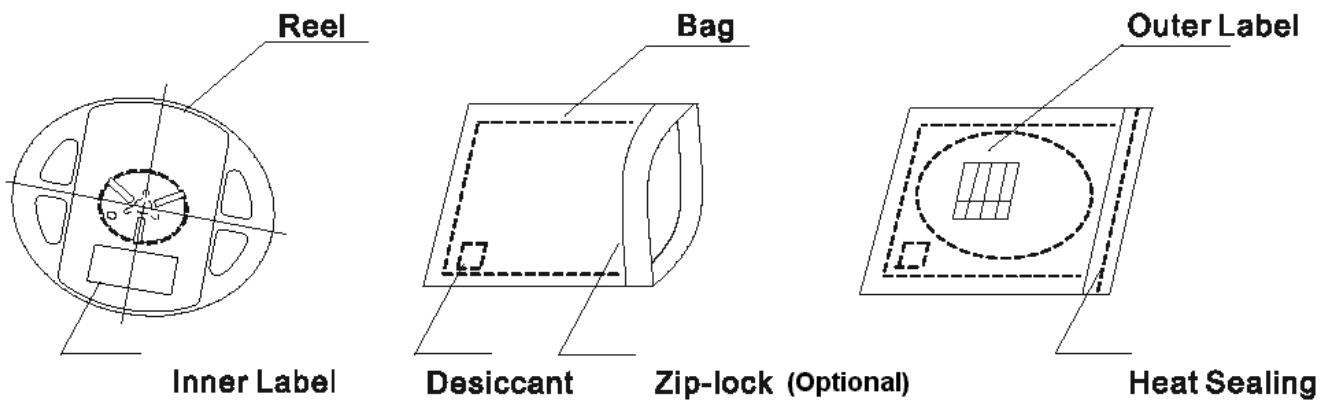

Reflow Soldering

- Recommended tin glue specifications: melting temperature in the range of 178~192 °C
- The recommended reflow soldering profile is as follows (temperatures indicated are as measured on the surface of the LED resin):

Lead-free Solder Profile

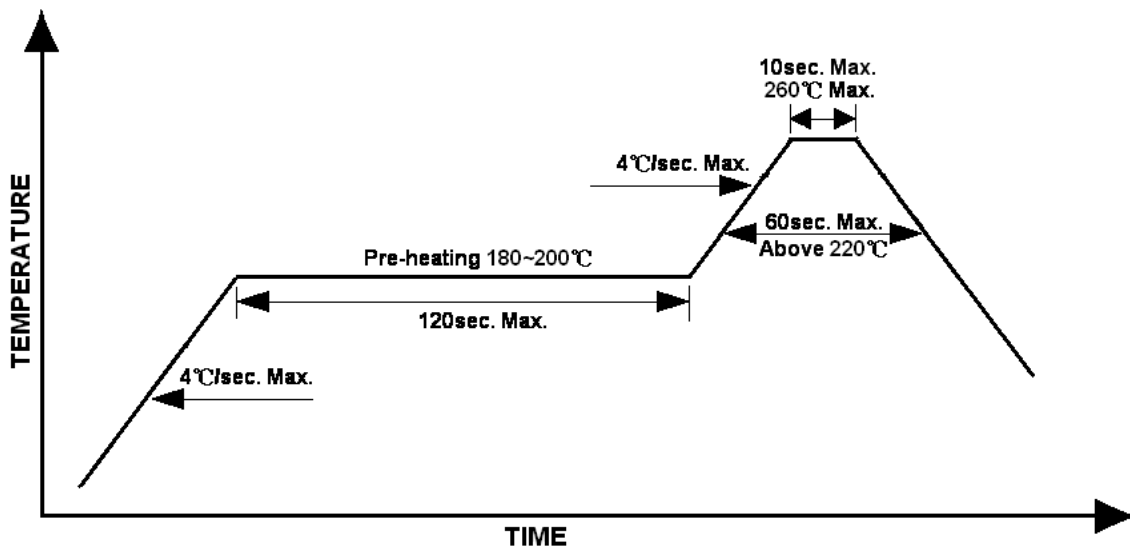

Precautions

- Avoid exposure to moisture at all times during transportation or storage.
- Anti-Static precaution must be taken when handling GaN, InGaN, and AlInGaP products.
- It is suggested to connect the unit with a current limiting resistor of the proper size. Avoid applying a reverse voltage.
- Avoid operation beyond the limits as specified by the absolute maximum ratings.
- Avoid direct contact with the surface through which the LED emits light.
- If possible, assemble the unit in a clean room or dust-free environment.

Reworking

- Rework should be completed within 5 seconds under 260 °C.
- The iron tip must not come in contact with the copper foil.
- Twin-head type is preferred.

Cleaning

Following are cleaning procedures after soldering:

- An alcohol-based solvent such as isopropyl alcohol (IPA) is recommended.
- Temperature x Time should be 50°C x 30sec. or <30°C x 3min
- Ultra sonic cleaning: < 15W/ bath; bath volume ≤ 1liter
- Curing: 100 °C max, <3min

Cautions of Pick and Place

- Avoid stress on the resin at elevated temperature.
- Avoid rubbing or scraping the resin by any object.
- Electro-static may cause damage to the component. Please ensure that the equipment is properly grounded. Use of an ionizer fan is recommended.

Revision History

Changes since last revision	Page	Version No.	Revision Date
Initial Release		V1.0	04-02-2020

DISCLAIMER

INOLUX reserves the right to make changes without further notice to any products herein to improve reliability, function or design. INOLUX does not assume any liability arising out of the application or use of any product or circuit described herein; neither does it convey any license under its patent rights, nor the rights of others.

LIFE SUPPORT POLICY

INOLUX's products are not authorized for use as critical components in life support devices or systems without the express written approval of the President of INOLUX or INOLUX CORPORATION. As used herein:

1. Life support devices or systems are devices or systems which, (a) are intended for surgical implant into the body, or (b) support or sustain life, and (c) whose failure to perform when properly used in accordance with instructions for use provided in the labeling, can be reasonably expected to result in a significant injury of the user.
2. A critical component in any component of a life support device or system whose failure to perform can be reasonably expected to cause the failure of the life support device or system, or to affect its safety or effectiveness.