

LOC	DIST	REVISIONS			
GP	00	REV	DATE	DWN	APVD
		A	RELEASE PER ECO-10-025263	14FEB2011	CJV JTJ

- 1 MATERIAL:
 CAGE ASSEMBLY: NICKEL SILVER ALLOY
 GASKET RETENTION PLATE AND LIGHT PIPE BRACKET: STAINLESS STEEL
 EMI GASKET: PLATED FILLED SILICONE
 LIGHT PIPE: POLYCARBONATE, CLEAR.
- 2 DATUM AND BASIC DIMENSION ESTABLISHED BY CUSTOMER.
- 3. MATES WITH SFP MSA COMPLIANT TRANSCEIVERS.
- 4 PADS AND VIAS CHASSIS GROUND.
- 5. INTERPRETATION OF DATUM REFERENCE FRAME IN ACCORDANCE WITH SECT 4.4.1.1 OF ASME Y14.5M-1994.
- 6 MINIMUM PC BOARD THICKNESS:
 SINGLE SIDED: 1.45mm.
- 7 HOLE PATTERN REPEATS FOR EACH PORT, SPACING BETWEEN PORTS IS 14.25mm.
- 8 REFERENCE APPLICATION SPEC 114-13120, HOLE A, FOR RECOMMENDED DRILL HOLE DIAMETER AND PLATING THICKNESS.
- 9 REFERENCE APPLICATION SPEC 114-13120, HOLE B, FOR RECOMMENDED DRILL HOLE DIAMETER AND PLATING THICKNESS.
- 10 LIGHT PIPE ASSEMBLY SHIPPED UNASSEMBLED TO CAGE ASSEMBLY, CAGE ASSEMBLY TO BE PRESSED INTO THE PC BOARD PRIOR TO ATTACHING THE LIGHT PIPE ASSEMBLY TO THE CAGE ASSEMBLY.

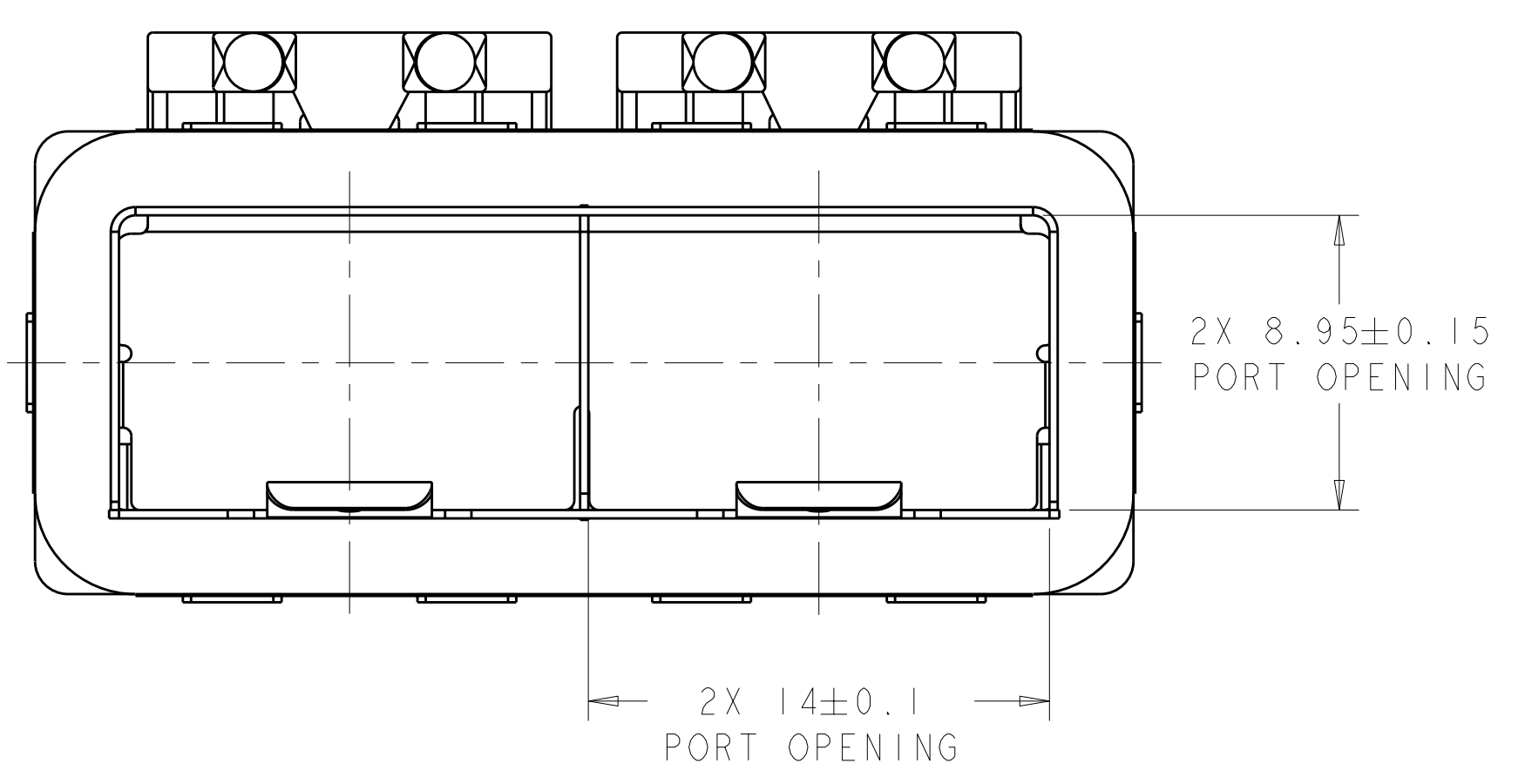
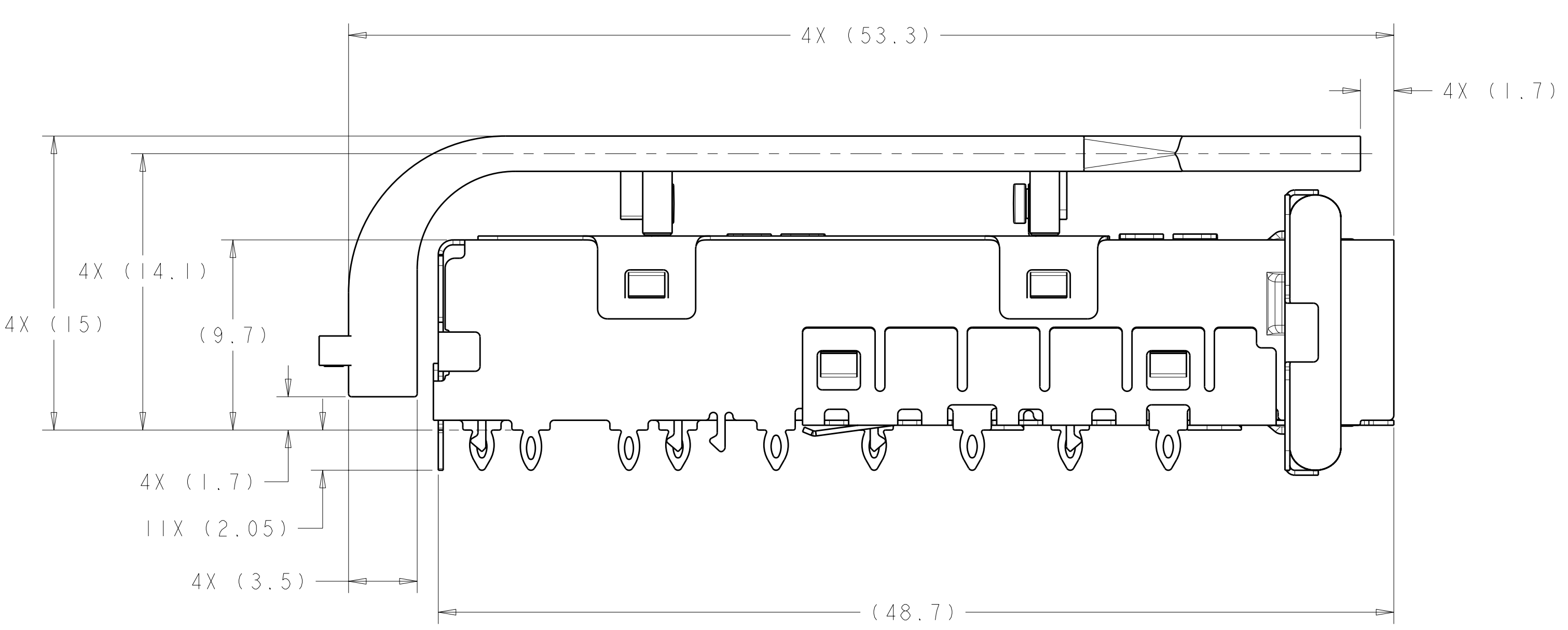
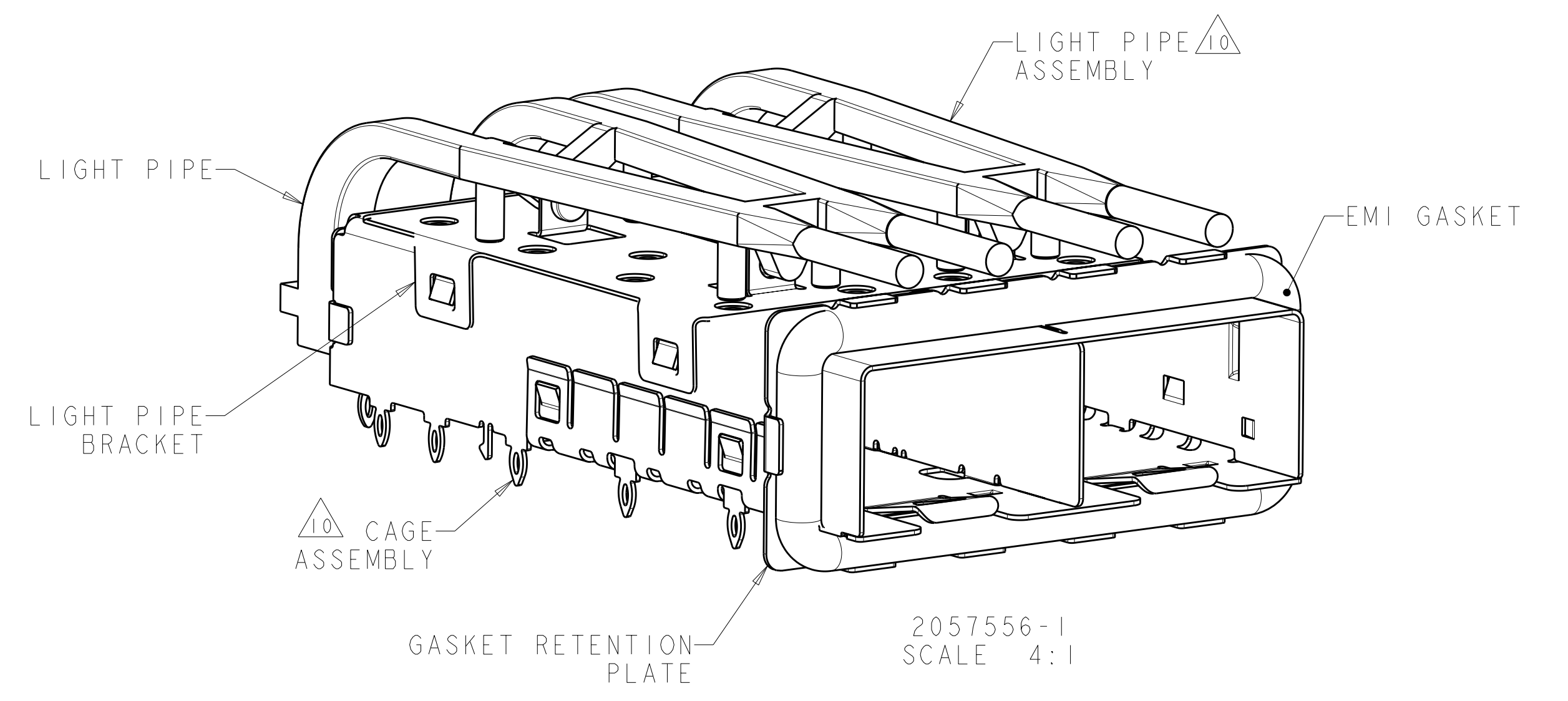
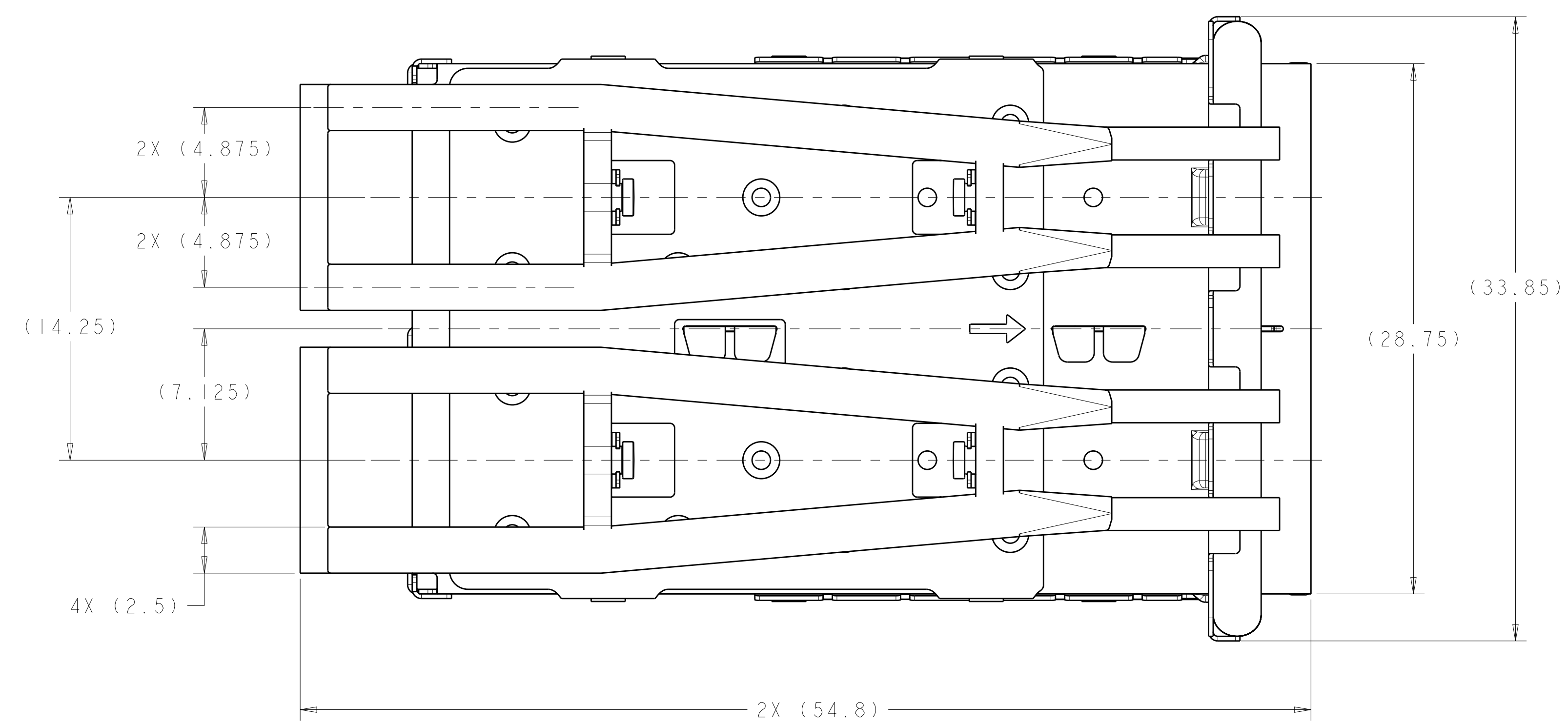

2057556-1
PART NUMBER

DIMENSIONS: mm 		TOLERANCES UNLESS OTHERWISE SPECIFIED: 9 PLC ±0.13 1 PLC ±0.1 2 PLC ±0.08 3 PLC ±0.05 4 PLC ±0.05 ANGLES ±0.05 FINISH #1		DWN B. MCMASTER 06OCT08 CHK M. SCHMITT 06OCT08 APVD M. SCHMITT 06OCT08		Tyco Electronics Harrisburg, PA 17105-3608	
MATERIAL 		CUSTOMER DRAWING		NAME SFP+ 1X2 CAGE ASSEMBLY WITH LIGHT PIPES, PRESS FIT, EMI GASKET		SIZE CAGE CODE DRAWING NO 114-13120	
		WEIGHT -		A 100779 C=2057556		RESTRICTED TO -	
		SCALE 5:1		SHEET 1 OF 3		REV A	

LOC	DIST	REVISIONS					
GP	00	P	LTR	DESCRIPTION	DATE	DWN	APVD
-	-	-	-	SEE SHEET 1	-	-	-

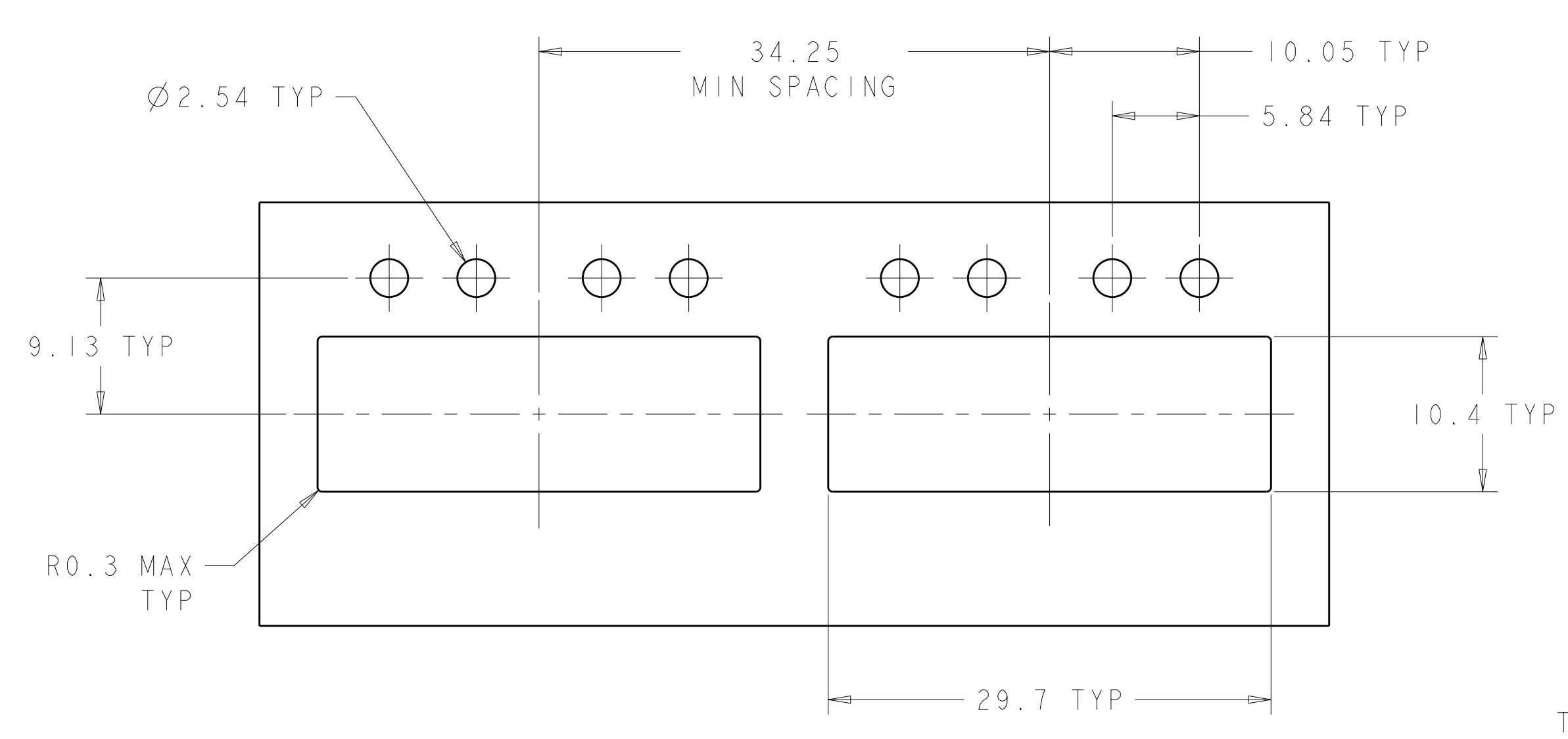

RECOMMENDED BEZEL CUT-OUT
 SCALE 3:1

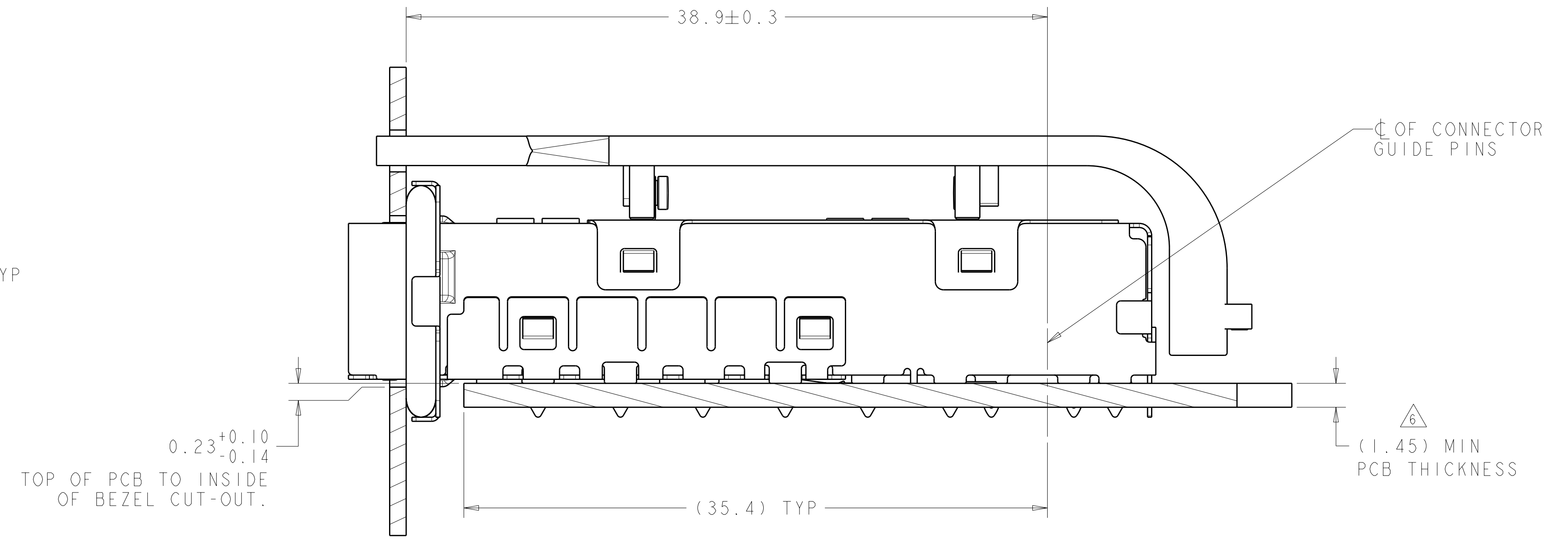

SECTION J-J
 MOUNTED ON PCB
 SHOWN THRU RECOMMENDED BEZEL

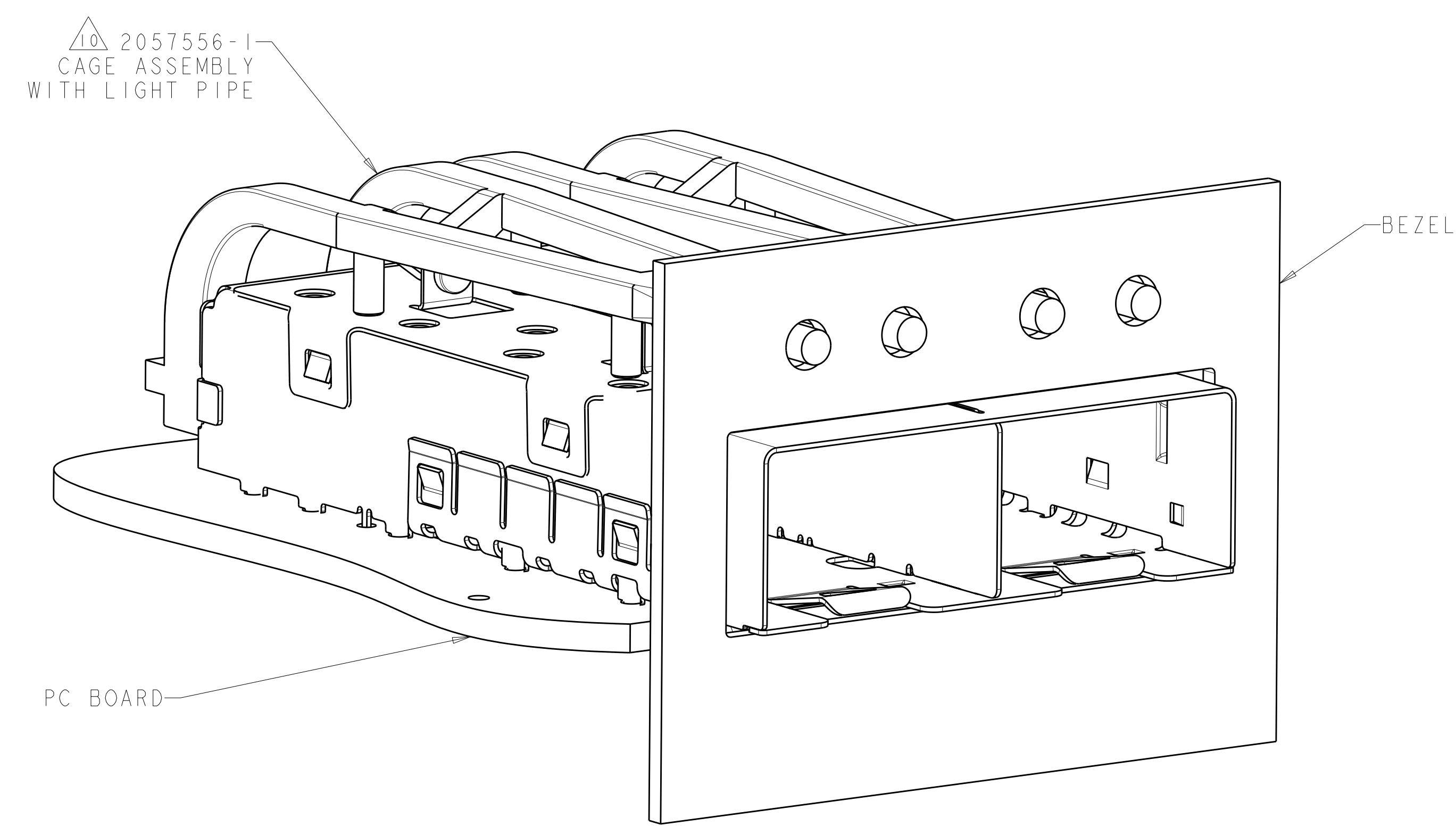

2057556-1
 MOUNTED ON PCB
 SHOWN THRU RECOMMENDED BEZEL.

DIMENSIONS:		TOLERANCES UNLESS OTHERWISE SPECIFIED:		DWN B. MCMASTER 06OCT08		Tyco Electronics	
mm	9 PLC ±0.13	1 PLC ±0.1	2 PLC ±0.08	3 PLC ±0.05	4 PLC ±0.05	114-13120	114-13120
	ANGLES ±0.05	FINISH #1					
MATERIAL							
CUSTOMER DRAWING				SCALE 5:1		SHEET 2 OF 3	

LOC	DIST	REV	DATE	BY	APPD
GP	00				

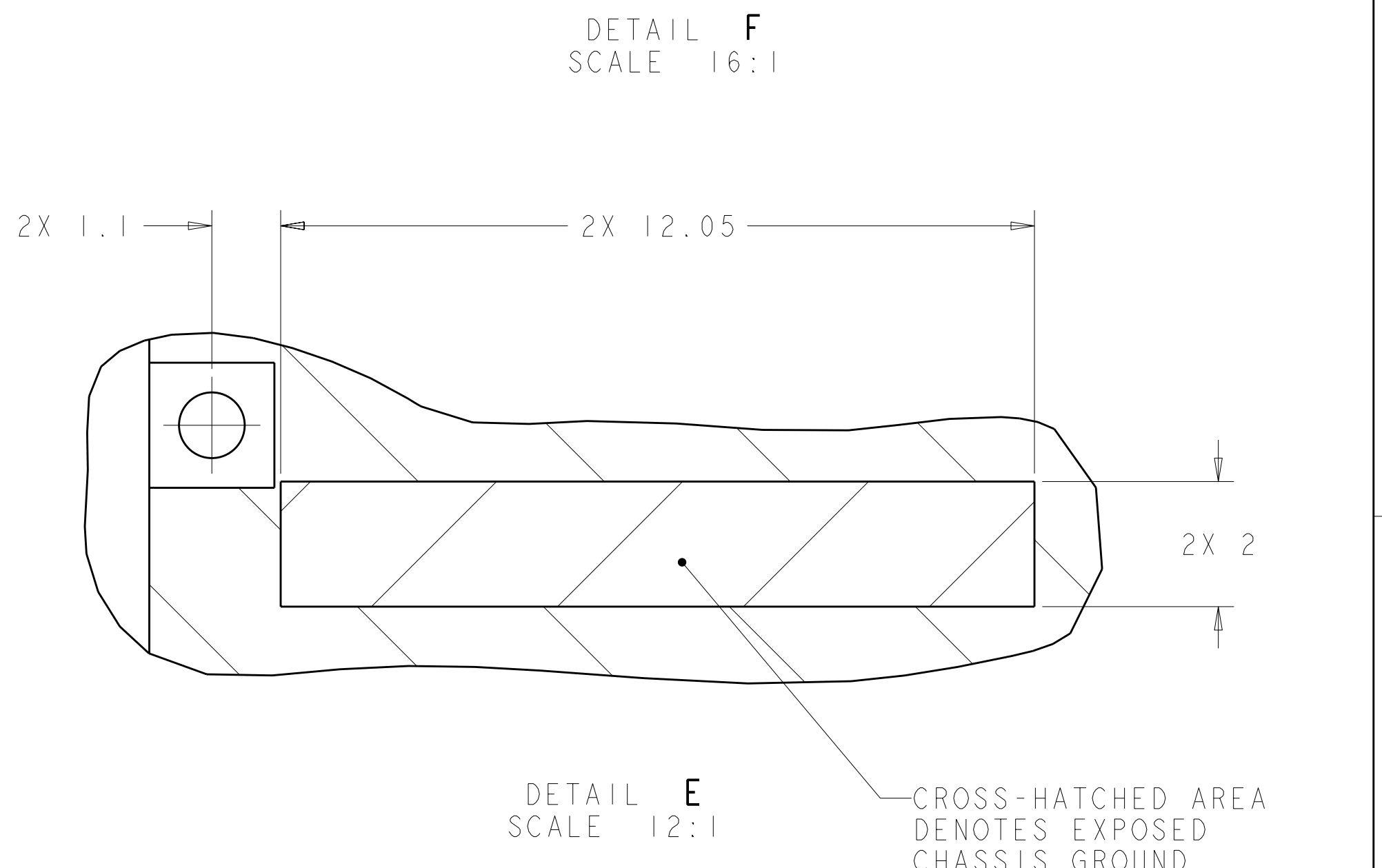
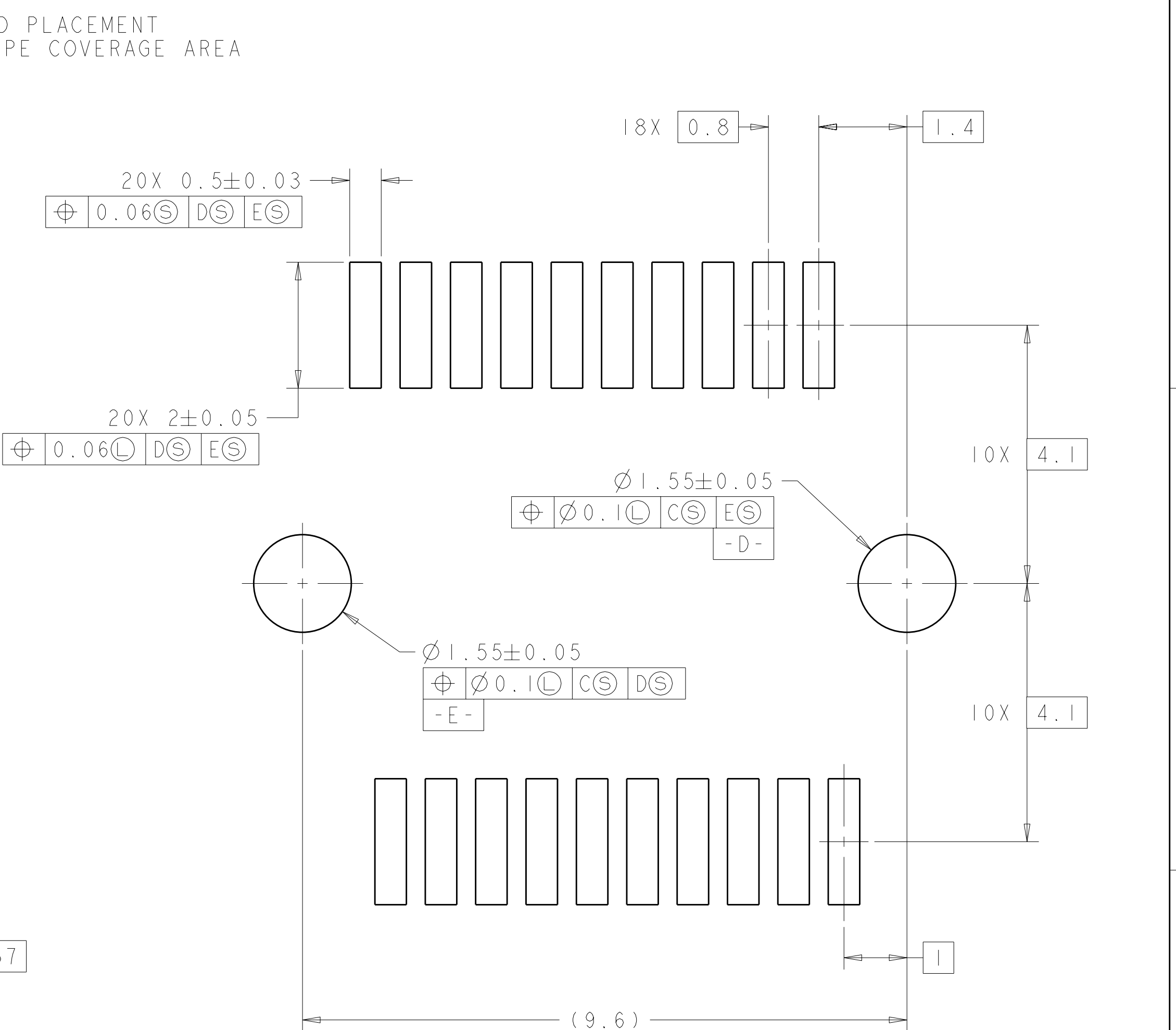
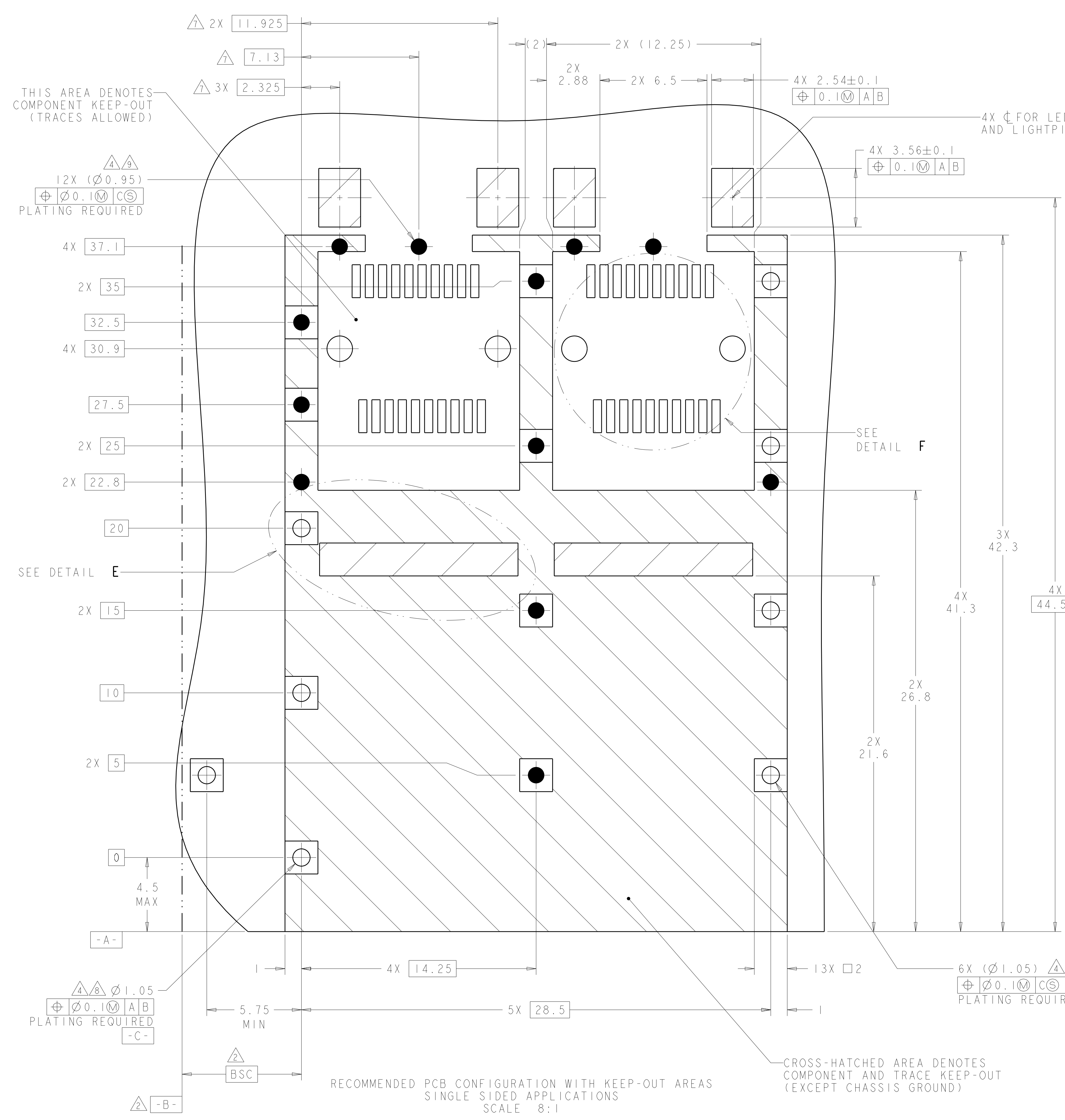

DIMENSIONS: mm 		TOLERANCES UNLESS OTHERWISE SPECIFIED: 9 PLC ±0.13 1 PLC ±0.1 5 PLC ±0.08 4 PLC ±0.05 ANGLES ±0.05		DWN ID: MCMASPER 06OCT08 CHY M SCHMITT 06OCT08 APVD M SCHMITT 06OCT08		Tyco Electronics Harrisburg, PA 17105-3608	
MATERIAL: FINISH: #1		PRODUCT SPEC: 114-13120 APPLICATION SPEC: 114-13120 WEIGHT:		NAME: SFP+ 1X2 CAGE ASSEMBLY WITH LIGHT PIPES, PRESS FIT, EMI GASKET		SIZE: CAGE CODE DRAWING NO: A100779C=2057556 RESTRICTED TO:	
CUSTOMER DRAWING		SCALE: 5:1		SHEET: 3 OF 3		REV: A	