

PART NUMBER	REV	FIRST USED
466901-1	AB	854040-3
7-466901-7	AA	-

TERMINAL NAME:  
20 DF CONTACT

PIN	SOCKET
66507	66505
	745502

TERM APPL SPEC 114-10000

CRIMPING DATA

VISIBLE PAD LTR	CRIMP HEIGHT	WIRE SIZE	
A	NOT	USED	
B	.026±.001	28	
C	.032±.001	24	
D	.030±.001	26	
CRIMP	SIZE	TYPE	RANGE
WIRE	.042	F	28-24 $\Delta$ 4
INSUL	.055	0	.030-.040
FEED	APPL INST	SET UP GAGE	LAYOUT
.300	$\Delta$ 1-	-	646
WIRE STRIP LENGTH .084-.104			

LOC	DIST	REV	DESCRIPTION	DATE	OWN	APVD
A	66	AB	ECR-08-000264	-	-	-

SIM TO HDM 466423

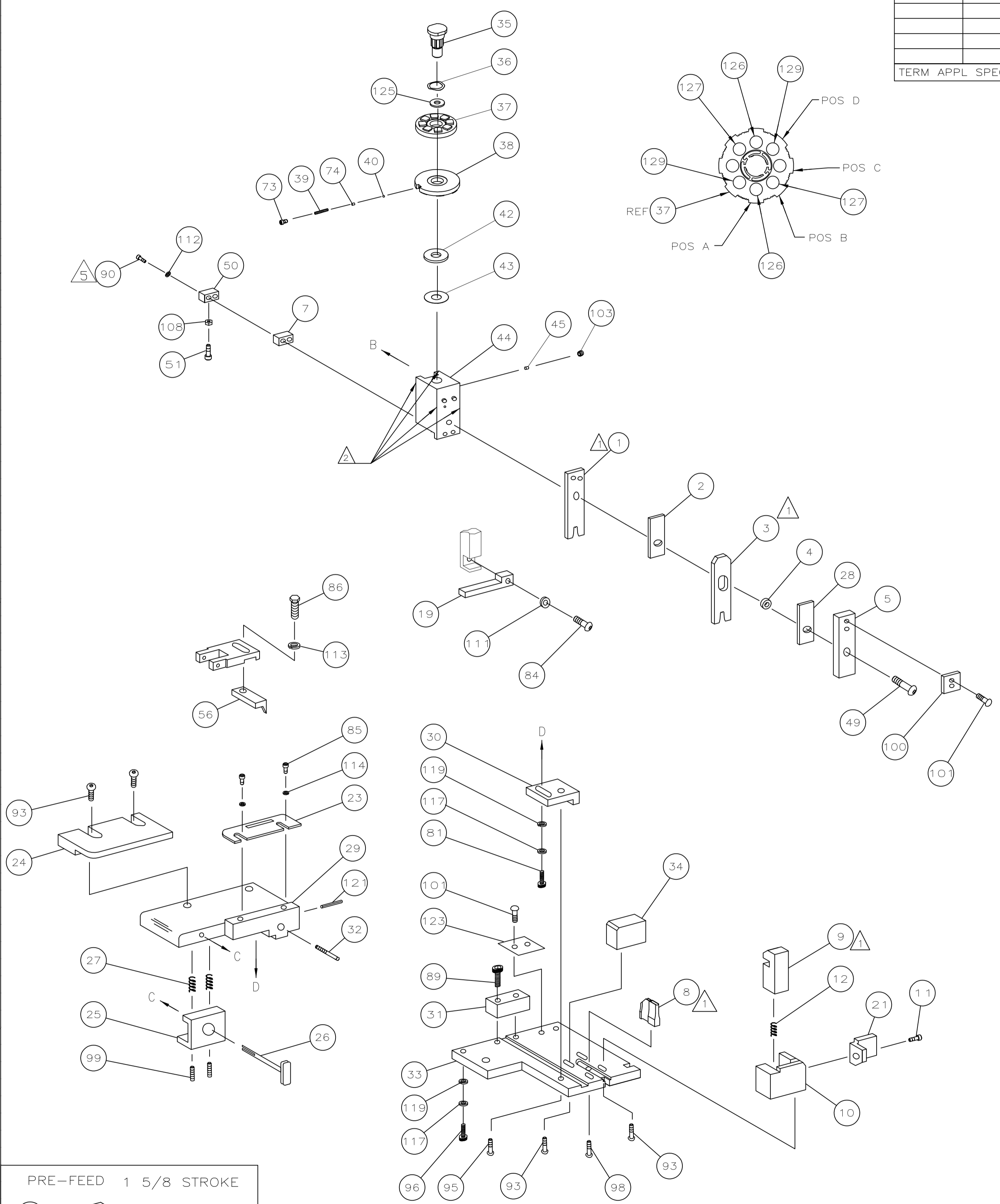

QTY	REQD	PER	ASSY	PART NO	DESCRIPTION	ITEM NO
-	2	-		7-354779-0	PIN, WIRE DISC (.3340)D	129
-	2	-				128
-	2	-		6-354779-2	PIN, WIRE DISC (.3300)B	127
-	2	-		5-354779-8	PIN, WIRE DISC (.3280)A	126
-	1	-		986950-1	WASHER, FLAT PRECISION	125
-	1	-		690701-2	PLATE, SERIAL NO.	124
-	1	-		4-21028-0	PIN,SLT SPR( $\phi$ .093x.75)ST GDE PL	123
-	2	-		21899-2	WASHER,FLAT(#10)S G ADJ BLK	122
-	2	-		21024-5	WASHER, LOCK(#10)ADJ BLOCK	121
-	2	-		21024-2	WASHER,LOCK(#4)FRONT STP GUIDE	120
-	REF	-		21024-4	WASHER,LOCK(#8)FEED FINGER	119
-	2	-		21024-4	WASHER,LOCK(#8)DEP-HOLD	118
-	REF	-		21024-4	WASHER,LOCK(#8)STRIPPER	117
-	1	-		21018-5	NUT,HEX(#6)HOLD DOWN	116
-	2	-		21024-2	WASHER,LOCK(#4)FRONT STP GUIDE	115
-	REF	-		21024-4	WASHER,LOCK(#8)FEED FINGER	114
-	2	-		21024-4	WASHER,LOCK(#8)DEP-HOLD	113
-	REF	-		21024-4	WASHER,LOCK(#8)STRIPPER	112
-	1	-		21018-5	NUT,HEX(#6)HOLD DOWN	111
-	1	-		21009-2	SCR,SKT SET(1/4-20x.25 LW)RAM	110
-	4	-		21017-2	SCR,DRIVE(#2x.19)ID PLATE	109
-	1	-		819347-1	PLATE, IDENTIFICATION	108
-	2	-		5-21006-6	SCR,SET(10-32x.75)DRAG	107
-	1	-		22733-8	SCR,BHC(8-32x.38 LW)ANVIL	106
-	1	-		3-21000-8	SCR,SHC(10-32x.88)MOUNTING	105
-	1	-		2-21002-7	SCR, BHC, 10-32 x .50	104
-	4	-		22733-9	SCR,BHC(8-32x.50)SHEAR-TERM SUP	103
-	6	-		2-21002-2	SCR,BHC(8-32x.50)R STP GDE	102
-	1	-		1-21002-7	SCR,SHC(6-32x.50)CAM	101
-	2	-		2-21000-8	SCR,SHC(8-32x.62)SCR BLK	100
-	2	-		2-21000-7	SCR,SHC(8-32x.50)	99
-	REF	-		2-22603-0	SCR,HEX HD(8-32x.31)FEED FINGER	98
-	2	-		1-21000-3	SCR,SHC(4-40x.25)F ST GUIDE	97
-	REF	-		22733-9	SCR,BHC(8-32x.50 SL)STRIPPER	96
-	1	-		3-22603-1	SCR, HEX HD, (10-32x.38)SG ADJ BL	95
-	2	-		463310-8	BLADE, STRIPPING (#26)	94
-	1	-		690603-1	SPRING, ASSIST	93
-	1	-		23030-1	SCR,SKT CAP(6-32x.25)CP DSC	92
-	3	-				91
-	2	-				90
-	1	-				89
-	1	-				88
-	1	-				87
-	1	-				86
-	2	-				85
-	1	-				84
-	1	-				83
-	1	-				82
-	1	-				81
-	1	-				80
-	1	-				79
-	1	-				78
-	2	-				77
-	1	-				76
-	1	-				75
-	1	-				74
-	1	-				73
-	1	-				72
-	1	-				71
-	3	-				70

QTY	REQD	PER	ASSY	PART NO	DESCRIPTION	ITEM NO
-	REF	-		694433-8	PAWL, FEED	56
-	1	-		811242-2	BUMPER, HOLDDOWN	55
-	1	-		690753-1	SPACER, TONKER	54
-	1	-		7-21002-9	BOLT, CRIMPER(5/16x1.00)	53
-	1	-		690602-6	CAM, PRE-FEED 1.62 STROKE	52
-	1	-		690191-1	PLUG, NYLON	51
-	1	-		455673-3	RAM	50
-	1	-		690125-1	WASHER, LAMINATED	49
-	1	-		690124-1	WASHER, RAM	48
-	1	-		23241-6	BALL, STEEL	47
-	1	-		690170-1	SPRING, COMPRESSION	46
-	1	-		690142-1	DISC, INSULATION	45
-	1	-		354777-1	WIRE DISC, PLASTIC	44
-	1	-		22480-5	WASHER, SPRING	43
-	1	-		690212-1	POST, RAM	42
-	1	-		692776-2	SUPPORT, TERMINAL	41
-	1	-		462544-1	PLATE, BASE SPECIAL	40
-	1	-		690432-3	SCREW, ADJUSTMENT	39
-	1	-		462543-1	BLOCK, SCREW SPECIAL	38
-	1	-		455689-1	BLOCK, STRIP GUIDE ADJ	37
-	1	-		455671-8	PLATE, STRIP GUIDE	36
-	1	-		455888-8	SPACER, FRONT SHEAR DEP	35
-	2	-		1-22282-3	SPRING, DRAG	34
-	1	-		690546-1	LEVER, DRAG RELEASE	33
-	1	-		240792-1	DRAG, TERMINAL	32
-	1	-		6-690504-3	GUIDE, STRIP (REAR)	31
-	1	-		690438-1	GUIDE, STRIP (FRONT)	30
-	1	-		463756-1	GUIDE, SCRAP	29
-	REF	-		462615-1	STRIPPER	28
-	1	-		3-22280-3	SPRING, SHEAR	27
-	1	-		690461-2	STOP, SHEAR (FRONT)	26
-	1	-		462548-2	HOLDER, SHEAR (FRONT) SP	25
-	1	-		462547-1	SHEAR, FLOAT (FRONT) SP	24
1	1	-		4-458834-9	ANVIL	23
-	1	-		3-240641-9	SPACER, DEPRESSOR	22
-	1	-		462838-4	DEPRESSOR, SHEAR (FRONT) SP	21
-	1	-		2-238011-3	SPACER, BLOCK CRIMPER	20
1	1	-		5-456135-8	CRIMPER, INSULATION	19
-	1	-		455888-1	SPACER, CRIMPER	18
1	1	-		456401-5	CRIMPER, WIRE	17

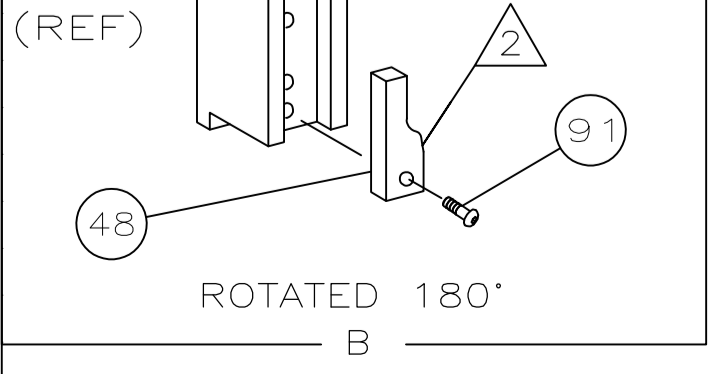

- $\Delta$ 1 RECOMMENDED SPARE PARTS.
- $\Delta$ 2 GREASE LIGHTLY.
- $\Delta$ 3 ITEM NOT SHOWN
- $\Delta$ 4 WIRE SIZE #24 ONLY WHEN APPROVED BY APPL ENGINEERING.
- $\Delta$ 5 CUT TO LENGTH AT ASSEMBLY

THIS DRAWING IS A CONTROLLED DOCUMENT.

DIMENSIONS: INCHES	TOLERANCES UNLESS OTHERWISE SPECIFIED:	DATE: 8/18/93	BY: D.SALTZER	REV: 8-24-93	APPROVED: E.KOOTIE	NAME: STRIPPER CRIMPER APPLICATOR
0 PLC ± .005	1 PLC ± .002	2 PLC ± .001	3 PLC ± .0005	4 PLC ± .0002	ANGLES ± .001	FINISH
MATERIAL	FINISH	WEIGHT	SIZE: A1	CAGE CODE: 00779	DRAWING NO: 466901	RESTRICTED TO: -
CUSTOMER DRAWING			SCALE: -	SHEET: 1 OF 1	REV: AB	

Tyco Electronics Corporation  
Harrisburg, PA 17105-3608