

ISL24211

Programmable V_{COM} Calibrator with EEPROM and Output Buffer

FN7585
Rev 0.00
February 23, 2011

The ISL24211 is an 8-bit programmable current sink that can be used in conjunction with an external voltage divider to generate a voltage source (V_{COM}) positioned between the analog supply voltage and ground. The current sink's full-scale range is controlled by an external resistor, R_{SET} . With the appropriate choice of external resistors R_1 and R_2 , the V_{COM} voltage range can be controlled between any arbitrary voltage range. The ISL24211 has an 8-bit data register and 8-bit EEPROM for storing both a volatile and a permanent value for its output, with an I²C interface to read and write to the register and EEPROM. After the part is programmed, the I²C interface is no longer needed; on power-up the EEPROM contents are automatically transferred to the data register, and the pre-programmed output voltage appears on the V_{COM_OUT} pin.

The ISL24211 also features an integrated, wide-bandwidth, high output drive buffer amplifier that can directly drive the V_{COM} input of an LCD panel.

The ISL24211 is available in an 10 Ld 3mm x 3mm TDFN package. This package has a maximum height of 0.8mm for very low profile designs. The ambient operating temperature range is -40°C to +85°C.

Features

- 8-bit, 256-Step, Adjustable Sink Current Output
- 60MHz V_{COM} Buffer/Amplifier
- 4.5V to 19.0V Analog Supply Range for Normal Operation (10.8V Minimum Analog Supply Voltage for Programming)
- 2.25V to 3.6V Logic Supply Voltage Operating Range
- 400kHz, I²C Interface
- On-Chip 8-Bit EEPROM
- Guaranteed Monotonic Over-Temperature
- Compatible with applications using the 7-bit ISL45041
- Pb-free (RoHS-compliant)
- Ultra-Thin 10 Ld TDFN (3 x 3 x 0.8mm max)

Applications

- LCD Panel V_{COM} Generator
- Electrophoretic Display V_{COM} Generator

Related Literature

- AN1627 "ISL24211IRTZ-EVALZ Evaluation Board User Guide"

Typical Application

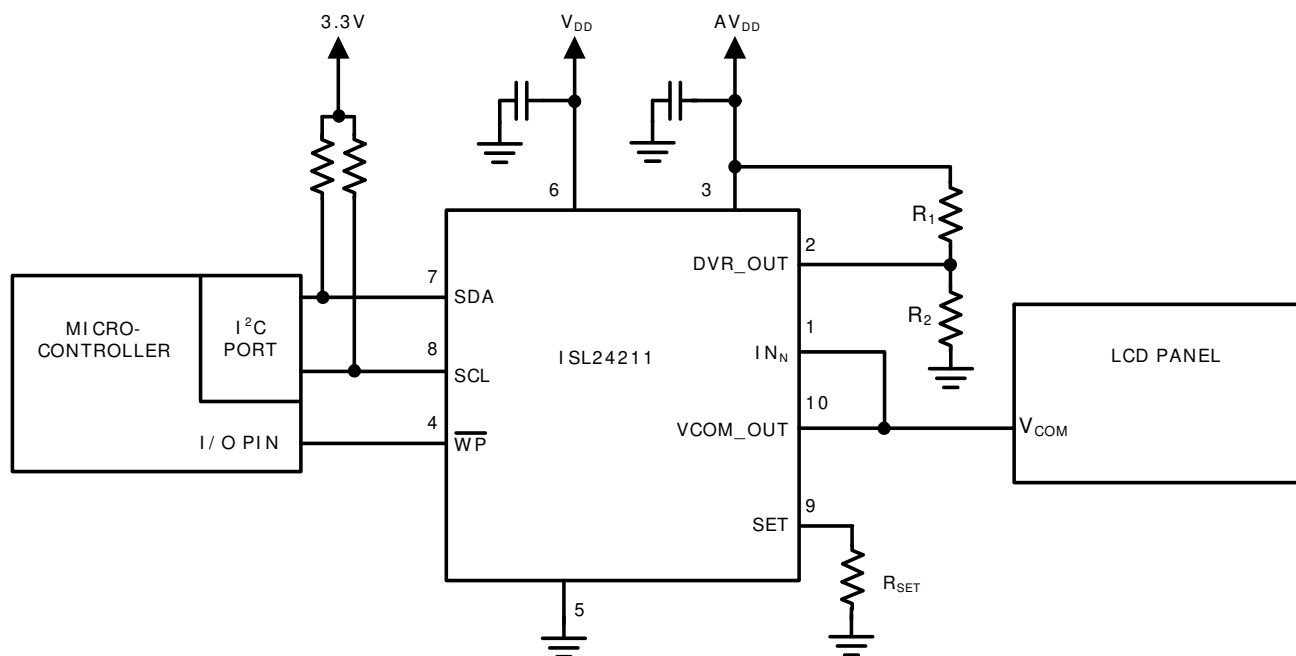

FIGURE 1. TYPICAL ISL24211 APPLICATION

Block Diagram

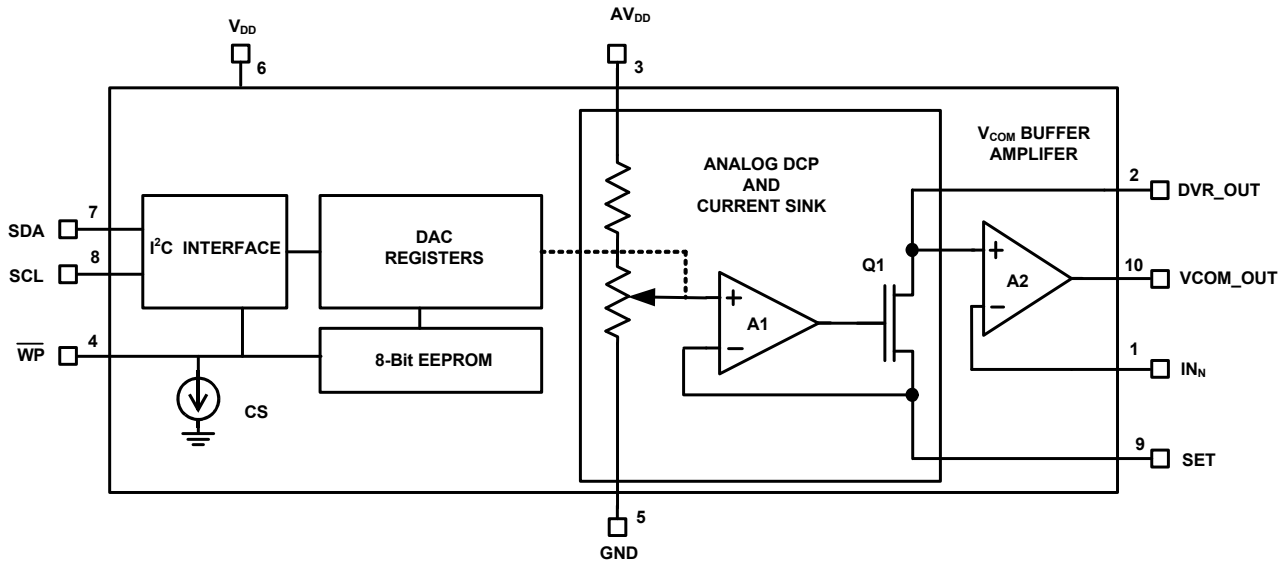
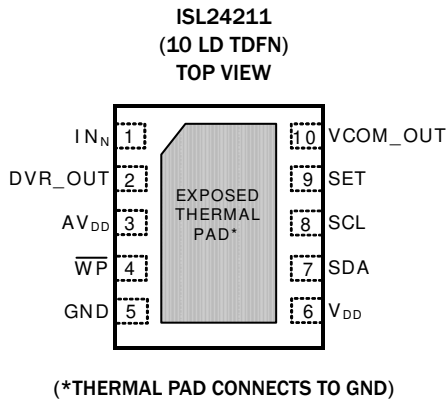

FIGURE 2. BLOCK DIAGRAM OF THE ISL24211

Pin Configuration



Pin Descriptions

PIN NAME	PIN NUMBER	FUNCTION
IN _N	1	Negative (inverting) input of the V _{COM} buffer op amp. This pin is used to provide feedback from the end point of the V _{COM} trace.
DVR_OUT	2	Adjustable Sink Current Output Pin. The current sunk into the DVR_OUT pin is equal to the DAC setting times the maximum adjustable sink current divided by 256. See the "SET" pin function description below (pin 9) for the maximum adjustable sink current setting. Also tied to the non-inverting input of buffer amp.
AV _{DD}	3	Analog Power Supply Input. Bypass to GND with 0.1μF capacitor.
WP	4	EEPROM Write Protect. Active Low. 0 = Programming disabled; 1 = Programming allowed.
GND	5	Ground connection.
V _{DD}	6	Digital power supply input. Bypass to GND with 0.1μF capacitor.
SDA	7	I ² C Serial Data Input
SCL	8	I ² C Clock Input
SET	9	Maximum Sink Current Adjustment Point. Connect a resistor from SET to GND to set the maximum adjustable sink current of the DVR_OUT pin. The maximum adjustable sink current is equal to (AV _{DD} /20) divided by R _{SET} .
VCOM_OUT	10	Output of the buffer amplifier
PAD	-	Thermal pad should be connected to system ground plane to optimize thermal performance.

Ordering Information

PART NUMBER (Notes 1, 2, 3)	PART MARKING	INTERFACE	TEMP RANGE (°C)	PACKAGE (Pb-Free)	PKG. DWG. #
ISL24211IRTZ	211Z	I ² C	-40 to +85	10 Ld 3x3 TDFN	L10.3x3A
ISL24211IRTZ-EVALZ	Evaluation Board				

NOTES:

1. Add "-T*" suffix for tape and reel. Please refer to [TB347](#) for details on reel specifications.
2. These Intersil Pb-free plastic packaged products employ special Pb-free material sets, molding compounds/die attach materials, and 100% matte tin plate plus anneal (e3 termination finish, which is RoHS compliant and compatible with both SnPb and Pb-free soldering operations). Intersil Pb-free products are MSL classified at Pb-free peak reflow temperatures that meet or exceed the Pb-free requirements of IPC/JEDEC J STD-020.
3. For Moisture Sensitivity Level (MSL), please see device information page [ISL24211](#). For more information on MSL please see techbrief [TB363](#).

Absolute Maximum Ratings

Supply Voltage	
AV _{DD} to GND	20V
V _{DD} to GND	4V
Input Voltage with respect to Ground	
SET, IN _N	4V
SCL, SDA and \overline{WP}	V _{DD} + 0.3V
Output Voltage with respect to Ground	
DVR_OUT, VCOM_OUT	AV _{DD}
Continuous Output Current	
DVR_OUT	5mA
VCOM_OUT	±100mA
ESD Ratings	
Human Body Model (Tested per JESD22-A114)	7kV
Machine Model (Tested per JESD22-A115)	300V
Charged Device Model (Tested per JESD22-C101)	2kV
Latch Up (Tested per JESD 78, Class II, Level A)	100mA

Thermal Information

Thermal Resistance (Typical)	θ_{JA} (°C/W)	θ_{JC} (°C/W)
10 Ld TDFN Package (Notes 4, 5)	53	11
Moisture Sensitivity (see Technical Brief TB363)		
All Packages	Level 1	
Maximum Die Temperature	+150°C	
Storage Temperature	-65°C to +150°C	
Pb-free Reflow Profile	see link below	
	http://www.intersil.com/pbfree/Pb-FreeReflow.asp	

Recommended Operating Conditions

Operating Range	
AV _{DD}	4.5V to 19V
V _{DD}	2.25V to 3.6V
Ambient Operating Temperature	-40°C to +85°C

CAUTION: Do not operate at or near the maximum ratings listed for extended periods of time. Exposure to such conditions may adversely impact product reliability and result in failures not covered by warranty.

NOTES:

- θ_{JA} is measured in free air with the component mounted on a high effective thermal conductivity test board with "direct attach" features. See Tech Brief TB379.
- For θ_{JC} , the "case temp" location is the center of the exposed metal pad on the package underside.

Electrical Specifications Test Conditions: V_{DD} = 3.3V, AV_{DD} = 18V, R_{SET} = 5k Ω , R₁ = 10k Ω , R₂ = 10k Ω , (See Figure 5), V_{COM_OUT} pin connected to IN_N, unless otherwise specified. Typicals are at T_A = +25°C. **Boldface limits apply over the operating temperature range, -40°C to +85°C.**

SYMBOL	PARAMETER	TEST CONDITIONS	MIN (Note 6)	TYP	MAX (Note 6)	UNITS
DC CHARACTERISTICS						
V _{DD}	V _{DD} Supply Range - Operating		2.25		3.6	V
AV _{DD}	AV _{DD} Supply Range Supporting EEPROM Programming		10.8		19	V
AV _{DD}	AV _{DD} Supply Range for Wide-Supply Operation (not supporting EEPROM Programming)		4.5		19	V
I _{DD}	V _{DD} Supply Current	$\overline{WP} = SCL = SDA = V_{DD}$		95	300	μ A
I _{AVDD}	AV _{DD} Supply Current	$\overline{WP} = SCL = SDA = V_{DD}$		3.8	6.5	mA
DVR_OUT CHARACTERISTICS						
ZSE _{SET}	SET Zero-Scale Error				±3	LSB
FSE _{SET}	SET Full-Scale Error				±8	LSB
TCV _{SET}	SET Voltage Drift			7		μ V/°C
V _{DVR_OUT}	DVR_OUT Voltage Range	I _{DVR_OUT} < 0.5mA	V_{SET} + 0.4		AV_{DD}	V
I _{DVR_OUT}	Maximum DVR_OUT Sink Current			4		mA
INL	Integral Non-Linearity				±2	LSB
DNL	Differential Non-Linearity				±1	LSB
OUTPUT AMPLIFIER CHARACTERISTICS						
V _{OS}	Input Offset Voltage			±2	±15	mV
TCV _{OS}	Input Offset Voltage Drift			-6.3		μ V/°C
I _B	Input Bias Current			0.001	±1	μ A
CMRR	Common-Mode Rejection Ratio		55	75		dB
PSRR	Power Supply Rejection Ratio		60	82		dB
A _{VOL}	Open Loop Gain		55	75		dB
V _{OL}	Output Swing Low	I _L = -5mA		50	150	mV

Electrical Specifications Test Conditions: $V_{DD} = 3.3V$, $AV_{DD} = 18V$, $R_{SET} = 5k\Omega$, $R_1 = 10k\Omega$, $R_2 = 10k\Omega$, (See Figure 5), V_{COM_OUT} pin connected to IN_N , unless otherwise specified. Typical values are at $T_A = +25^\circ C$. **Boldface limits apply over the operating temperature range, $-40^\circ C$ to $+85^\circ C$.** (Continued)

SYMBOL	PARAMETER	TEST CONDITIONS	MIN (Note 6)	TYP	MAX (Note 6)	UNITS
V_{OH}	Output Swing High	$I_L = 5mA$	17.85	17.9		V
I_{SC}	Short Circuit Current (Sinking)		300	430		mA
	Short Circuit Current (Sourcing)		450	555		mA
SR	Slew Rate (Rising)	1k Ω 8pF Load	70	116		V/ μs
	Slew Rate (Falling)	1k Ω 8pF Load	50	93		V/ μs
t_s	Settling Time to 0.2%			150		ns
BW	-3dB Bandwidth			60		MHz
I²C INPUTS AND OUTPUT						
V_{IH_I2C}	SDA, SCL Logic 1 Input Voltage		1.44			V
V_{IL_I2C}	SDA, SCL Logic 0 Input Voltage				0.55	V
V_{HYS_I2C}	SDA, SCL Hysteresis			260		mV
I_{L_I2C}	SDA, SCL Input Leakage Current				± 1	μA
V_{OL_I2C}	SDA Output Logic Low	$I = -3mA$			0.4	V
V_{IH_WP}	\overline{WP} Input Logic High		0.7V_{DD}			V
V_{IL_WP}	\overline{WP} Input Logic Low				0.3V_{DD}	V
V_{HYS_WP}	\overline{WP} Input Hysteresis			260		mV
I_{L_WP}	\overline{WP} Input Leakage Current		-0.20	-0.5	-1	μA
I²C TIMING						
f_{CLK}	I ² C Clock Frequency				400	kHz
t_{SCH}	I ² C Clock High Time		0.6			μs
t_{SCL}	I ² C Clock Low Time		1.3			μs
t_{DSP}	I ² C Spike Rejection Filter Pulse Width		0		50	ns
t_{SDS}	I ² C Data Set Up Time		250			ns
t_{SDH}	I ² C Data Hold Time		250			ns
t_{BUF}	I ² C Time Between Stop and Start		200			μs
t_{STS}	I ² C Repeated Start Condition Set-up		0.6			μs
t_{STH}	I ² C Repeated Start Condition Hold		0.6			μs
t_{SPS}	I ² C Stop Condition Set-up		0.6			μs
C_{SDA}	SDA Pin Capacitance				10	pF
C_{SCL}	SCL Pin Capacitance				10	pF
t_{WR}	EEPROM Write Cycle Time				100	ms

NOTE:

6. Compliance to datasheet limits is assured by one or more methods: production test, characterization and/or design.

The maximum value of I_{DVR_OUT} can be calculated by substituting the maximum register value of 255 into Equation 2, resulting in Equation 3:

$$I_{DVR_OUT(MAX)} = \frac{AV_{DD}}{20R_{SET}} \quad (\text{EQ. 3})$$

Equation 2 can also be used to calculate the unit sink current step size per Register Code, resulting in Equation 4:

$$I_{STEP} = \frac{AV_{DD}}{(256)(20)(R_{SET})} \quad (\text{EQ. 4})$$

Determination of R_{SET}

The ultimate goal for the ISL24211 is to generate an adjustable voltage between two endpoints, V_{COM_MIN} and V_{COM_MAX} , with a fixed power supply voltage, AV_{DD} . This is accomplished by choosing the correct values for R_{SET} , R_1 and R_2 . The exact value of R_{SET} is not critical. Values from 1k to more than 100k will work under most conditions. The following expression calculates the minimum R_{SET} value:

$$R_{SET(MIN)} = \left(\frac{\frac{AV_{DD}}{16}}{\left(V_{OUT(MIN)} - \frac{AV_{DD}}{20} \right)} \right) (\text{k}\Omega) \quad (\text{EQ. 5})$$

Note that this is the absolute minimum value for R_{SET} . Larger R_{SET} values reduce quiescent power, since R_1 and R_2 are proportional to R_{SET} . The ISL24211 is tested with a 5k Ω R_{SET} .

Determination of R_1 and R_2

With AV_{DD} , $V_{COM(MIN)}$ and $V_{COM(MAX)}$ known and R_{SET} chosen per the above requirements, R_1 and R_2 can be determined using Equations 6 and 7:

$$R_1 = 5120 \cdot R_{SET} \left(\frac{V_{COM(MAX)} - V_{COM(MIN)}}{256 \cdot V_{COM(MAX)} - V_{COM(MIN)}} \right) \quad (\text{EQ. 6})$$

$$R_2 = 5120 \cdot R_{SET} \left(\frac{V_{COM(MAX)} - V_{COM(MIN)}}{255 \cdot AV_{DD} + V_{COM(MIN)} - 256 \cdot V_{COM(MAX)}} \right) \quad (\text{EQ. 7})$$

Final Transfer Function

The voltage at DVR_OUT can be calculated from Equation 8:

$$V_{DVR_OUT} = AV_{DD} \left(\frac{R_2}{R_1 + R_2} \right) \left(1 - \frac{\text{RegisterValue} + 1}{256} \left(\frac{R_1}{20R_{SET}} \right) \right) \quad (\text{EQ. 8})$$

With amplifier A2 in the unity-gain configuration (V_{COM_OUT} tied to IN_N as shown in Figure 5), $V_{DVR_OUT} = V_{COM_OUT} = V_{COM}$.

Example

As an example, suppose the AV_{DD} supply is 15V, the desired $V_{COM_MIN} = 6.5V$ and the desired $V_{COM_MAX} = 8.5V$. R_{SET} is arbitrarily chosen to be 7.5k Ω .

First, verify that our chosen R_{SET} meets the minimum requirement described in Equation 5:

$$(7.5\text{k}\Omega) > \left(R_{SET(MIN)} = \left(\frac{\frac{15}{16}}{\left(6.5V - \frac{15}{20} \right)} \right) = 0.163\text{k}\Omega \right) \quad (\text{EQ. 9})$$

Using Equations 6 and 7, calculate the values of R_1 and R_2 :

$$R_1 = 5120 \cdot 7500 \cdot \left(\frac{8.5 - 6.5}{256 \cdot 8.5 - 6.5} \right) = 35.4\text{k}\Omega \quad (\text{EQ. 10})$$

$$R_2 = 5120 \cdot 7500 \cdot \left(\frac{8.5 - 6.5}{255 \cdot 15 + 6.5 - 256 \cdot 8.5} \right) = 46.4\text{k}\Omega \quad (\text{EQ. 11})$$

Table 1 shows the resulting V_{COM} voltage as a function of register value for these conditions.

TABLE 1. EXAMPLE V_{DVR_OUT} vs REGISTER VALUE

REGISTER VALUE	V_{DVR_OUT} (V)
0	8.49
20	8.34
40	8.18
60	8.02
80	7.87
100	7.71
120	7.55
127	7.50
140	7.40
160	7.24
180	7.09
200	6.93
220	6.77
240	6.62
255	6.50

Output Voltage Span Calculation

It is also possible to calculate $V_{COM(MIN)}$ and $V_{COM(MAX)}$ from the existing resistor values.

V_{COM_MIN} occurs when the greatest current, $I_{DVR(MAX)}$, is drawn from the middle node of the R_1/R_2 divider. Substituting RegisterValue = 255 into Equation 8 gives the following:

$$V_{COM(MIN)} = AV_{DD} \left(\frac{R_2}{R_1 + R_2} \right) \left(1 - \left(\frac{R_1}{20R_{SET}} \right) \right) \quad (\text{EQ. 12})$$

Similarly, RegisterValue = 0 for $V_{COM(MAX)}$:

$$V_{COM(MAX)} = AV_{DD} \left(\frac{R_2}{R_1 + R_2} \right) \left(1 - \frac{1}{256} \left(\frac{R_1}{20R_{SET}} \right) \right) \quad (\text{EQ. 13})$$

By finding the difference of Equation 13 and Equation 12, the total span of V_{COM} can be found:

$$V_{COM\ SPAN} = AV_{DD} \left(\frac{R_2}{R_1 + R_2} \right) \left(1 - \frac{1}{256} \right) \left(\frac{R_1}{20R_{SET}} \right) \quad (EQ. 14)$$

Assuming that the $I_{DVR\ OUT(MIN)} = 0$ instead of I_{STEP} , the expression in Equation 14 simplifies to:

$$V_{COM\ SPAN} = \left(\frac{R_1 \cdot R_2}{R_1 + R_2} \right) \left(\frac{AV_{DD}}{20R_{SET}} \right) = \left(\frac{R_1 \cdot R_2}{R_1 + R_2} \right) I_{DVR\ OUT(MAX)} \quad (EQ. 15)$$

DVR_OUT Pin Leakage Current

When the voltage on the DVR_OUT pin is greater than 10V, an additional leakage current flows into the pin in addition to the I_{SET} current. Figure 6 shows the I_{SET} current and the DVR_OUT pin current for DVR_OUT pin voltage up to 19V. In applications where the voltage on the DVR_OUT pin will be greater than 10V, the actual output voltage will be lower than the voltage calculated by Equation 8. The graph in Figure 6 was measured with $R_{SET} = 4.99k\Omega$.

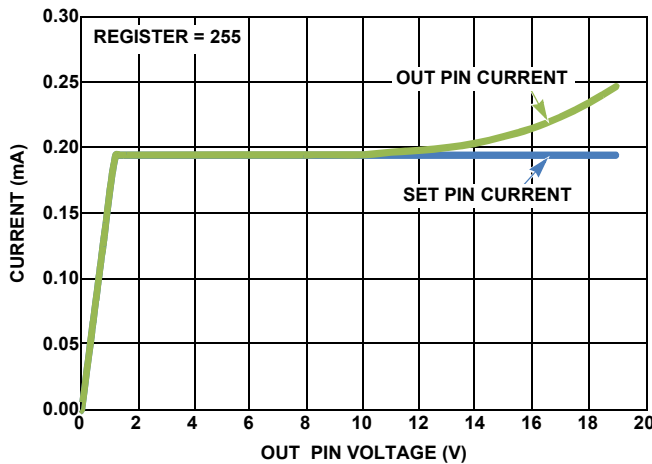

FIGURE 6. DVR_OUT PIN LEAKAGE CURRENT

Power Supply Sequence

The recommended power supply sequencing is shown in Figure 7. When applying power, V_{DD} should be applied before or at the same time as AV_{DD} . The minimum time for t_{VS} is 0µs. When removing power, the sequence of V_{DD} and AV_{DD} is not important.

Do not remove V_{DD} or AV_{DD} within 100ms of the start of the EEPROM programming cycle. Removing power before the EEPROM programming cycle is completed may result in corrupted data in the EEPROM.

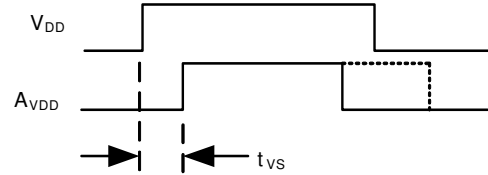

FIGURE 7. POWER SUPPLY SEQUENCE

Operating and Programming Supply Voltage and Current

To program the EEPROM, AV_{DD} must be $\geq 10.8V$. If programming is not required, the ISL24211 will operate over an AV_{DD} range of 4.5V to 19V.

During EEPROM programming, I_{DD} and I_{AVDD} will temporarily be higher than their quiescent currents. Figure 8 shows a typical I_{DD} and I_{AVDD} current profile during EEPROM programming. The current pulses are Erase and Write cycles. The EEPROM programming algorithm is shown in Figure 9. The algorithm attempts up to 4 erase cycles and 4 programming cycles, however typical parts only require 1 cycle of each, sometimes 2 when AV_{DD} is near the minimum 10.8V limit.

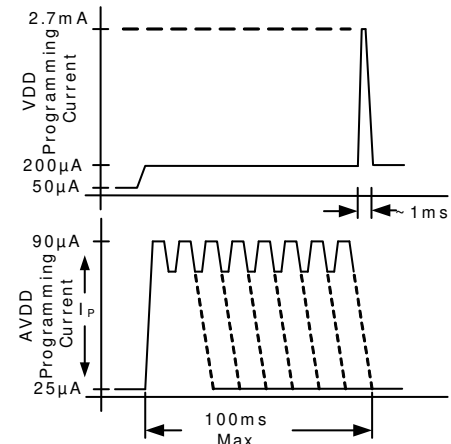

FIGURE 8. I_{DD} AND I_{AVDD} CURRENT PROFILE DURING EEPROM PROGRAMMING

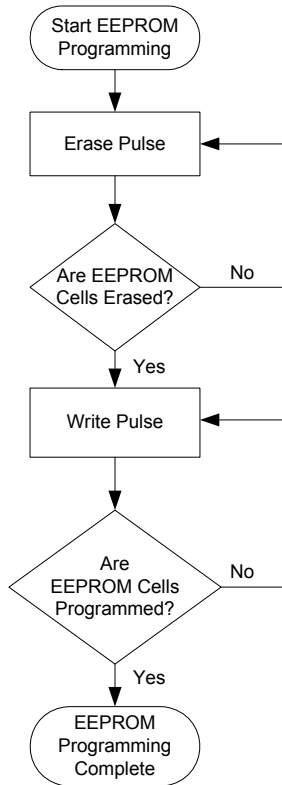

FIGURE 9. EEPROM PROGRAMMING FLOWCHART

ISL24211 Programming

The ISL24211 accepts I²C bus address and data when the \overline{WP} pin is high. The ISL24211 ignores the I²C bus when the \overline{WP} pin is low. Figure 10 shows the serial data format for writing the register and programming the EEPROM. Figure 11 shows the serial data format for reading the DAC register. Table 2 shows the truth table for reading and writing the device.

TABLE 2. ISL24211 READ AND WRITE CONTROL

\overline{WP} PIN	R/ \overline{W}	\overline{P}	FUNCTION
0	1	X	Read Register.
0	0	1	Will acknowledge I ² C transactions. Will not write to register.
0	0	0	Will acknowledge I ² C transactions. Will not write to EEPROM.
1	1	X	Read DAC Register.
1	0	1	Write DAC Register.
1	0	0	Program EEPROM.

Programming the EEPROM memory transfers the current DAC register value to the EEPROM and occurs when the control bits select the programming mode and the AV_{DD} voltage is >10.8V. After the EEPROM programming cycle is started, the \overline{WP} pin can be returned to logic low while the EEPROM write completes, which takes a maximum of 100ms.

The ISL24211 uses a 6-bit I²C address, which is “100111yx” for the first transmitted byte. Bit x is the R/ \overline{W} bit, and Bit y is the LSB (D0) of the DCP register code to be written. The complete read and write protocol is shown in Figures 10 and 11.

I²C Bus Signals

The ISL24211 uses fixed voltages for its I²C thresholds, rather than the percentage of V_{DD} described in the I²C specification (see Table 3). This should not cause a problem in most systems, but the I²C logic levels in a specific design should be checked to ensure they are compatible with the ISL24211.

TABLE 3. ISL24211 I²C BUS LOGIC LEVELS

SYMBOL	ISL24211	I ² C STANDARD
V _{IL_I2C}	0.55V	0.3*V _{DD}
V _{IH_I2C}	1.44V	0.7*V _{DD}

I²C Read and Write Format

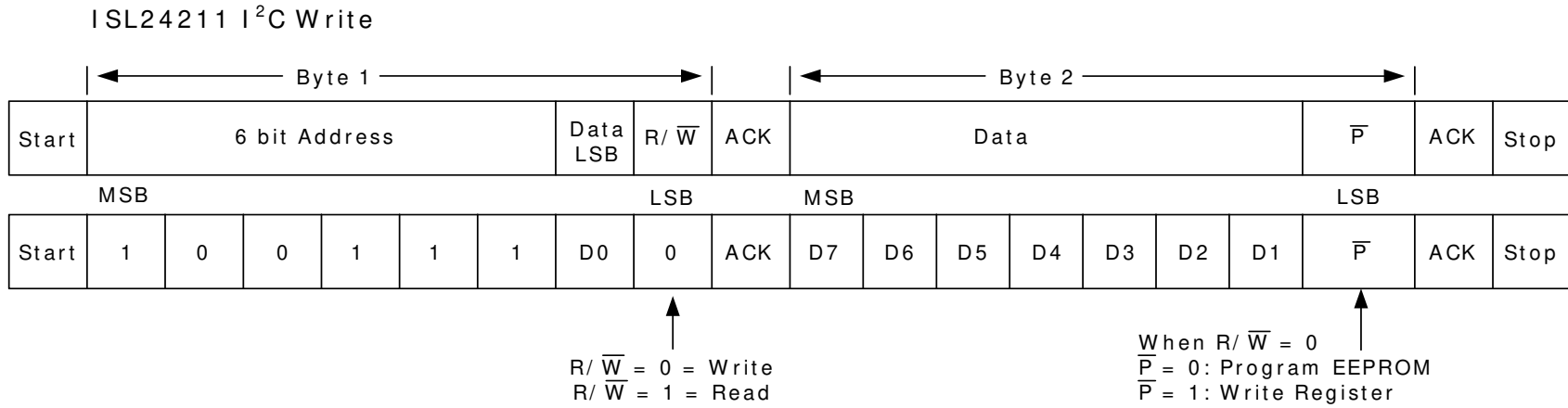

FIGURE 10. I²C WRITE FORMAT

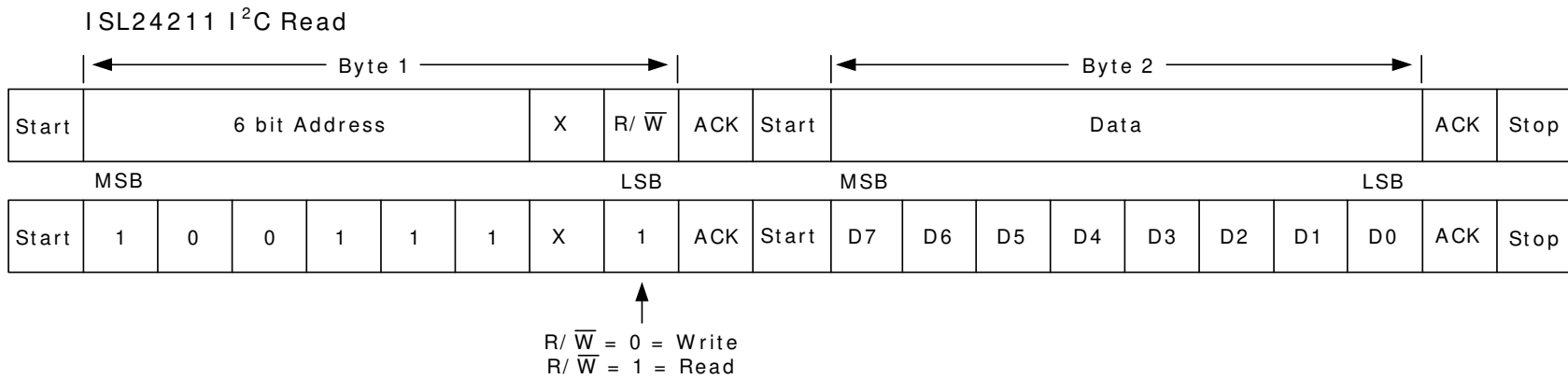

FIGURE 11. I²C READ FORMAT

Revision History

The revision history provided is for informational purposes only and is believed to be accurate, but not warranted. Please go to web to make sure you have the latest revision.

DATE	REVISION	CHANGE
2/23/11	FN7585.0	Initial Release.

Products

Intersil Corporation is a leader in the design and manufacture of high-performance analog semiconductors. The Company's products address some of the industry's fastest growing markets, such as, flat panel displays, cell phones, handheld products, and notebooks. Intersil's product families address power management and analog signal processing functions. Go to www.intersil.com/products for a complete list of Intersil product families.

*For a complete listing of Applications, Related Documentation and Related Parts, please see the respective device information page on intersil.com: [ISL24211](http://www.intersil.com/ISL24211)

To report errors or suggestions for this datasheet, please go to www.intersil.com/askourstaff

FITs are available from our website at <http://rel.intersil.com/reports/search>

© Copyright Intersil Americas LLC 2011. All Rights Reserved.

All trademarks and registered trademarks are the property of their respective owners.

For additional products, see www.intersil.com/en/products.html

Intersil products are manufactured, assembled and tested utilizing ISO9001 quality systems as noted in the quality certifications found at www.intersil.com/en/support/qualandreliability.html

Intersil products are sold by description only. Intersil may modify the circuit design and/or specifications of products at any time without notice, provided that such modification does not, in Intersil's sole judgment, affect the form, fit or function of the product. Accordingly, the reader is cautioned to verify that datasheets are current before placing orders. Information furnished by Intersil is believed to be accurate and reliable. However, no responsibility is assumed by Intersil or its subsidiaries for its use; nor for any infringements of patents or other rights of third parties which may result from its use. No license is granted by implication or otherwise under any patent or patent rights of Intersil or its subsidiaries.

For information regarding Intersil Corporation and its products, see www.intersil.com

Package Outline Drawing

L10.3x3A

10 LEAD THIN DUAL FLAT NO-LEAD PLASTIC PACKAGE

Rev 5, 3/10

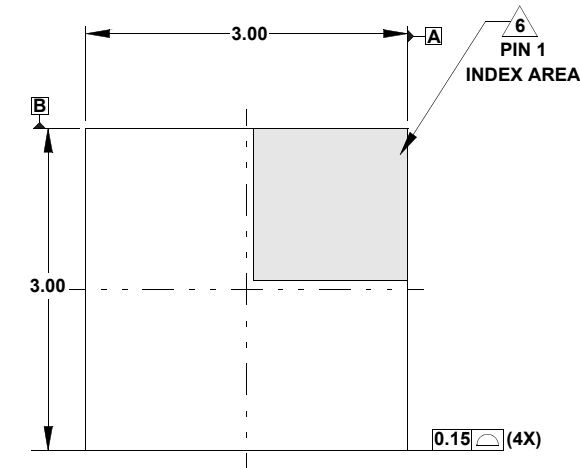

TOP VIEW

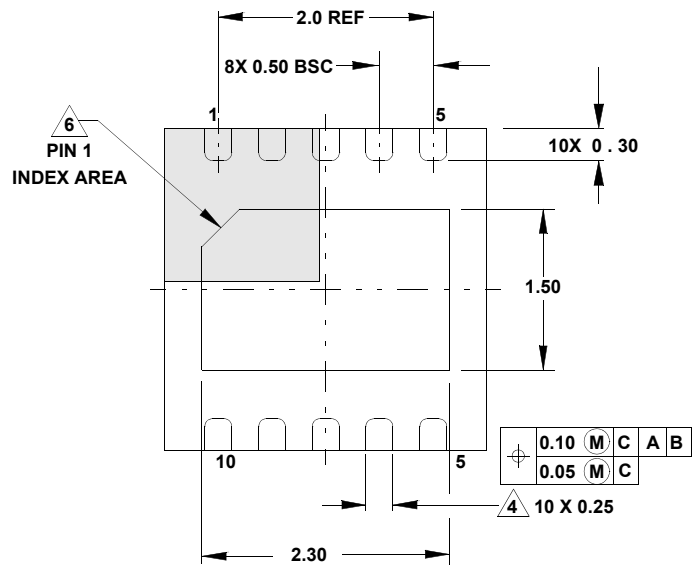

BOTTOM VIEW

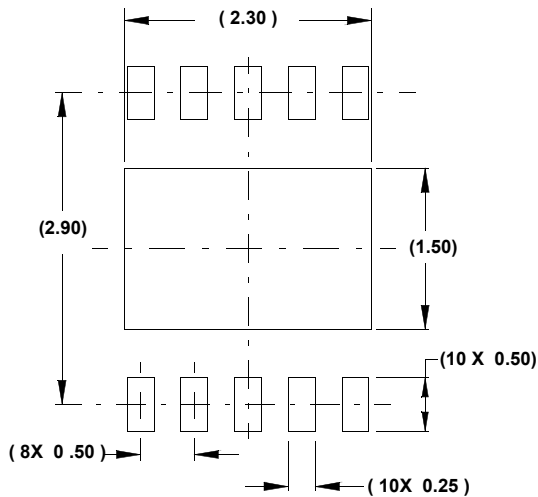

TYPICAL RECOMMENDED LAND PATTERN

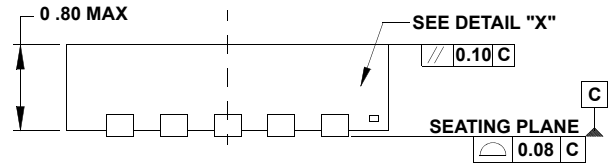

SIDE VIEW

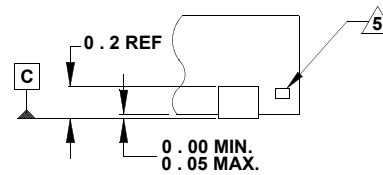

DETAIL "X"

NOTES:

1. Dimensions are in millimeters.
Dimensions in () for Reference Only.
2. Dimensioning and tolerancing conform to ASME Y14.5m-1994.
3. Unless otherwise specified, tolerance : Decimal ± 0.05
Angular $\pm 2.50^\circ$
4. Dimension applies to the metallized terminal and is measured between 0.15mm and 0.30mm from the terminal tip.
5. Tiebar shown (if present) is a non-functional feature.
6. The configuration of the pin #1 identifier is optional, but must be located within the zone indicated. The pin #1 identifier may be either a mold or mark feature.
7. Compliant to JEDEC MO-229-WEED-3 except exposed pad length (2.30mm).