



## N-CHANNEL MOSFET

Qualified per MIL-PRF-19500/555

Qualified Levels:  
JAN, JANTX, and  
JANTXV

### DESCRIPTION

These 2N6788U and 2N6790U devices are military qualified up to a JANTXV level for high-reliability applications. Microsemi also offers numerous other products to meet higher and lower power voltage regulation applications.

**Important:** For the latest information, visit our website <http://www.microsemi.com>.

### FEATURES

- Surface mount equivalent of JEDEC registered 2N6788 and 2N6790 numbers.
- JAN, JANTX, and JANTXV qualifications are available per MIL-PRF-19500/555.
- RoHS compliant by design.

### APPLICATIONS / BENEFITS

- High frequency operation.
- Lightweight, low-profile package.
- ESD rated to class 1A.

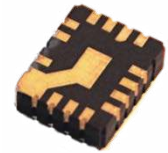
### MAXIMUM RATINGS @ T<sub>C</sub> = +25 °C unless otherwise noted

Parameters / Test Conditions	Symbol	Value	Unit	
Junction & Storage Temperature	T <sub>J</sub> , T <sub>stg</sub>	-55 to +150	°C	
Thermal Resistance Junction-to-Case (see <a href="#">Figure 1</a> )	R <sub>θJC</sub>	8.93	°C/W	
Total Power Dissipation <sup>(1)</sup>	P <sub>T</sub>	0.8	W	
Drain to Gate Voltage	V <sub>DG</sub>	2N6788U 2N6790U	100 200	V
Drain – Source Voltage		V <sub>DS</sub>	2N6788U 2N6790U	100 200
Gate – Source Voltage	V <sub>GS</sub>		± 20	V
Drain Current, dc @ T <sub>C</sub> = +25 °C <sup>(2)</sup> (see <a href="#">Figure ?</a> )	I <sub>D1</sub>	2N6788U 2N6790U	4.5 2.8	A
Drain Current, dc @ T <sub>C</sub> = +100 °C		I <sub>D2</sub>	2N6788U 2N6790U	2.8 1.8
Off-State Current <sup>(3)</sup>	I <sub>DM</sub>		2N6788U 2N6790U	18 11
Source Current		I <sub>S</sub>	2N6788U 2N6790U	4.5 2.8

- Notes:**
1. Derated linearly by 0.11 W/°C for T<sub>C</sub> > +25 °C.
  2. The following formula derives the maximum theoretical I<sub>D</sub> limit. I<sub>D</sub> is also limited by package and internal wires and may be limited due to pin diameter.

$$I_D = \sqrt{\frac{T_J(\text{max}) - T_C}{R_{\theta JC} \times R_{DS(\text{on})} @ T_J(\text{max})}}$$

3. I<sub>DM</sub> = 4 × I<sub>D1</sub>; I<sub>D1</sub> as calculated in note 2.



### U-18 LCC Package

Also available in:

**TO-205AF Package**  
(leaded)

 [2N6788 & 2N6790](#)

#### **MSC – Lawrence**

6 Lake Street,  
Lawrence, MA 01841  
Tel: 1-800-446-1158 or  
(978) 620-2600  
Fax: (978) 689-0803

#### **MSC – Ireland**

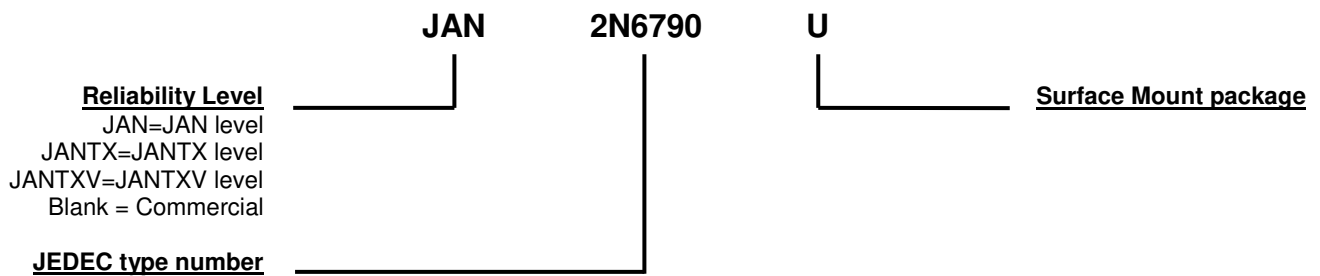
Gort Road Business Park,  
Ennis, Co. Clare, Ireland  
Tel: +353 (0) 65 6840044  
Fax: +353 (0) 65 6822298

**Website:**

[www.microsemi.com](http://www.microsemi.com)

**MECHANICAL and PACKAGING**

- CASE: Ceramic LCC-18 with kovar gold plated lid.
- TERMINALS: Gold plating over nickel.
- MARKING: Manufacturer's ID, part number, date code, ESD symbol at pin 1 location.
- TAPE & REEL option: Standard per EIA-481-D. Consult factory for quantities.
- See [Package Dimensions](#) on last page.

**PART NOMENCLATURE**

**SYMBOLS & DEFINITIONS**

Symbol	Definition
$I_D$	Drain current.
$I_F$	Forward current.
$T_C$	Case temperature.
$V_{DD}$	Drain supply voltage.
$V_{DS}$	Drain to source voltage.
$V_{GS}$	Gate to source voltage.

**ELECTRICAL CHARACTERISTICS @  $T_A = +25\text{ }^\circ\text{C}$ , unless otherwise noted**

Parameters / Test Conditions	Symbol	Min.	Max.	Unit
<b>OFF CHARACTERISTICS</b>				
Drain-Source Breakdown Voltage $V_{GS} = 0\text{ V}, I_D = 1\text{ mA}$	2N6788U 2N6790U $V_{(BR)DSS}$	100 200		V
Gate-Source Voltage (Threshold) $V_{DS} \geq V_{GS}, I_D = 0.25\text{ mA}$ $V_{DS} \geq V_{GS}, I_D = 0.25\text{ mA}, T_j = +125\text{ }^\circ\text{C}$ $V_{DS} \geq V_{GS}, I_D = 0.25\text{ mA}, T_j = -55\text{ }^\circ\text{C}$	$V_{GS(th)1}$ $V_{GS(th)2}$ $V_{GS(th)3}$	2.0 1.0	4.0 5.0	V
Gate Current $V_{GS} = \pm 20\text{ V}, V_{DS} = 0\text{ V}$ $V_{GS} = \pm 20\text{ V}, V_{DS} = 0\text{ V}, T_j = +125\text{ }^\circ\text{C}$	$I_{GSS1}$ $I_{GSS2}$		$\pm 100$ $\pm 200$	nA

Parameters / Test Conditions	Symbol	Min.	Max.	Unit
<b>ON CHARACTERISTICS</b>				
Drain Current $V_{GS} = 0\text{ V}, V_{DS} = 80\text{ V}$ $V_{GS} = 0\text{ V}, V_{DS} = 160\text{ V}$	2N6788U 2N6790U $I_{DSS1}$		25	$\mu\text{A}$
Drain Current $V_{GS} = 0\text{ V}, V_{DS} = 80\text{ V}, T_j = +125\text{ }^\circ\text{C}$ $V_{GS} = 0\text{ V}, V_{DS} = 160\text{ V}, T_j = +125\text{ }^\circ\text{C}$	2N6788U 2N6790U $I_{DSS2}$		0.25	mA
Static Drain-Source On-State Resistance $V_{GS} = 10\text{ V}, I_D = 3.5\text{ A pulsed}$ $V_{GS} = 10\text{ V}, I_D = 2.25\text{ A pulsed}$	2N6788U 2N6790U $r_{DS(on)1}$		0.30 0.80	$\Omega$
Static Drain-Source On-State Resistance $V_{GS} = 10\text{ V}, I_D = 6.0\text{ A pulsed}$ $V_{GS} = 10\text{ V}, I_D = 3.5\text{ A pulsed}$	2N6788U 2N6790U $r_{DS(on)2}$		0.35 0.85	$\Omega$
Static Drain-Source On-State Resistance $T_j = +125\text{ }^\circ\text{C}$ : $V_{GS} = 10\text{ V}, I_D = 3.5\text{ A pulsed}$ $V_{GS} = 10\text{ V}, I_D = 2.25\text{ A pulsed}$	2N6788U 2N6790U $r_{DS(on)3}$		0.54 1.50	$\Omega$
Diode Forward Voltage $V_{GS} = 0\text{ V}, I_D = 6.0\text{ A pulsed}$ $V_{GS} = 0\text{ V}, I_D = 3.5\text{ A pulsed}$	2N6788U 2N6790U $V_{SD}$		1.8 1.5	V

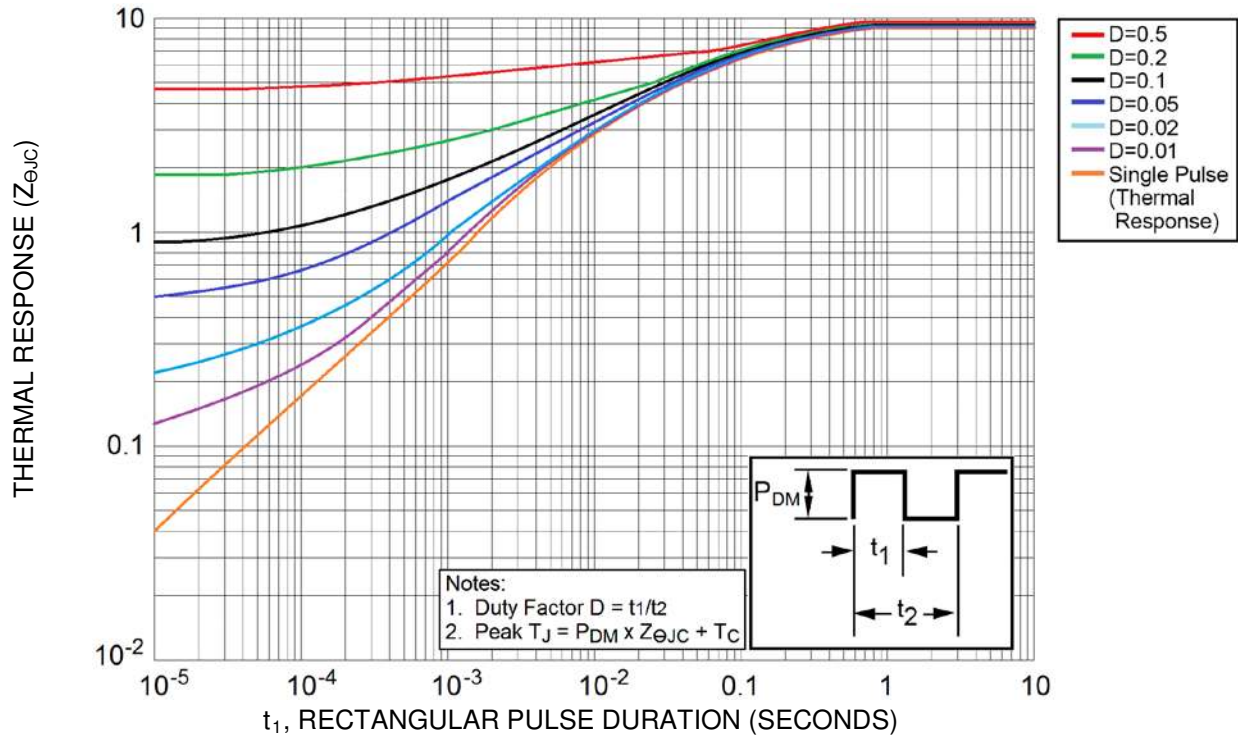
**ELECTRICAL CHARACTERISTICS @  $T_A = +25\text{ }^\circ\text{C}$ , unless otherwise noted (continued)**
**DYNAMIC CHARACTERISTICS**

Parameters / Test Conditions	Symbol	Min.	Max.	Unit
Gate Charge:				
On-State Gate Charge $V_{GS} = 10\text{ V}, I_D = 6.0\text{ A}, V_{DS} = 50\text{ V}$ $V_{GS} = 10\text{ V}, I_D = 3.5\text{ A}, V_{DS} = 100\text{ V}$	$Q_{g(on)}$		18.0 14.3	nC
Gate to Source Charge $V_{GS} = 10\text{ V}, I_D = 6.0\text{ A}, V_{DS} = 50\text{ V}$ $V_{GS} = 10\text{ V}, I_D = 3.5\text{ A}, V_{DS} = 100\text{ V}$	$Q_{gs}$		4.0 3.0	nC
Gate to Drain Charge $V_{GS} = 10\text{ V}, I_D = 6.0\text{ A}, V_{DS} = 50\text{ V}$ $V_{GS} = 10\text{ V}, I_D = 3.5\text{ A}, V_{DS} = 100\text{ V}$	$Q_{gd}$		9.0 9.0	nC

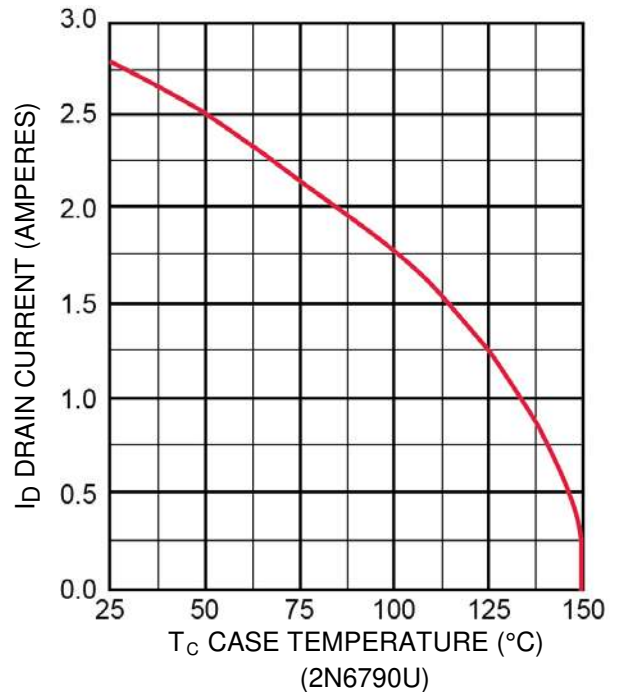
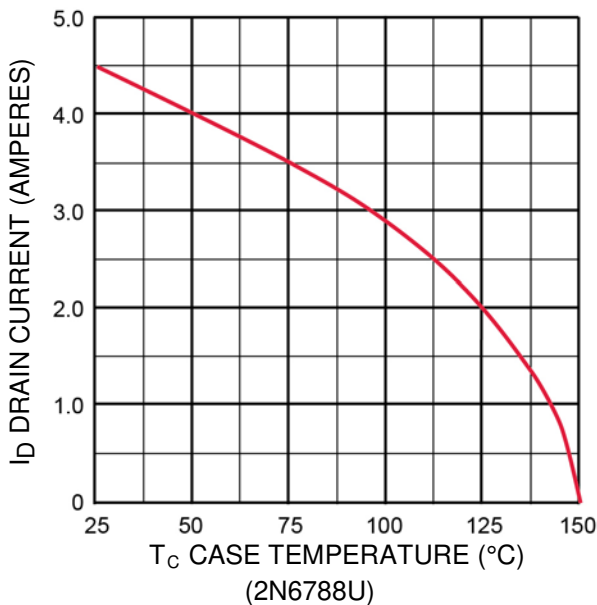
**SWITCHING CHARACTERISTICS**

Parameters / Test Conditions	Symbol	Min.	Max.	Unit
Turn-on delay time $I_D = 6.0\text{ A}, V_{GS} = 10\text{ V}, R_G = 7.5\text{ }\Omega, V_{DD} = 35\text{ V}$ $I_D = 3.5\text{ A}, V_{GS} = 10\text{ V}, R_G = 7.5\text{ }\Omega, V_{DD} = 74\text{ V}$	$t_{d(on)}$		40	ns
Rinse time $I_D = 6.0\text{ A}, V_{GS} = 10\text{ V}, R_G = 7.5\text{ }\Omega, V_{DD} = 35\text{ V}$ $I_D = 3.5\text{ A}, V_{GS} = 10\text{ V}, R_G = 7.5\text{ }\Omega, V_{DD} = 74\text{ V}$	$t_r$		70 50	ns
Turn-off delay time $I_D = 6.0\text{ A}, V_{GS} = 10\text{ V}, R_G = 7.5\text{ }\Omega, V_{DD} = 35\text{ V}$ $I_D = 3.5\text{ A}, V_{GS} = 10\text{ V}, R_G = 7.5\text{ }\Omega, V_{DD} = 74\text{ V}$	$t_{d(off)}$		40 50	ns
Fall time $I_D = 6.0\text{ A}, V_{GS} = 10\text{ V}, R_G = 7.5\text{ }\Omega, V_{DD} = 35\text{ V}$ $I_D = 3.5\text{ A}, V_{GS} = 10\text{ V}, R_G = 7.5\text{ }\Omega, V_{DD} = 74\text{ V}$	$t_f$		70 50	ns
Diode Reverse Recovery Time $di/dt = 100\text{ A}/\mu\text{s}, V_{DD} \leq 50\text{ V}, I_F = 6.0\text{ A}$ $di/dt = 100\text{ A}/\mu\text{s}, V_{DD} \leq 50\text{ V}, I_F = 3.5\text{ A}$	$t_{rr}$		240 400	ns

GRAPHS

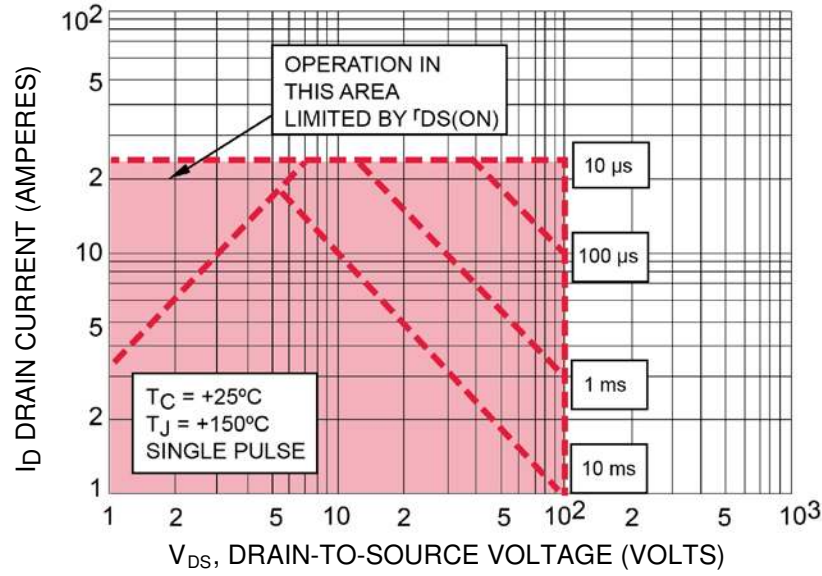


**Figure 1**  
 Thermal Impedance Curves

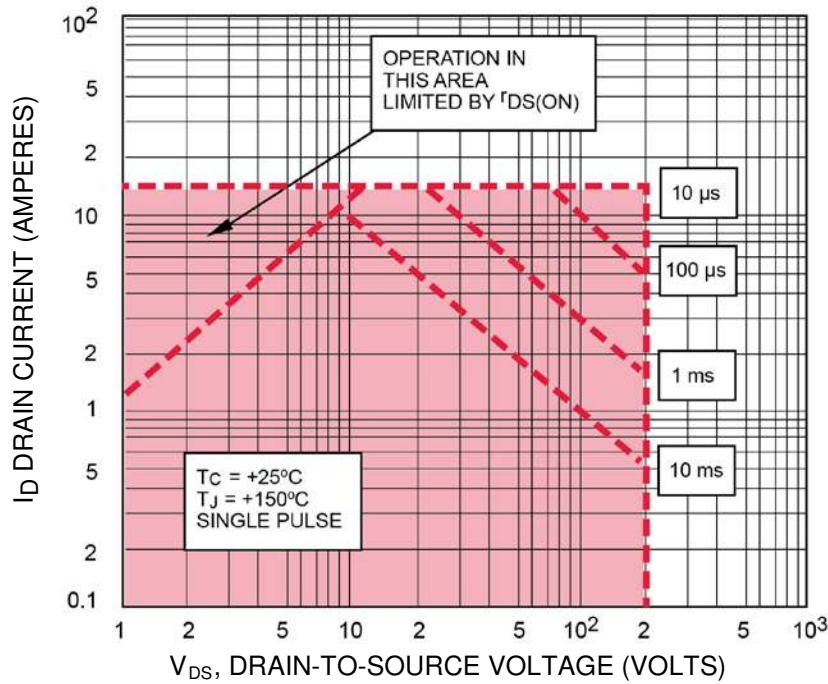


**Figure 2**  
 Maximum Drain Current vs. Case Temperature Graph

GRAPHS (continued)

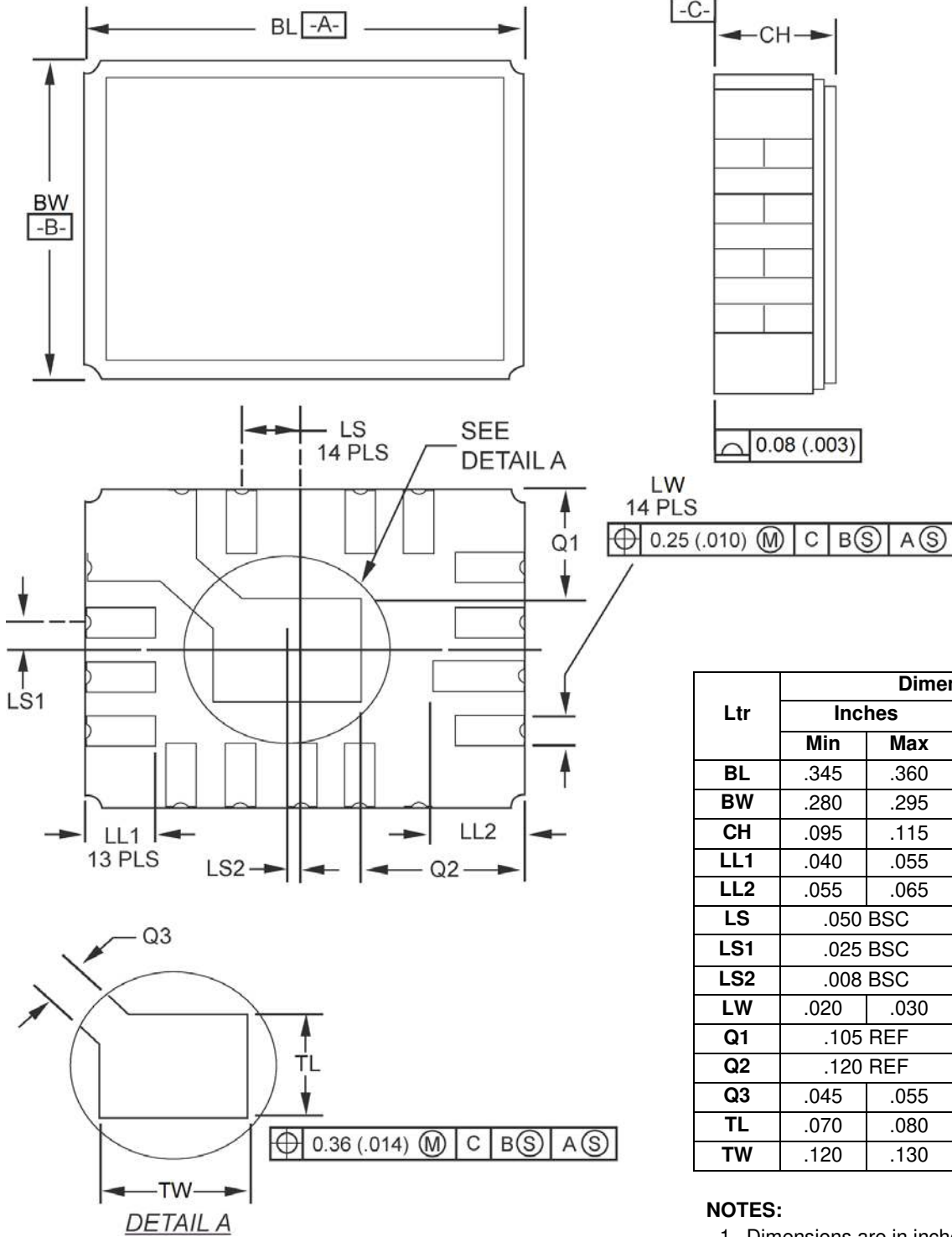


Maximum Safe Operating Area (2N6788U)



Maximum Safe Operating Area (2N6790U)

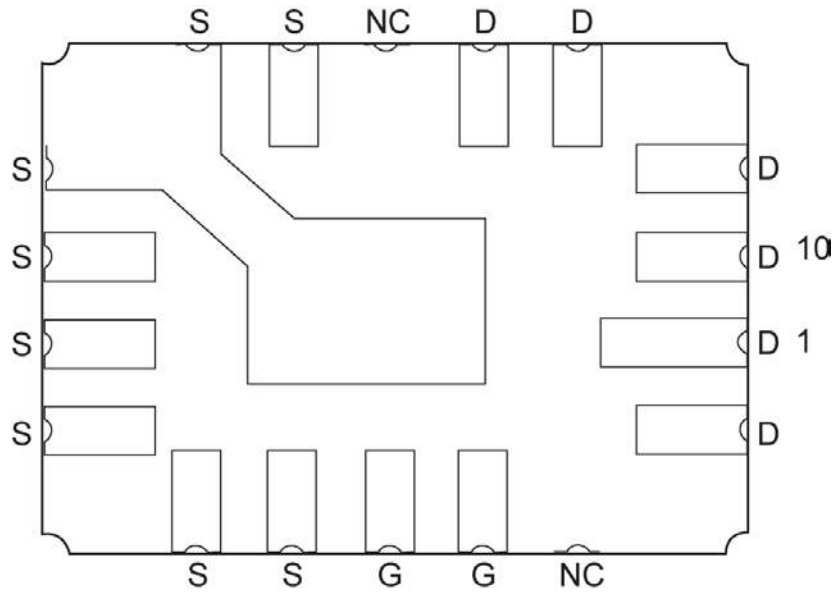
PACKAGE DIMENSIONS



Ltr	Dimensions			
	Inches		Millimeters	
	Min	Max	Min	Max
BL	.345	.360	8.77	9.14
BW	.280	.295	7.12	7.49
CH	.095	.115	2.42	2.92
LL1	.040	.055	1.02	1.39
LL2	.055	.065	1.40	1.65
LS	.050 BSC		1.27 BSC	
LS1	.025 BSC		0.635 BSC	
LS2	.008 BSC		0.203 BSC	
LW	.020	.030	0.51	0.76
Q1	.105 REF		2.67 REF	
Q2	.120 REF		3.05 REF	
Q3	.045	.055	1.14	1.40
TL	.070	.080	1.78	2.03
TW	.120	.130	3.05	3.30

- NOTES:**
1. Dimensions are in inches.
  2. Millimeters are given for general information only.
  3. In accordance with ASME Y14.5M, diameters are equivalent to  $\Phi$ x symbology.

**PAD LAYOUT**



**PAD ASSIGNMENTS**