

LOC	DIST	REVISIONS					
		P.	LTN	DESCRIPTION	DATE	DWN	APVD
ES	00	2		REV PER ECR-07-015159	03JUL2007	CZ	SY
		3		ADDED NEW DASH NUMBER	26JUL2007	DZ	SY

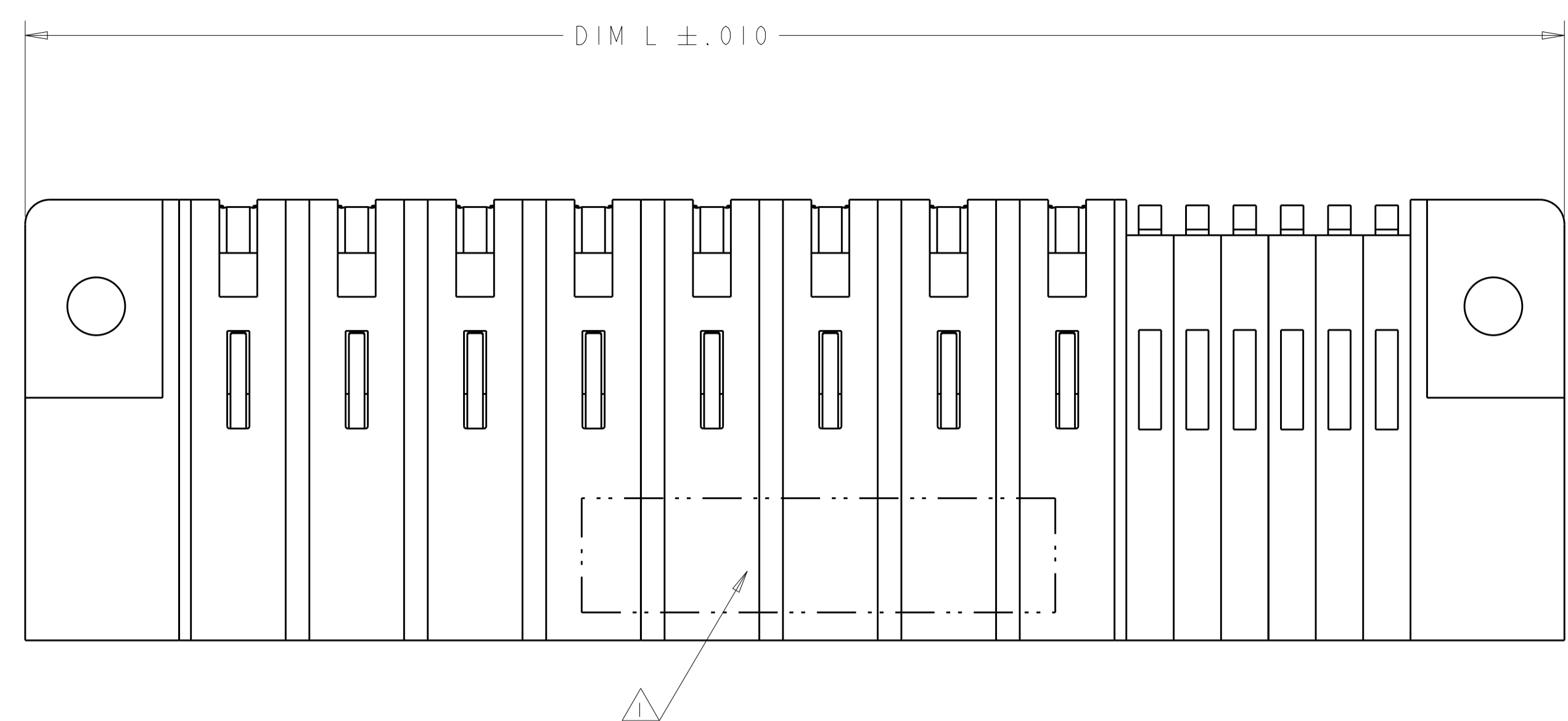

- 1 PART NUMBER, AND DATE CODE MARKED IN AREA SHOWN. MARKING ON BOTH SIDES PERMITTED FOR PARTS UNDER 2.00 LONG.
- 2 MATERIAL:
HOUSING - GLASS FILLED HIGH TEMP THERMO PLASTIC, UL94 V-0
SIGNAL CONTACT - COPPER ALLOY
POWER CONTACT - HIGH CONDUCTIVITY COPPER ALLOY
- 3 CONTACT PLATING: NOBLE METAL PLATING ON CONTACT FUNCTIONAL AREA OF POWER AND SIGNAL CONTACTS
- 4 MECHANICAL CONNECTOR KEEP OUT ZONE.
- 5 DATUM AND BASIC DIMENSIONS ESTABLISHED BY CUSTOMER.
- 6 PCB - ALL HOLE DIAMETERS ARE FINISHED HOLE SIZES.
- 7 PCB - .0453±.0010 DRILLED HOLES PLATED WITH .0003 MIN Sn OVER .001 TO .003 Cu PLATING TO ACHIEVE A .040 HOLE.
- 8 NOT RELEASED FOR PRODUCTION.

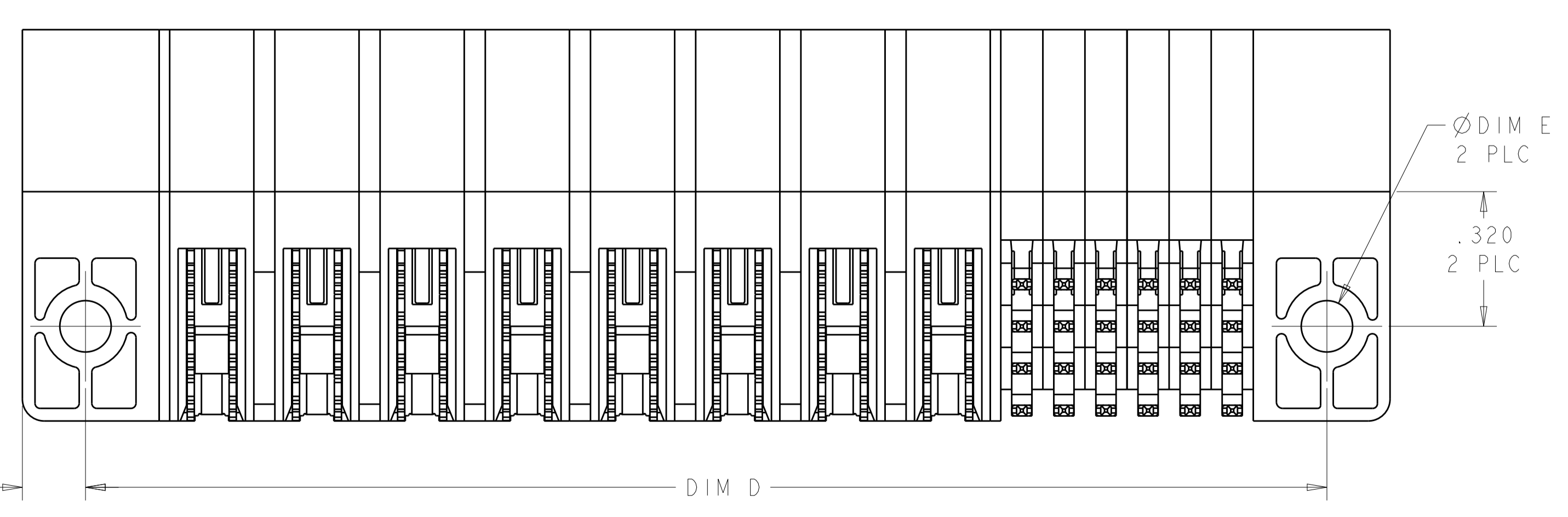
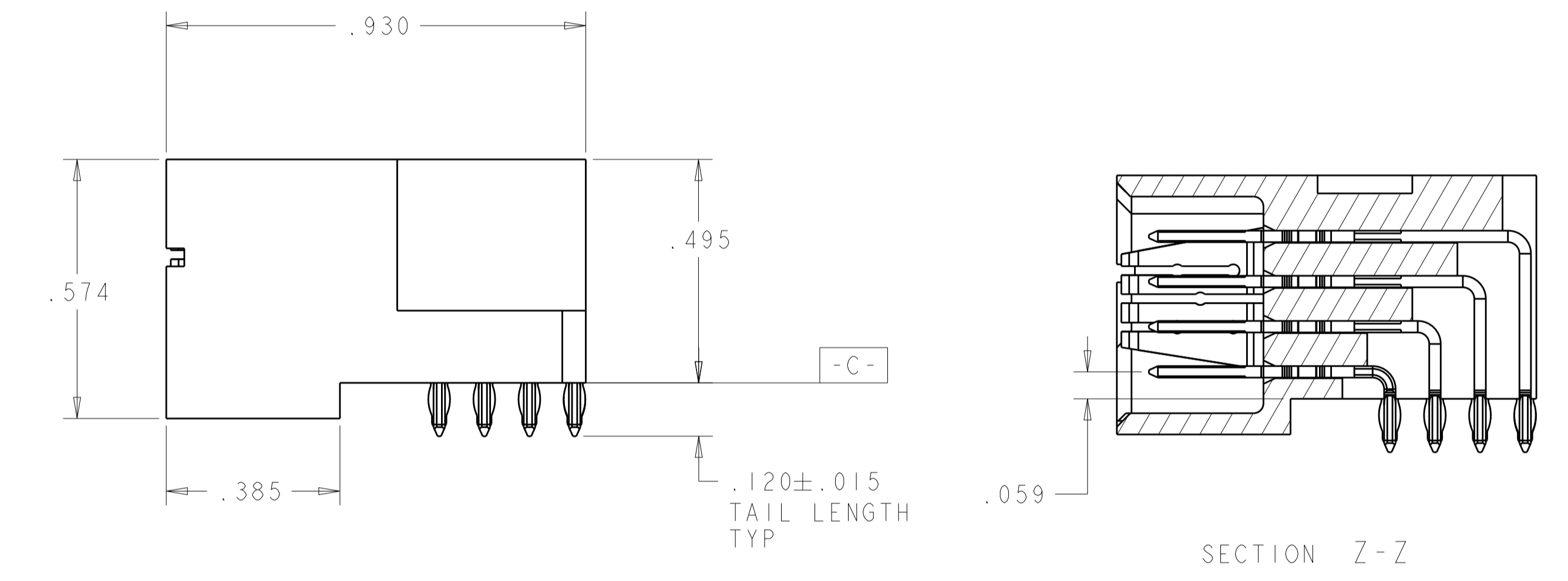
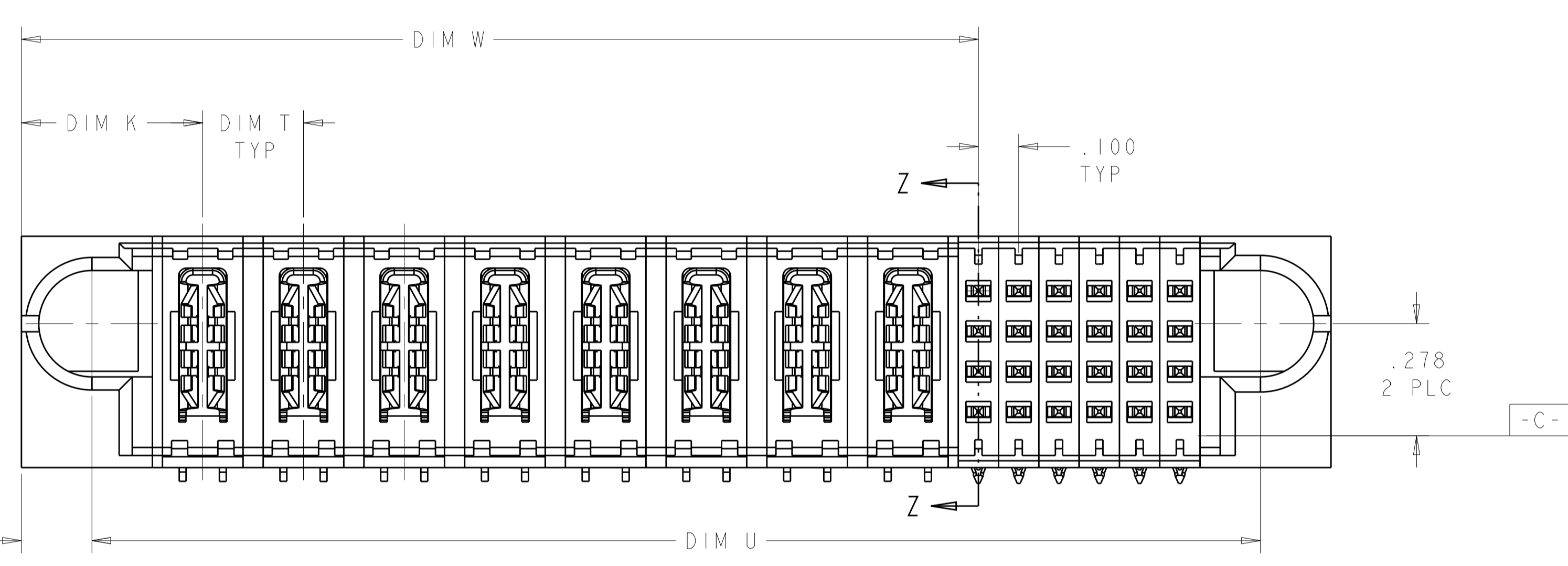

DIM E	DIM U	DIM T	DIM W	DIM D	DIM L	DIM K	DESCRIPTION	PART NUMBER
.150	1.400	.250	.875	1.450	1.750	.450	2P + 24S	6450632-2
.122	2.900	.250	2.375	2.950	3.250	.450	8P + 24S	6450632-1

DIMENSIONS: INCHES		TOLERANCES UNLESS OTHERWISE SPECIFIED:		DWN: C. ZHOU 28JUN2007		CHK: S. ZHAO 28JUN2007		APVD: S. YAO		NAME: S. YAO		Tyco Electronics Corporation Shanghai, P.R.China. 200233	
0 PLC ±.1		1 PLC ±.01		2 PLC ±.01		3 PLC ±.005		4 PLC ±.0020		PRODUCT SPEC: 108-1973		APPLICATION SPEC: 114-13038	
MATERIAL: 2		FINISH: 3		WEIGHT: -		SCALE: 4:1		SHEET: 1 OF 2		REV: 3		RESTRICTED TO: -	

