

ZC1003HF

SMD Z axis for NFC applications

10x10x3.2mm

NFC ANTENNAS



FEATURES

This component is a Z-axis SMD ferrite antenna suitable for signal reception/transmission at 13.56MHz. **ZC1003HF series is a highly sensitive and compact solution** (10x10x3.1mm) specially designed for those NFC applications where size of components is critical. This innovative antenna requires less board space compared with antennas designed for a PCB and offers larger reading distances. Furthermore, this Z-axis coil's design offers an outstanding electrical performance and mechanical robustness, providing an excellent reliability.

ZC1003HF series is offered with 2,5µH-4,5µH (@13.56MHz) inductance value and can be custom according to customer's specifications.



01 CHARACTERISTICS

- › Very good electrical and mechanical performance.
- › High performance NiZn ferrite core material (>10⁶ Ohm·m)
- › High stability in temperature: (-40°C to +100°C).
- › High sensitivity values achieved with very good thermal performance.
- › RoHS compliant

02 APPLICATIONS

- › This component is functional to 13,56 MHz (NFC applications)
- › Can be used in RFID applications with ISO15693 (vicinity: I-CODE), ISO 14443A&B (proximity: MIFARE) interface, ISO18092, and Felica.

03 SPECIFICATIONS

DIMENSIONS (mm)

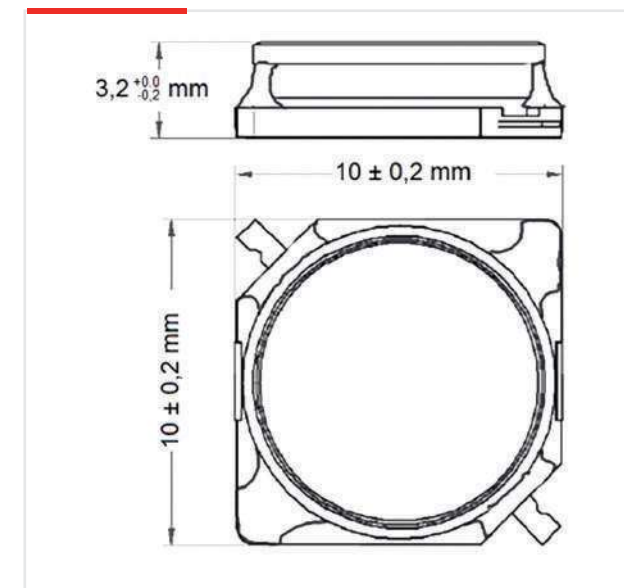

RECOMMENDED PAD-LAYOUT

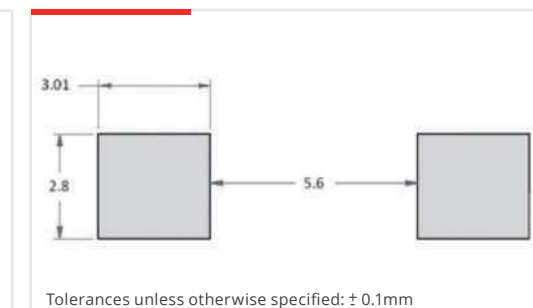

ELECTRICAL SPECIFICATIONS | 13,56 MHz

	L @13,56 MHz (µH)	Q min. @13,56MHz	SRF(MHz) Min	DCR.(Ohm)
ZC1003HF-00022K	2.2 ± 10%	80	25	0.130 ± 10%
ZC1003HF-00045K	4.5 ± 10%	80	25	0.380 ± 10%

The specification chart is a reference guide for the most common required values at working frequencies of 13,56MHz. Any other inductance value at HF or tighter tolerances can be provided. Please contact our sales department for any inquiry.