

PRODUCT NUMBER  
SEE TABLE, SHEET 5

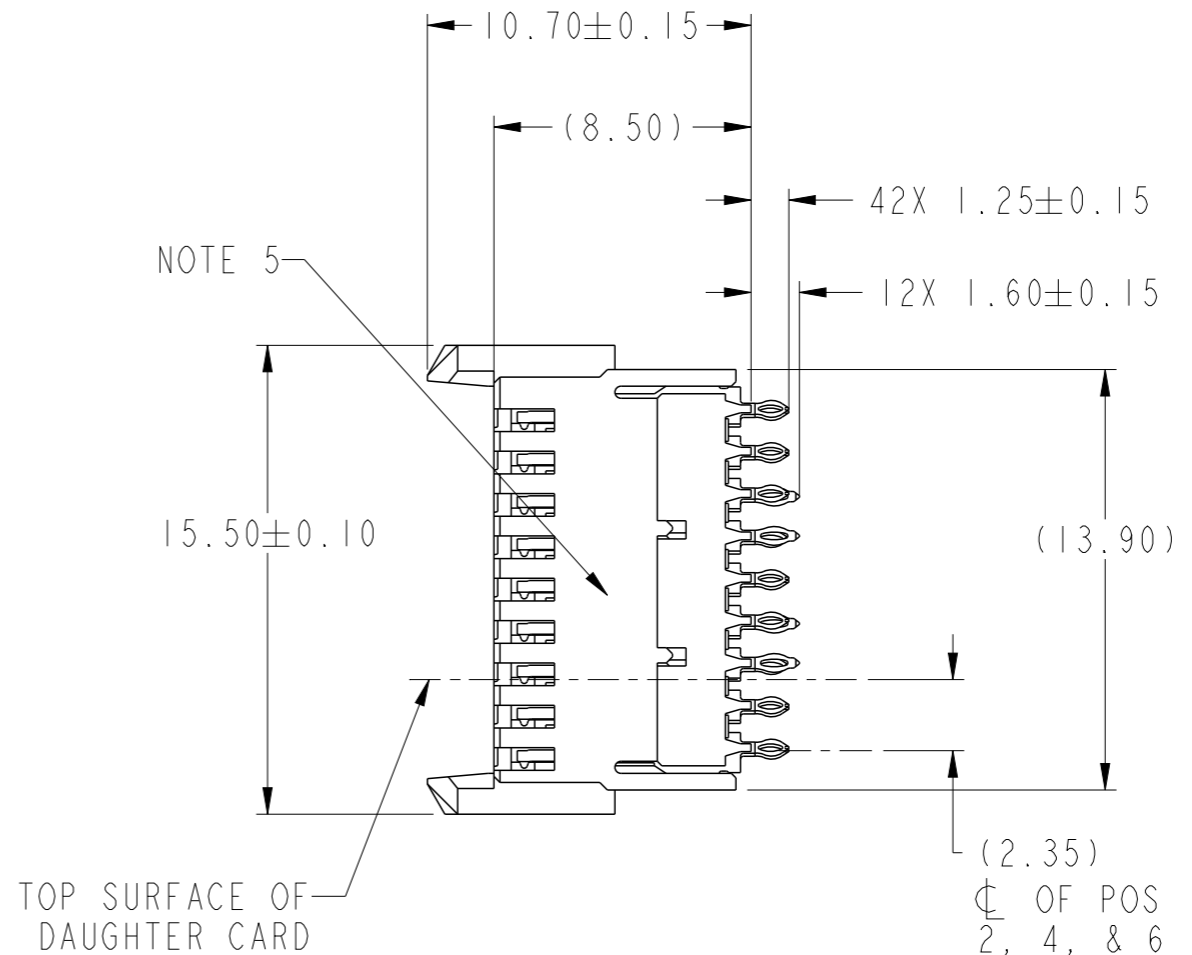
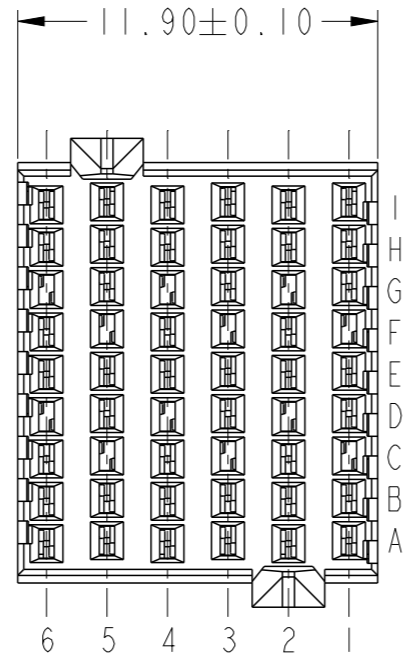

Amphenol  
FCi

© 2016 AFCI

spec ref		dr	Manoharan Srin	2012/05/02	projection	MM	size	A3	scale	4:1
tolerance std		eng	Barry Liang	2019/04/18			ecn no		ELX-DG-33220-1	
ASME Y14.5		chr	-	-			rel level		Released	
TOLERANCES UNLESS OTHERWISE SPECIFIED		appr	Heaven Cen	2019/05/16	product family		AirMax VS			
surface	linear	0.X		±-	<b>Amphenol FCi</b>	Airmax VS VERT RECEPTACLE		dwg no 10120757	rev	
		0.XX		±-		SMALL PRESS-FIT, 54 POS, 12MM			C	
ASME Y14.5		angular	0°		cat. no.	-		Product - Customer Drw		sheet 1 of 3

ADJACENT HEADER WIDTHS	DIM A	DIM B
12MM/12MM	2.00	12.00
12MM/14MM	3.00	13.00
14MM/14MM	4.00	14.00

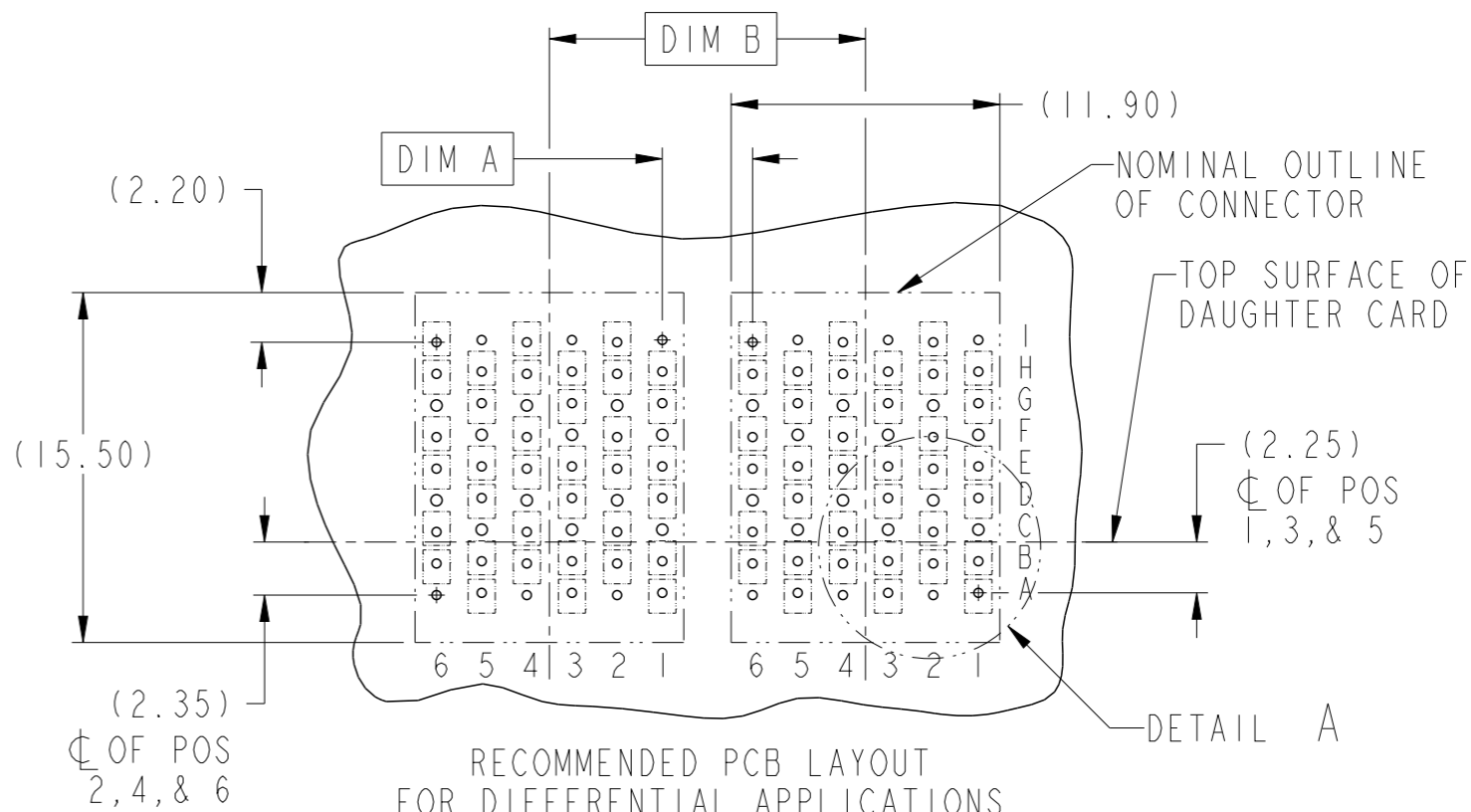
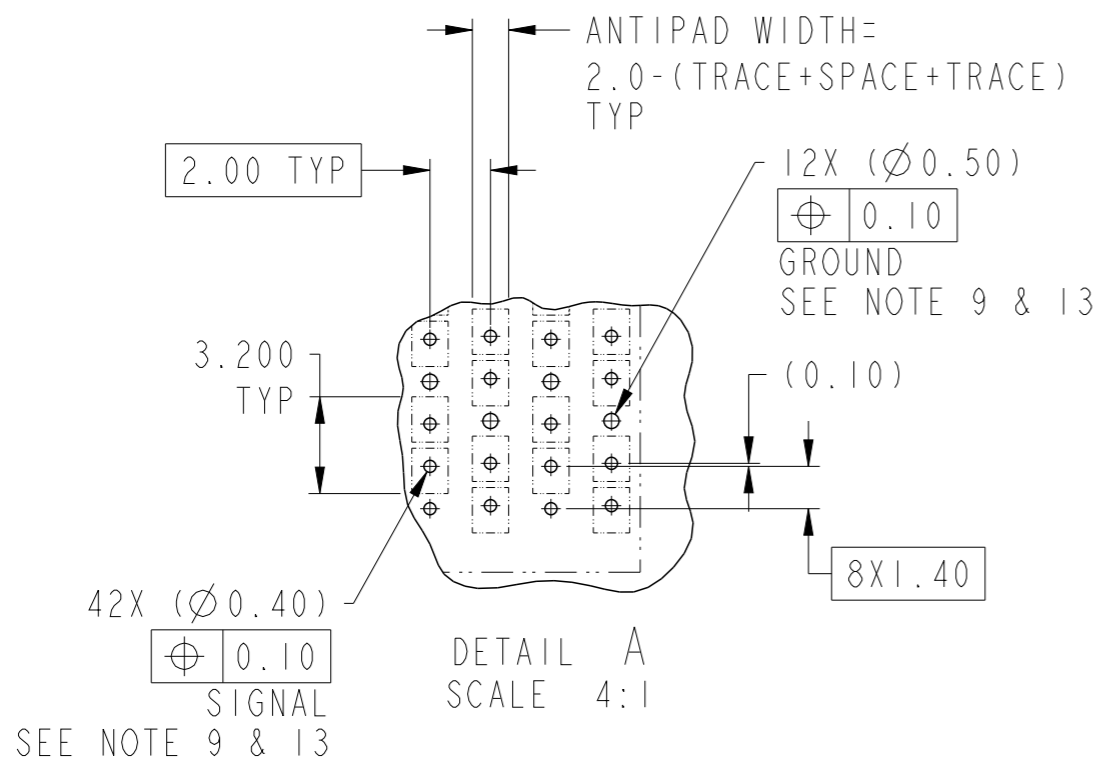



RECOMMENDED PCB LAYOUT  
FOR DIFFERENTIAL APPLICATIONS  
COMPONENT SIDE  
(TWO ADJACENT FOOTPRINTS SHOWN)  
NOTES 6 & 7

spec ref	dr	Manoharan Srin	2012/05/02	projection	MM	size	A3	scale	3:1
tolerance std	eng	Barry Liang	2019/04/18			ecn no	ELX-DG-33220-1	rel level	Released
ASME Y14.5	chr	-	-						
	appr	Heaven Cen	2019/05/16	product family	AirMax VS				
surface	linear	0.X	±-	<b>Amphenol FCI</b> Airmax VS VERT RECEPTACLE SMALL PRESS-FIT, 54 POS, 12MM	cat. no. - Product - Customer Drw	dwg no 10120757	rev C	sheet 2 of 3	ASME Y14.5 angular 0° ±°
		0.XX	±-						
		0.XXX	±-						

PART NUMBER	PRESS-FIT TAIL PLATING TYPE
10120757-101	TIN/LEAD ALLOY OVER NICKEL
10120757-101LF	TIN OVER NICKEL (LEAD FREE)

NOTES:

1. CONNECTOR MATERIALS:  
HOUSING & RETAINER: HIGH TEMP THERMOPLASTIC, NATURAL, UL94V-0  
IMLA PLASTIC: HIGH TEMP THERMOPLASTIC, BLACK, UL94V-0  
CONTACT: COPPER ALLOY
2. CONTACT PLATING:  
SEPARABLE INTERFACE: PERFORMANCE-BASED PLATING, QUALIFIED TO MEET THE REQUIREMENTS OF FCI PRODUCT SPECIFICATION GS-12-239, INCLUDING TELCORDIA GR-1217-CORE (November 1995) CENTRAL OFFICE TEST SEQUENCE.  
  
PRESS-FIT TAILS: SEE TABLE
3. PRODUCT SPECIFICATION: GS-12-239
4. APPLICATION SPECIFICATION: GS-20-035
5. PRODUCT MARKING, (PART NUMBER & LOT CODE), ON THIS SURFACE
6. REFER TO CUSTOMER DRAWING 10035911 FOR INFORMATION REGARDING PCB LAYOUT OF POWER AND GUIDE MODULES RELATIVE TO SIGNAL MODULES
7. POSITIONS F OF ODD NUMBERED COLUMNS AND POSITIONS G OF EVEN NUMBERED COLUMNS CORRESPOND TO EARLY MATE HEADER PINS
8. THERE IS NO GROUND BUSSING WITHIN THE CONNECTOR SYSTEM
9. REFER TO CUSTOMER DRAWING 10104444 FOR INFORMATION ON PCB HOLE DIAMETERS AND PLATING OPTIONS.
10. THIS PRODUCT MEETS EUROPEAN UNION DIRECTIVES AND OTHER COUNTRY REGULATIONS AS DESCRIBED IN GS-22-008.
11. THE HOUSING WILL WITHSTAND EXPOSURE TO 260°C PEAK TEMPERATURE FOR 40 SECONDS IN A CONVECTION, INFRA-RED OR VAPOR PHASE REFLOW OVEN.
12. PACKAGING MEETS GS-14-920 LEAD FREE LABELING SPECIFICATION.
13.  GROUND VIAS IN POSITON C & F FOR ODD COLUMNS AND POSITIONS D & G FOR EVEN COLUMNS REQUIRE (Ø0.50) FINISHED HOLES. ALL OTHER VIAS REQUIRE (Ø0.40) FINISHED HOLES.
14.  SYMBOL WILL BE NEXT TO ANY DIMENSION, VIEW, OR NOTE THAT HAS BEEN MODIFIED WITH THE CURRENT DRAWING REVISION.

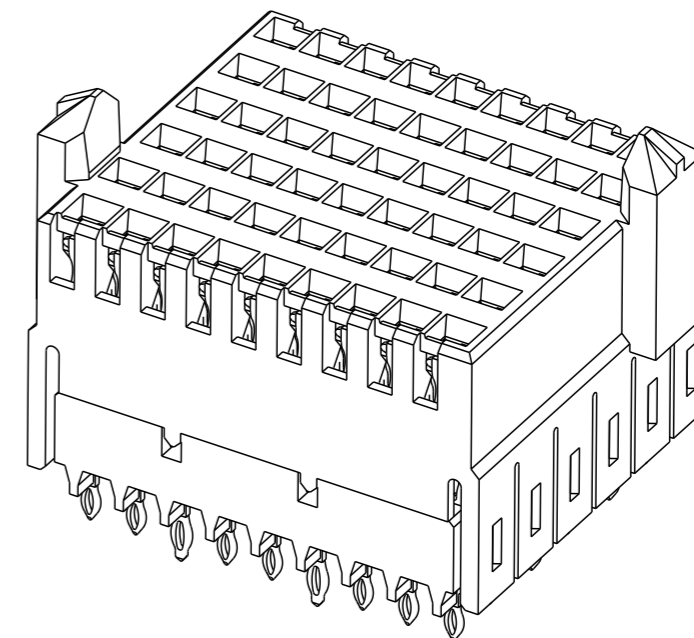

Amphenol FCI

© 2016 AFCI

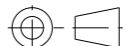
spec ref		dr	Manoharan Srin	2012/05/02	projection	MM	size	A3	scale	3:1						
tolerance std		eng	Barry Liang	2019/04/18		← →	ecn no	ELX-DG-33220-1								
ASME Y14.5		chr	-	-				rel level	Released							
TOLERANCES UNLESS OTHERWISE SPECIFIED		appr	Heaven Cen	2019/05/16	product family		AirMax VS									
surface	-	Amphenol FCI			Airmax VS VERT RECEPTACLE			dwg no		10120757						
linear	0.X											±-	rev		C	
	0.XX											±-				
ASME Y14.5	angular	0°	±°	cat. no.			-		Product - Customer Drw							
									sheet 3 of 3							