

LOC	DIST	REVISIONS			
P	LTR	DESCRIPTION	DATE	OWN	APVD
FT	0	Z	REVISED PER ECO-12-012316	05JUL12	KH MZ

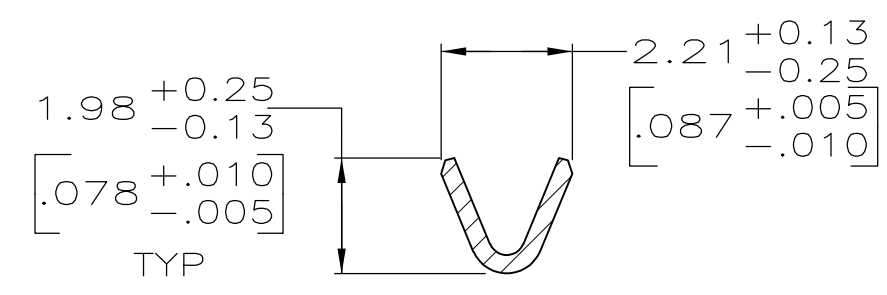
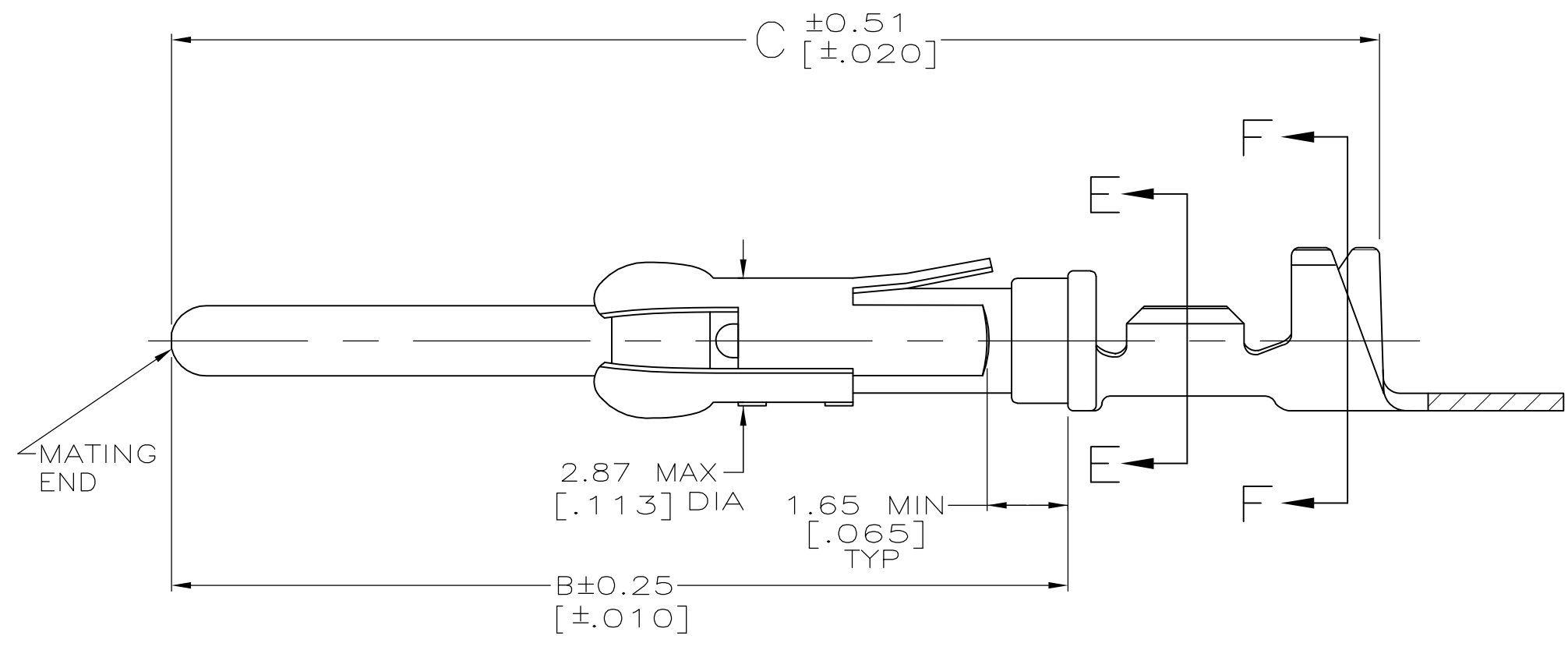
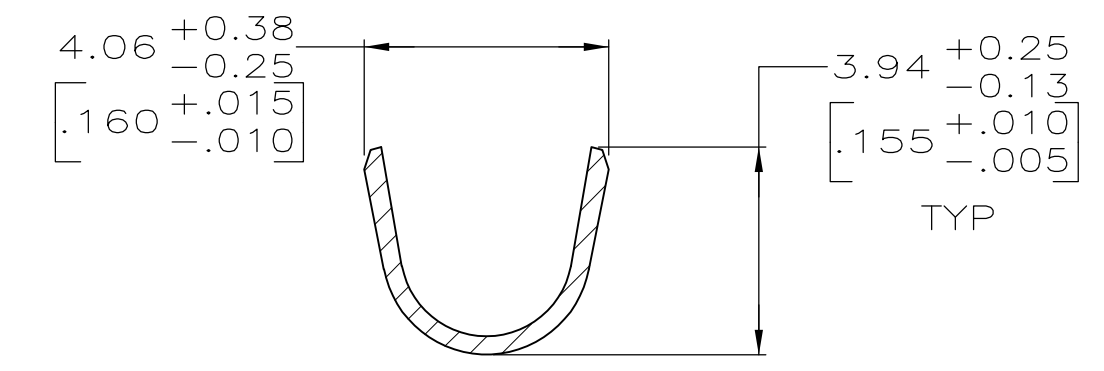
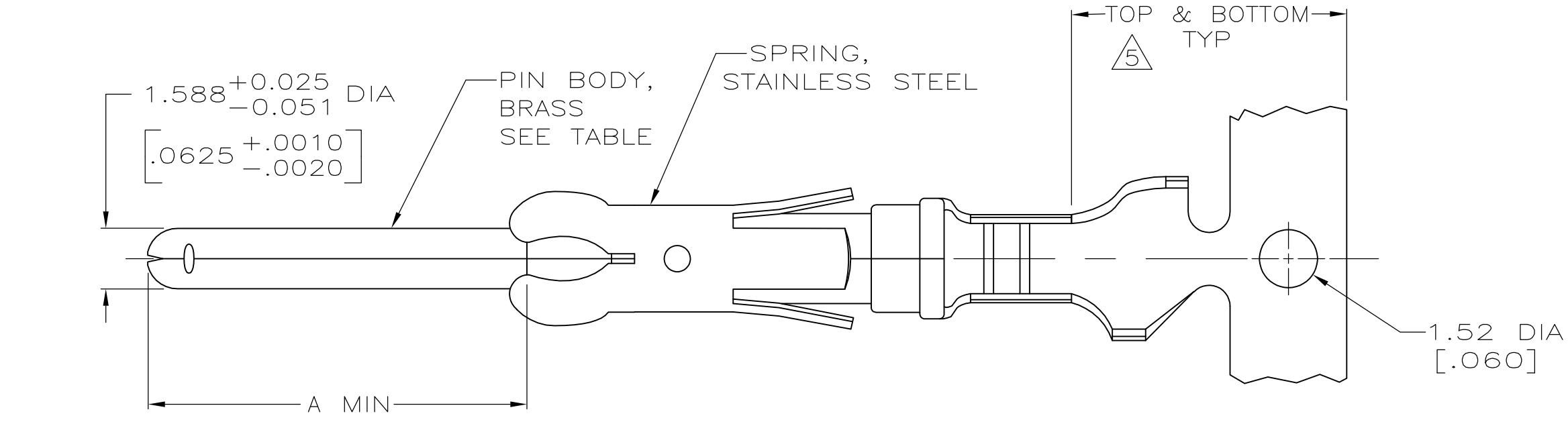

SECTION F-F

SECTION E-E

- 1 REVERSE REELED FOR MINI-APPLICATOR.
- 2 0.76 μ m [.000030] MIN PRECIOUS METAL PLATE ON MATING END FOR A LENGTH OF 5.08 [.200] MIN WITH 1.27 μ m [.000050] MIN MATTE TIN PLATE IN WIRE CRIMP AREA, BOTH OVER 1.27 μ m [.000050] MIN NICKEL PLATE. CONFORMS TO THE REQUIREMENTS OF TE CONNECTIVITY PRODUCT SPEC 108-10042, BASED ON EIA/ECA-364-1000.01A (CONTROLLED ENVIRONMENT APPLICATIONS).
- 3 0.76 μ m [.000030] MIN PRECIOUS METAL PLATE ON MATING END FOR A LENGTH OF 5.08 [.200] MIN WITH A UNIFORM GRADIENT TO 0.25 μ m [.000010] ON REMAINDER, OVER 1.27 μ m [.000050] MIN NICKEL PLATE. GOLD FLASH ALL OVER. CONFORMS TO THE REQUIREMENTS OF TE CONNECTIVITY PRODUCT SPEC 108-10042, BASED ON EIA/ECA-364-1000.01A (CONTROLLED ENVIRONMENT APPLICATIONS).
- 4 1.27 μ m [.000050] MIN TIN-LEAD PER MIL-T-10727 OVER 1.27 μ m [.000050] MIN NICKEL PER QQ-N-290.
- 5 GOLD PLATING NEED NOT APPEAR IN THIS AREA.
- 6. WIRE RANGE 24-20 AWG.
- 7. INSULATION RANGE 1.52[.060]-3.05[.120] DIA.
- 8 0.38 μ m [.000015] MIN GOLD PER MIL-G-45204 ON MATING END FOR A LENGTH OF 5.08 [.200] MIN, 1.27 μ m [.000050] MIN TIN-LEAD PER MIL-T-10727 FOR A LENGTH OF 5.69 [.224] MIN ON OPPOSITE END, BOTH OVER 1.27 μ m [.000050] MIN NICKEL PER QQ-N-290 ON ENTIRE CONTACT.
- 9 1.27 μ m [.000050] MIN TIN PER MIL-T-10727 OVER 1.27 μ m [.000050] MIN NICKEL PER QQ-N-290.

	27.10[1.067]	20.24[.797]	9.91[.390]	STANDARD	9	66566-7	1-66564-3
	27.10[1.067]	20.24[.797]	9.91[.390]	1	9	66566-7	1-66564-2
OBSOLETE	27.10[1.067]	20.24[.797]	9.91[.390]	1	8	66566-6	1-66564-1
OBSOLETE	30.78[1.212]	23.85[.939]	13.59[.535]	1	4	66566-5	1-66564-0
	27.10[1.067]	20.24[.797]	9.91[.390]	1	2	66566-4	66564-8
	27.10[1.067]	20.24[.797]	9.91[.390]	1	4	66566-2	66564-6
	27.10[1.067]	20.24[.797]	9.91[.390]	STANDARD	4	66566-2	66564-2
	27.10[1.067]	20.24[.797]	9.91[.390]	STANDARD	3	66566-1	66564-1
	C	B	A	REELING	PIN BODY FINISH	LOOSE PIECE REF	PART NO

THIS DRAWING IS A CONTROLLED DOCUMENT.

DWN	R.SHIREY	7-22-91
CHK	R.STONE	8-15-91
APVD	J.WESTMAN	6-19-91

STE TE Connectivity

PIN ASSEMBLY, .062, TYPE III+

SIZE	A2	CAGE CODE	00779	DRAWING NO	66564	RESTRICTED TO	-	
WEIGHT	-	CUSTOMER DRAWING	SCALE	8:1	SHEET	1 of 1	REV	Z