



LED Display Product Data Sheet LTD-4608BE-34J

Spec No.: DS30-2012-0075

Effective Date: 09/14/2012

Revision: -

LITE-ON DCC

RELEASE

BNS-OD-FC001/A4

LED DISPLAY

LTD-4608BE-34J
DATA SHEET

Rev	Description	By
01	RDR Original Spec	Phanomkorn May 15, 2012
-	NPPR Original Spec	Phanomkorn September 07, 2012

SPEC NO. : _____
 DATE : September 07, 2012
 REV. NO. : -
 PAGE NO. : 0 OF 6
 CUSTOMER APPROVAL : _____
 DATE : _____

LITEON LITE-ON TECHNOLOGY CORPORATION
Property of Lite-On Only

LED DISPLAY

LTD-4608BE-34J
DATA SHEET

Rev	Description	By
01	RDR Original Spec	Phanomkorn May 15, 2012

SPEC NO. : _____
 DATE : May 15, 2012
 REV. NO. : 01
 PAGE NO. : 0 OF 6
 CUSTOMER APPROVAL : _____
 DATE : _____

PART NO.: LTD-4608BE-34J PAGE: 0 of 6
 BNS-OD-C131/A4

2 of 6 - 9-6
 第 2 页 共 6 页 (9-6)
 (C) 2012 (4/4/12) 版印

FEATURES

- * 0.4 inch (10 mm) DIGIT HEIGHT.
- * CONTINUOUS UNIFORM SEGMENTS.
- * LOW POWER REQUIREMENT.
- * EXCELLENT CHARACTERS APPEARANCE.
- * HIGH BRIGHTNESS & HIGH CONTRAST.
- * WIDE VIEWING ANGLE.
- * SOLID STATE RELIABILITY.
- * CATEGORIZED FOR LUMINOUS INTENSITY.
- * LEAD-FREE PACKAGE (ACCORDING TO ROHS)

DESCRIPTION

The LTD-4608BE-34J is a 0.4 inch (10 mm) digit height dual digit seven-segment display. This device utilizes red orange LED chips, which are made from GaAsP on GaP substrate, and has a gray face and white segments.

DEVICE

PART NO.	DESCRIPTION
Red Orange	Duplex Common Anode
LTD-4608BE-34J	Rt. Hand Decimal

PACKAGE DIMENSIONS

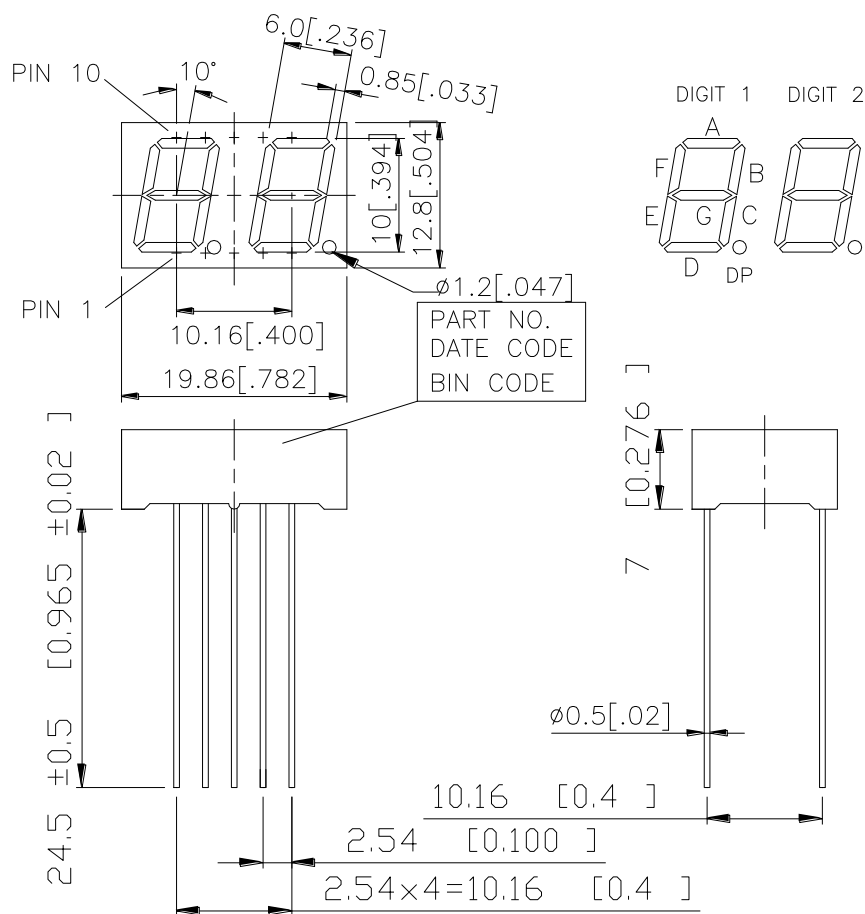

NOTES:

1. All dimensions are in millimeters. Tolerances are ± 0.25 mm (0.01") unless otherwise noted.
2. Pin tip's shift tolerance is ± 0.4 mm.
3. Foreign material on segment $\cong 10$ mils
4. Ink contamination (surface) $\cong 20$ mils
5. Bending $\cong 1/100$
6. Bubble in segment $\cong 10$ mils
7. Recommend the best PCB hole: diameter 1.0mm

INTERNAL CIRCUIT DIAGRAM

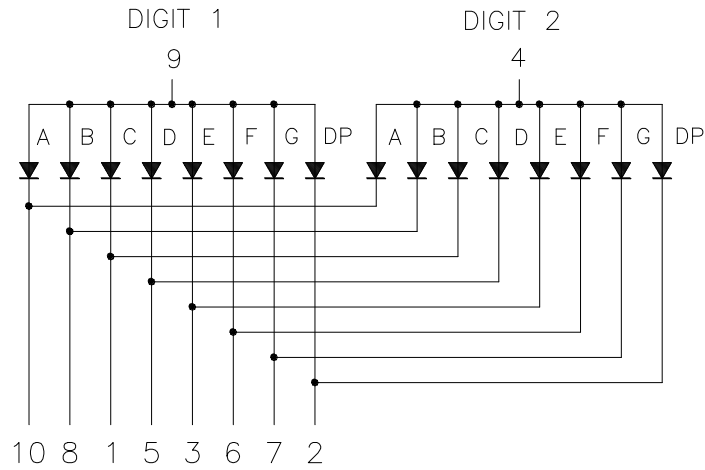

PIN CONNECTION

No.	CONNECTION
1	CATHODE C
2	CATHODE D.P.
3	CATHODE E
4	COMMON ANODE (DIGIT 2)
5	CATHODE D
6	CATHODE F
7	CATHODE G
8	CATHODE B
9	COMMON ANODE (DIGIT 1)
10	CATHODE A

ABSOLUTE MAXIMUM RATING AT Ta=25°C

PARAMETER	MAXIMUM RATING	UNIT
Power Dissipation Per Segment	75	mW
Peak Forward Current Per Segment (1/10 Duty Cycle, 0.1ms Pulse Width)	100	mA
Continuous Forward Current Per Segment	25	mA
Derating Linear From 25°C Per Segment	0.28	mA/°C
Reverse Voltage Per Segment	5	V
Operating Temperature Range	-35°C to +105°C	
Storage Temperature Range	-35°C to +105°C	
Soldering Conditions: 1/16 inch below seating plane for 3 seconds at 260°C or of temperature unit (during assembly) not over max. temperature rating above.		

ELECTRICAL / OPTICAL CHARACTERISTICS AT Ta=25°C

PARAMETER	SYMBOL	MIN.	TYP.	MAX.	UNIT	TEST CONDITION
Average Luminous Intensity	I _v	800	2200		μcd	I _F =10mA
Peak Emission Wavelength	λ _p		630		nm	I _F =20mA
Spectral Line Half-Width	Δλ		40		nm	I _F =20mA
Dominant Wavelength	λ _d		621		nm	I _F =20mA
Forward Voltage Per Segment	V _F		2.0	2.6	V	I _F =20mA
Reverse Current Per Segment	I _R			100	μA	V _R =5V
Luminous Intensity Matching Ratio (Similar Light Area)	I _{v-m}			2:1		I _F =10mA

Note: 1. Luminous Intensity is measured with a light sensor and filter combination that approximates the CIE (Commision Internationale De L'Eclairage) eye-response curve.

2. Cross talk specification ≅ 2.5%

3. Reverse voltage is only for IR test. It cannot continue to operate at this situation.

BIN TABLE 2-1 FOR LUMINOUS INTENSITY

BIN GRADE	H1	H2	J1	J2	K1	K2	L1	L2	M1	M2
RANGE(μcd) I _F =10mA	801-1020	1021-1300	1301-1650	1651-2100	2101-2680	2681-3400	3401-4300	4301-5400	5401-6850	6851-8600

The Luminous Intensity Tolerance ±15percentage

TYPICAL ELECTRICAL / OPTICAL CHARACTERISTIC CURVES

(25°C Ambient Temperature Unless Otherwise Noted)

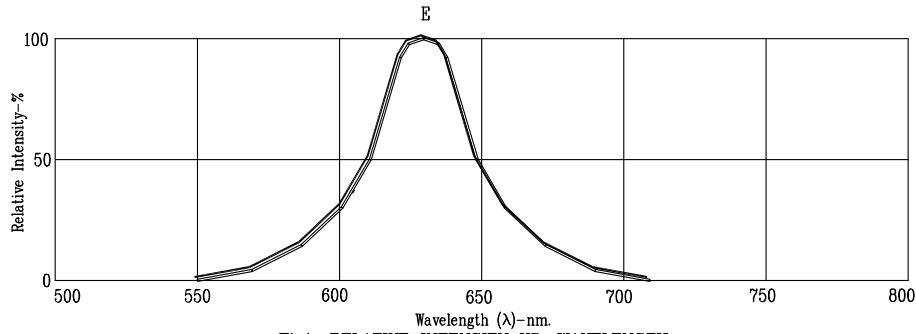

Fig1. RELATIVE INTENSITY VS. WAVELENGTH

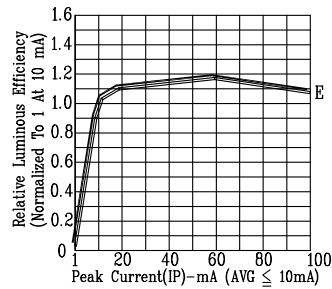

Fig2. RELATIVE LUMINOUS EFFICIENCY (LUMINOUS INTENSITY PER UNIT CURRENT) VS. PEAK CURRENT (REFRESH RATE 1KHz)

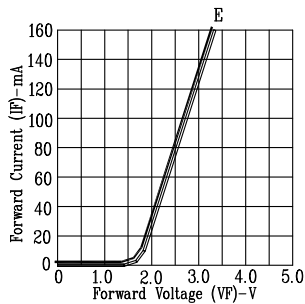

Fig3. FORWARD CURRENT VS. FORWARD VOLTAGE

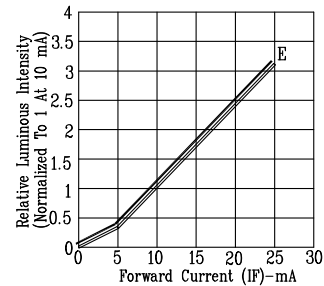

Fig4. RELATIVE LUMINOUS INTENSITY VS. FORWARD CURRENT

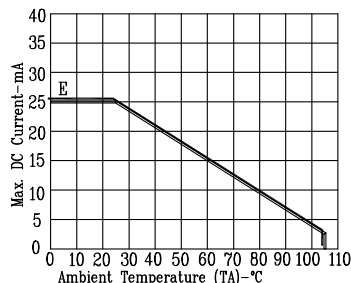

Fig5. MAX. ALLOWABLE DC CURRENT VS. AMBIENT TEMPERATURE.

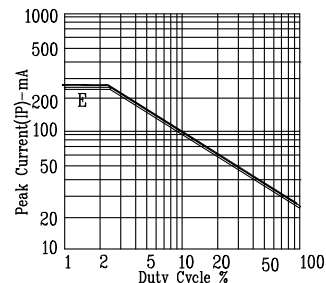
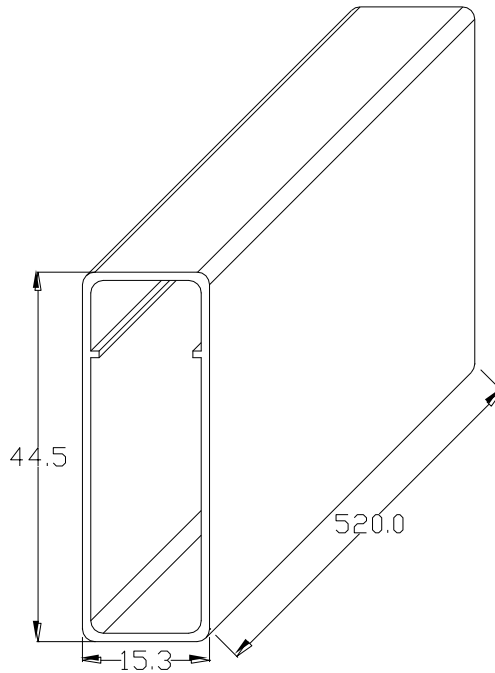

Fig6. MAX. PEAK CURRENT VS. DUTY CYCLE % (REFRESH RATE 1KHz)

NOTE: E=RED ORANGE

PACKING SPEC

Units / Tube: 24



Tubes / Inner Carton: 33
Units / Inner Carton: 792

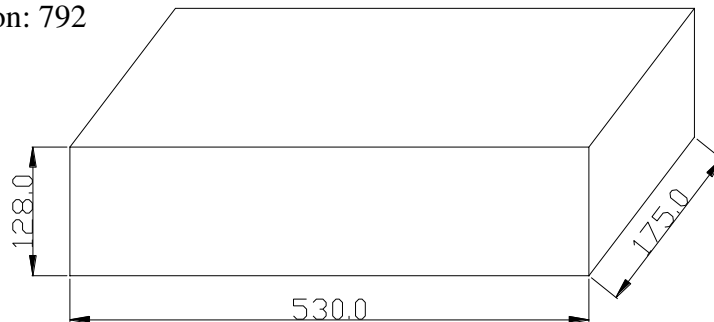

Tubes / Outer Carton: 132
Units / Outer Carton: 3168

