

REV.	DATE	ECR NO.	DESCRIPTION
NC	02/20/03	XXXX	INITIAL RELEASE
A	08/15/04	XXXX	UPDATE DRAWING FORMAT/MODIFY CONTACT PIN
B	02/19/13	2450	CORRECT I.D. OF CONTACT PIN, CORRECT PART DESCRIPTION, UPDATE DRAWING FORMAT

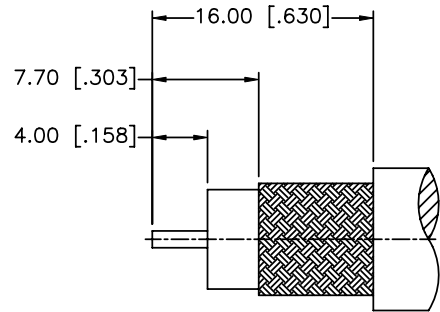

RECOMMENDED
CABLE STRIPPING DIM'S

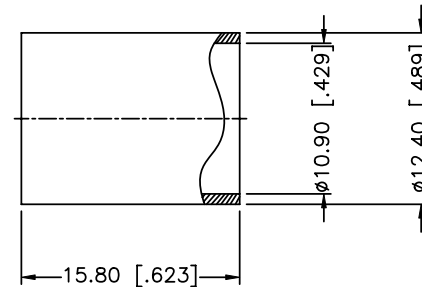
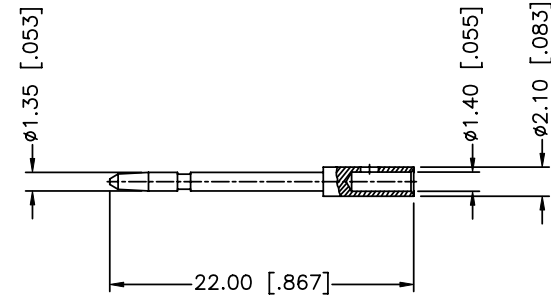
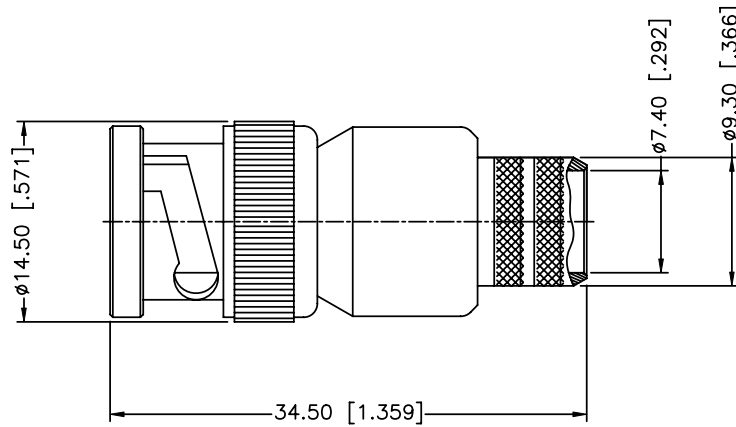

1. IMPEDENCE:75 OHM
2. FREQUENCE RANGE:DC-4 GHz
3. DIELECTRIC WITHSTANDING VOLTAGE:1500 VRMS
4. INSULATION RESISTANCE:5000 MOHMS MIN.
5. DURABILITY:500 CYCLES
6. CRIMPED FERRULE HEX CRIMP SIZE .429"
7. CRIMPED CONTACT PIN HEX CRIMP SIZE .068"
8. TEMPERATURE RANGE:-65°C TO +165°C

DESCRIPTION	MATERIAL	FINISH	QTY
10 FERRULE	BRASS	NICKEL	1
9 CONTACT PIN	BRASS	GOLD	1
8 SHELL	BRASS	NICKEL	1
7 GASKET	RUBBER	RED	1
6 RETAINER RING	BRASS	NICKEL	1
5 SPRING	SK5	NICKEL	1
4 WASHER	BRASS	NICKEL	1
3 BARREL	BRASS	NICKEL	1
2 INSULATOR	PTFE	NATURAL	1
1 BODY	BRASS	NICKEL	1

UNLESS OTHERWISE SPECIFIED DIMENSIONS ARE IN MILLIMETERS. DIMENSIONS IN [] ARE IN INCHES AND FOR CUSTOMER REFERENCE ONLY.
 UNLESS OTHERWISE SPECIFIED TOLERANCES FOR MILLIMETERS ARE:
 <0.5 ± 0.05mm
 0.5 - 6mm ± 0.10mm
 6 - 30mm ± 0.20mm
 30 - 120mm ± 0.30mm
 ANGLES ± 1°
 UNLESS OTHERWISE SPECIFIED TOLERANCES FOR INCHES ARE:
 <.020 ± 0.002"
 .020 - .236 ± 0.004"
 .236 - 1.180 ± 0.007"
 1.180 - 4.724 ± 0.012"
 ANGLES ± 1°
 DO NOT SCALE DRAWING

APPROVALS	DATE
DRAWN J.JI	02/19/13
CHECKED	
ISSUED	
SHEET 1 OF 1	
CAD FILE Y:/CONNEX/112576.DWG	

PART DESCRIPTION			
Amphenol Connex			
BNC CRIMP PLUG FOR M17/6-RG11 CABLE			
PART NO.		112576	
DWG. NO.	REV.	SIZE	SCALE
112576	B	A	NA