



## PM6641

### Monolithic VR for chipset and DDR2/3 supply for ultra-mobile PC (UMPC) applications

#### Features

- 0.8 V  $\pm$ 1% internal voltage reference
- 2.7 V to 5.5 V input voltage range
- Fast response, constant frequency, current mode control
- Three independent, adjustable, out-of-phase SMPS for DDR2/3 (VDDQ) and chipset supply
- Low noise DDR2/3 reference (VTTREF)
- $\pm$ 2 Apk LDO for DDR2/3 termination (VTT) with foldback
- S0-S5 states compliant DDR2/3 section
- Active soft-end for all outputs
- Selectable tracking discharge for VDDQ
- Separate Power Good signals
- Pulse skipping at light load
- Programmable current limit and soft-start for all outputs
- Latched OVP, UVP protection
- Thermal protection

#### Applications

- DDR2/3 memory and chipset supply
- UMPC and portable equipment
- Handheld and PDAs

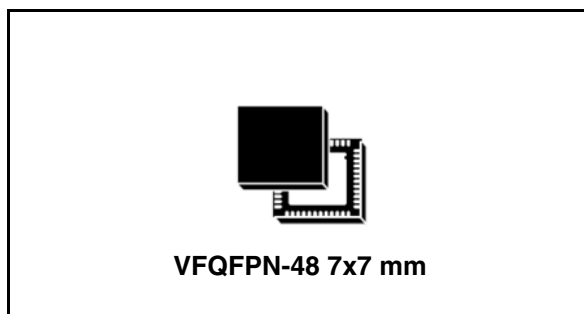

#### Description

The PM6641 is a monolithic voltage regulator module specifically designed to supply DDR2/3 memory and chipset in ultra-mobile PC and real estate constrained portable systems.

It integrates three independent, adjustable, constant frequency buck converters, a  $\pm$ 2 Apk low drop-out (LDO) linear regulator and a  $\pm$ 15 mA low noise buffered reference.

Each regulator provides basic UV and OV protections, programmable soft-start and current limit and active soft-end.

Pulse-skipping technique is performed to increase efficiency at very light load.

Table 1. Device summary

Order codes	Package	Packaging
PM6641	VFQFPN-48 7x7 (exposed pad)	Tray
PM6641TR		Tape and reel

# Contents

- 1      Typical application circuit ..... 3**
- 2      Pin settings ..... 4**
  - 2.1    Connections ..... 4
  - 2.2    Pin description ..... 5
- 3      Electrical data ..... 7**
  - 3.1    Maximum rating ..... 7
  - 3.2    Thermal data ..... 7
  - 3.3    Recommended operating conditions ..... 8
- 4      Electrical characteristics ..... 9**
- 5      Typical operating characteristics ..... 13**
- 6      Block diagram ..... 17**
- 7      Device description ..... 18**
  - 7.1    Memory supply ..... 19
    - 7.1.1    VDDQ switching regulator ..... 19
    - 7.1.2    VTT LDO and VTTREF buffered reference ..... 20
    - 7.1.3    VTT and VTTREF soft-start ..... 20
    - 7.1.4    S3 and S5 power management pins ..... 21
  - 7.2    Chipset supply ..... 21
  - 7.3    SW regulators control loop ..... 23
  - 7.4    SW regulators pulse skipping and PWM mode ..... 25
  - 7.5    Output voltage divider ..... 26
  - 7.6    Outputs soft-start ..... 27
  - 7.7    Outputs soft-end ..... 28
  - 7.8    Switching frequency selection ..... 28
  - 7.9    Phase management ..... 29
  - 7.10    Peak current limit ..... 30
  - 7.11    Fault management ..... 32

---

7.11.1	Output overvoltage . . . . .	32
7.11.2	Output under voltage . . . . .	32
7.11.3	Thermal shutdown . . . . .	33
7.11.4	Input under voltage lock-out . . . . .	33
<b>8</b>	<b>Components selection . . . . .</b>	<b>34</b>
8.1	Inductor selection . . . . .	34
8.2	Input capacitor selection . . . . .	35
8.3	Output capacitor selection . . . . .	36
8.4	SW regulator compensation components selection . . . . .	37
8.5	Layout guidelines . . . . .	39
<b>9</b>	<b>Application examples . . . . .</b>	<b>40</b>
9.1	UMPC DDR2 and chipset power supply . . . . .	40
<b>10</b>	<b>Package mechanical data . . . . .</b>	<b>43</b>
<b>11</b>	<b>Revision history . . . . .</b>	<b>45</b>



## 2 Pin settings

### 2.1 Connections

Figure 2. Pin connection (through top view)

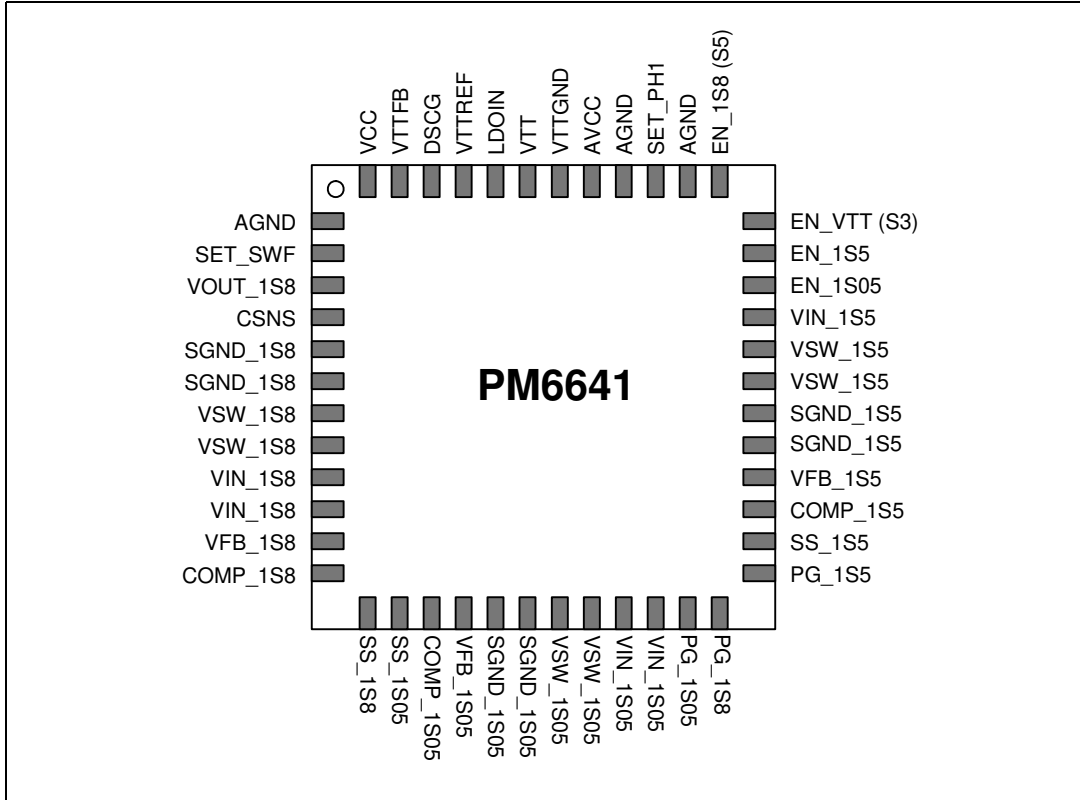

## 2.2 Pin description

**Table 2. Pin functions**

n°	Pin	Function
1	AGND	Analog and signal ground.
2	SET_SWF	Switching frequency setting input. See <a href="#">Chapter 7.8: Switching frequency selection on page 29</a>
3	VOUT_1S8	VDDQ/2 divider input and discharge path for 1.8 V rail.
4	CSNS	Current limit setting input for all rails. See <a href="#">Chapter 7.10: Peak current limit on page 31</a>
5	SGND_1S8	Switcher power ground for 1.8 V rail.
6	SGND_1S8	Switcher power ground for 1.8 V rail.
7	VSW_1S8	Switch node for 1.8 V rail.
8	VSW_1S8	Switch node for 1.8 V rail.
9	VIN_1S8	Power supply input for 1.8 V rail.
10	VIN_1S8	Power supply input for 1.8 V rail.
11	VFB_1S8	Feedback input for 1.8 V rail. See <a href="#">Chapter 7.5: Output voltage divider on page 27</a>
12	COMP_1S8	Loop compensation output for 1.8 V rail. See <a href="#">Chapter 7.3: SW regulators control loop on page 24</a> and <a href="#">Chapter 8.4: SW regulator compensation components selection on page 38</a> sections for details.
13	SS_1S8	Positive terminal of the external soft-start capacitor for 1.8 V rail. See <a href="#">Chapter 7.6: Outputs soft-start on page 28</a> section for details.
14	SS_1S05	Positive terminal of the external soft-start capacitor for 1.05 V rail. See <a href="#">Chapter 7.6: Outputs soft-start on page 28</a> section for details.
15	COMP_1S05	Loop compensation output for 1.05 V rail. See <a href="#">Chapter 7.3: SW regulators control loop on page 24</a> and <a href="#">Chapter 8.4: SW regulator compensation components selection on page 38</a> for details.
16	VFB_1S05	Feedback input for 1.05 V rail. See <a href="#">Chapter 7.5: Output voltage divider on page 27</a> section for details
17	SGND_1S05	Switcher power ground for 1.05 V rail.
18	SGND_1S05	Switcher power ground for 1.05 V rail.
19	VSW_1S05	Switch node for 1.05 V rail.
20	VSW_1S05	Switch node for 1.05 V rail.
21	VIN_1S05	Power supply input for 1.05 V rail.
22	VIN_1S05	Power supply input for 1.05 V rail.
23	PG_1S05	Power Good signal for 1.05 V rail. Open drain. See <a href="#">Chapter 7.2: Chipset supply on page 22</a> section for details.
24	PG_1S8	Power Good signal for 1.8 V rail. Open drain. See <a href="#">Chapter 7.1.1: VDDQ switching regulator on page 20</a> section for details.
25	PG_1S5	Power Good signal for 1.5 V rail. Open drain. See <a href="#">Chapter 7.2: Chipset supply on page 22</a> section for details.

**Table 2. Pin functions (continued)**

n°	Pin	Function
26	SS_1S5	Positive terminal of the external soft-start capacitor for 1.5 V rail. See <a href="#">Chapter 7.6: Outputs soft-start on page 28</a> section for details.
27	COMP_1S5	Loop compensation output for 1.5 V rail. <a href="#">Chapter 7.3: SW regulators control loop on page 24</a> and <a href="#">Chapter 8.4: SW regulator compensation components selection on page 38</a> sections for details.
28	VFB_1S5	Feedback input for 1.5 V rail. See <a href="#">Chapter 7.5: Output voltage divider on page 27</a> section for details
29	SGND_1S5	Switcher power ground for 1.5 V rail.
30	SGND_1S5	Switcher power ground for 1.5 V rail.
31	VSW_1S5	Switch node for 1.5 V rail.
32	VSW_1S5	Switch node for 1.5 V rail.
33	VIN_1S5	Power supply input for 1.5 V rail.
34	EN_1S05	Enable input for 1.05 V rail.
35	EN_1S5	Enable input for 1.5 V rail.
36	EN_VTT	Enable input for VTT rail. High in S0 system states. See <a href="#">Chapter 7.1.4: S3 and S5 power management pins on page 22</a> section for details.
37	EN_1S8	Enable input for 1.8 V (VDDQ) rail. High in S0-S3 system states. See <a href="#">Chapter 7.1.4: S3 and S5 power management pins on page 22</a> section for details.
38	AGND	Analog and signal ground.
39	SET_PH1	Switching regulator phase control. See <a href="#">Chapter 7.9: Phase management on page 30</a> section for details.
40	AGND	Analog and signal ground.
41	AVCC	Analog circuitry supply. Connect to +5 V by a simple RC filter.
42	VTTGND	LDO linear regulator power ground.
43	VTT	LDO linear regulator output. DDR2-3 termination voltage. See <a href="#">Chapter 7.1: Memory supply on page 20</a> and <a href="#">Chapter 7.1.2: VTT LDO and VTTREF buffered reference on page 21</a> sections for details.
44	LDOIN	LDO linear regulator input. Typically connected to the 1.8 V rail.
45	VTTREF	Reference voltage buffer output. See <a href="#">Chapter 7.1: Memory supply on page 20</a> and <a href="#">Chapter 7.1.2: VTT LDO and VTTREF buffered reference on page 21</a> sections for details.
46	DSCG	Tracking/non-tracking discharge selection for DDR2-3 section. See <a href="#">Chapter 7.7: Outputs soft-end on page 29</a> section for details.
47	VTTFB	Feedback input for VTT linear regulator output.
48	VCC	+5 V switching circuitry supply. Bypass to AGND by a 100 nF capacitor.

## 3 Electrical data

### 3.1 Maximum rating

Table 3. Absolute maximum ratings <sup>(1)</sup>

Symbol	Parameter	Value	Unit
$V_{VIN}$	VIN_x to SGND_x	-0.3 to 6	V
$V_{VCC}$	VCC to AGND or SGND_x		
$V_{AVCC}$	AVCC to AGND or SGND_x		
	AGND to SGND_x	-0.3 to 0.3	
	VTTGND to SGND_x		
$V_{VSW}$	VSW_x to SGND_x	-0.3 to 6	
	VSW_x to AGND		
	CSNS, PG_x, EN_x, DSCG, COMP_x, VFB_x, SS_x, SET_SWF, SET_PH1, VOUT_1S8 to AGND	-0.3 to $V_{AVCC} + 0.3$	
	VTT, VTTREF, VTTFB to AGND		
	LDOIN, VTT, VTTREF, VTTFB to VTTGND		
$P_{TOT}$	Power dissipation @ $T_A = 25\text{ °C}$	4	W

1. Free air operating conditions unless otherwise specified. Stresses beyond those listed under “absolute maximum ratings” may cause permanent damage to the device. Exposure to absolute maximum rated conditions for extended periods may affect device reliability.

### 3.2 Thermal data

Table 4. Thermal data

Symbol	Parameter	Value	Unit
$R_{thJA}$	Thermal resistance junction to ambient	25	°C/W
$T_{STG}$	Storage temperature range	-50 to 150	°C
$T_A$	Operating ambient temperature range	-40 to 85	°C
$T_J$	Junction operating temperature range	-40 to 125	°C



### 3.3 Recommended operating conditions

Table 5. Recommended operating conditions

Symbol	Parameter	Values			Unit
		Min	Typ	Max	
$V_{AVCC}$	AVCC voltage range	4.5		5.5	V
$V_{VCC}$	VCC IC supply voltage	4.5		$V_{AVCC}$	
$V_{IN}$	VIN_x input voltage range	2.7		$V_{VCC}$	

## 4 Electrical characteristics

$T_A = 0\text{ }^{\circ}\text{C}$  to  $85\text{ }^{\circ}\text{C}$ ,  $AVCC = 5\text{ V}$ ,  $VCC = 5\text{ V}$ ,  $VIN\_x = 3.3\text{ V}$  and LDOIN connected to 1.8 V output if not otherwise specified <sup>(a)</sup>.

**Table 6. Electrical characteristics**

Symbol	Parameter	Test condition	Values			Unit
			Min	Typ	Max	
<b>Supply section all rails</b>						
$I_{CC}$	AVCC+VCC operating current	$V_{VCC} = +5\text{ V}$ , all switching regulators active without load			3	mA
$I_{SHDN}$	Total shutdown current into $VIN\_x + AVCC + VCC$ pins	$V_{IN} = V_{AVCC} = V_{VCC} = +5\text{ V}$ , all $EN\_x$ low			10	$\mu\text{A}$
$UVLO_{th}$	AVCC under voltage lockout upper threshold		4.0	4.1	4.35	V
	AVCC under voltage lockout lower threshold		3.6	3.9	4.0	
	UVLO hysteresis		100			mV
<b>Error amplifier, FB AND SS – all rails</b>						
$V_{REF}$	Error amplifier reference voltage	$V_{AVCC} = V_{VCC} = 5\text{ V}$	792	800	808	mV
$I_{FB}$	FB input bias current	$V_{FB\_X} = 0.8\text{ V}$			25	nA
$I_{SS}$	Soft-start current	$V_{SS\_x} = 0.4\text{ V}$		10		$\mu\text{A}$
<b>Oscillator frequency</b>						
$f_{SW}$	Switching frequency	$R_{SETSWF} = 140\text{ k}\Omega$		500		kHz
		SET_SWF to VCC	675	750	825	
		$R_{SETSWF} = 70\text{ k}\Omega$		1000		
<b>Comp all rails</b>						
$g_m$	COMP_x transconductance			300		$\mu\text{S}$
<b>UVP/OVP protections and PGOOD signal (SMPS only) all rails</b>						
$OVP_{th}$	Overvoltage threshold		116	120	124	%
$UVP_{th}$	Undervoltage threshold		56	60	64	
$PG_{th}$	Power good upper threshold		106	110	115	
	Power Good lower threshold		86	90	94	
$I_{PG,LEAK}$	PG_x outputs leakage current	PG_x tied to +5 V			1	$\mu\text{A}$
$V_{PG,LOW}$	PG_x outputs low level	$V_{FB\_X} = 0.6\text{ V}$ or $1\text{ V}$ , $I_{PG\_X} = 2\text{ mA}$			250	mV

a. All parameters at operating temperature extremes are guaranteed by design and statistical analysis (not production tested).

Table 6. Electrical characteristics (continued)

Symbol	Parameter	Test condition	Values			Unit
			Min	Typ	Max	
<b>Thermal shutdown</b>						
$T_{SHDN}$	Thermal shutdown threshold			150		°C
	Thermal shutdown hysteresis			15		
<b>Switching node – chipset 1.5 V rail</b>						
$t_{Onmin}$	Minimum on-time			200		ns
$R_{DSon,HS}$	High side PMOS Ron			150	220	mΩ
$R_{DSon,LS}$	Low side NMOS Ron			100	160	
$I_{INLEAK}$	VIN_1S5 leakage current	$V_{AVCC} = V_{VCC} = +5\text{ V}$ , all EN_1S5 low	$V_{IN} = +5\text{ V}$ $V_{IN} = +3.3\text{ V}$		1	μA
	Peak current limit	$R_{CSNS} = 50\text{ k}\Omega$		3.9		A
<b>Soft-end section – chipset 1.5 V rail</b>						
	Discharge resistance			25		Ω
	LS turn-on VFB_1SX threshold with internal divider	VFB_S1X to OUT_X		0.29		V
	LS turn-on VFB_1SX threshold with external divider	VFB_S1X to external divider		0.16		
<b>Power management section – chipset 1.5 V rail</b>						
	EN_1S5 turn-off level	$V_{AVCC} = 5\text{ V}$		0.8		V
	EN_1S5 turn-on level				2	
<b>Switching node – chipset 1.05 V rail</b>						
$t_{Onmin}$	Minimum on-time			180		ns
$R_{DSon,HS}$	High side PMOS Ron			100	160	mΩ
$R_{DSon,LS}$	Low side NMOS Ron			70	110	
$I_{INLEAK}$	VIN_1S05 leakage current	$V_{AVCC} = V_{VCC} = +5\text{ V}$ , all EN_1S05 low	$V_{IN} = +5\text{ V}$ $V_{IN} = +3.3\text{ V}$		1	μA
					1	
	Peak current limit	$R_{CSNS} = 50\text{ k}\Omega$		5.1		A
<b>Soft end section – chipset 1.05 V rail</b>						
	Discharge resistance			25		Ω

Table 6. Electrical characteristics (continued)

Symbol	Parameter	Test condition	Values			Unit
			Min	Typ	Max	
	LS turn-on VFB_1SX threshold with internal divider	VFB_S1X to OUT_X		0.2		V
	LS turn-on VFB_1SX threshold with external divider	VFB_S1X to external divider		0.16		
<b>Power management section – chipset 1.05 V rail</b>						
	EN_1S05 turn-off level	V <sub>AVCC</sub> = +5 V	0.8			V
	EN_1S05 turn-on level				2	
<b>Switching node – DDR2/3 rails</b>						
t <sub>Onmin</sub>	Minimum on-time			200		ns
R <sub>Dson,HS</sub>	High side PMOS Ron			90	130	mΩ
R <sub>Dson,LS</sub>	Low side NMOS Ron			80	120	
I <sub>INLEAK</sub>	VIN_1S8 leakage current	V <sub>AVCC</sub> = V <sub>VCC</sub> = 5 V, all EN_1S8 low	V <sub>IN</sub> = +5 V		1	μA
			V <sub>IN</sub> = +3.3 V		1	
	Peak current limit	R <sub>CSNS</sub> = 50 kΩ		6.1		A
<b>Soft-end section – DDR2/3 rails</b>						
	VDDQ discharge resistance in non-tracking discharge mode			25		Ω
	VTTREF discharge resistance in non-tracking discharge mode			200		Ω
	VTTFB discharge resistance in non-tracking discharge mode			40		Ω
	V <sub>FB_1SX</sub> threshold for final tracking/Non-tracking discharge transition with internal divider	VFB_S1X to OUT_X		0.340		V
	V <sub>FB_1SX</sub> threshold for final tracking/Non-tracking discharge transition with external divider	VFB_S1X to external divider		0.160		V
<b>Power management section – DDR2/3 rails</b>						
	DSCG turn-off level	V <sub>AVCC</sub> = +5 V			1.5	V
	DSCG turn-on level		3.5			
	EN_1S8 (S5), EN_VTT (S3) Turn-Off Level	V <sub>AVCC</sub> = +5 V	0.8			
	EN_1S8 (S5), EN_VTT (S3) Turn-On Level				2	

Table 6. Electrical characteristics (continued)

Symbol	Parameter	Test condition	Values			Unit
			Min	Typ	Max	
<b>V<sub>TT</sub> LDO section – DDR2/3 rails</b>						
PG_VTT_TH	Power Good upper threshold		106	110	114	%
	Power Good lower threshold		86	90	94	%
I <sub>LDOIN,ON</sub>	LDO input bias current in full-ON state	EN_1S8 = EN_VTT = +5 V, no load on VTT		1	10	μA
I <sub>LDOIN,STR</sub>	LDO input bias current in suspend-to-RAM state	EN_1S8 = +5 V, EN_VTT = 0 V, no load on VTT			10	
I <sub>LDOIN,STD</sub>	LDO input bias current in suspend-to-disk state	EN_1S8 = EN_VTT = 0 V, no load on VTT			3	
I <sub>VTTFB, BIAS</sub>	VTTFB bias current	EN_1S8 = EN_VTT = +5 V, V <sub>VTTFB</sub> = V <sub>VOUT_1S8</sub> / 2			1	μA
I <sub>VTTFB, LEAK</sub>	VTTFB leakage current	EN_1S8 = +5 V, EN_VTT = 0 V, V <sub>VTTFB</sub> = V <sub>VOUT_1S8</sub> / 2			1	
I <sub>VTT,LEAK</sub>	VTT leakage current	EN_1S8 = +5 V, EN_VTT = 0 V, V <sub>VTT</sub> = V <sub>VOUT_1S8</sub> / 2	-10		10	
V <sub>VTT</sub>	LDO linear regulator output voltage (DDR2)	EN_1S8 = EN_VTT = +5 V, I <sub>VTT</sub> 0 A, V <sub>LDOIN</sub> = 1.8 V		0.9		V
	LDO linear regulator output voltage (DDR3)	EN_1S8 = EN_VTT = +5 V, I <sub>VTT</sub> = 0 A, V <sub>LDOIN</sub> = 1.5 V		0.75		
	LDO output accuracy respect to VTTREF, V <sub>LDOIN</sub> = 1.8 V		EN_1S8 = EN_VTT = +5 V, -1 mA < I <sub>VTT</sub> < 1 mA	-20		20
EN_1S8 = EN_VTT = +5 V, -1 A < I <sub>VTT</sub> < 1 A			-25		25	
EN_1S8 = EN_VTT = +5 V, -2 A < I <sub>VTT</sub> < 2 A			-35		35	
I <sub>VTT,CL</sub>	LDO source current limit	V <sub>VTT</sub> < 1.10*(V <sub>VOUT_1S8</sub> / 2)	2	2.3	3	A
		V <sub>VTT</sub> > 1.10*(V <sub>VOUT_1S8</sub> / 2)	1	1.25	1.5	
	LDO sink current limit	V <sub>VTT</sub> > 0.90*(V <sub>VOUT_1S8</sub> / 2)	-3	-2.3	-2	
		V <sub>VTT</sub> < 0.90*(V <sub>VOUT_1S8</sub> / 2)	-1.5	-1.25	-1	
<b>VTTREF section – DDR2/3 rails</b>						
V <sub>VTTREF</sub>	VTTREF output voltage	I <sub>VTTREF</sub> = 0A, V <sub>VOUT_1S8</sub> = 1.8 V		0.9		V
	VTTREF output voltage accuracy relative to V <sub>VOUT_1S8</sub> /2	-15 mA < I <sub>VTTREF</sub> < +15 mA, V <sub>VOUT_1S8</sub> = 1.8 V	-2		2	%
I <sub>VTTREF</sub>	VTTREF short circuit source current	V <sub>VOUT_1S8</sub> = 1.8 V, V <sub>VTTREF</sub> = 0 V		40		mA
	VTTREF short circuit sink current	V <sub>VOUT_1S8</sub> = 1.8 V, V <sub>VTTREF</sub> = 1.8 V		-40		

## 5 Typical operating characteristics

Figure 3. VDDQ and VTT soft-start without load

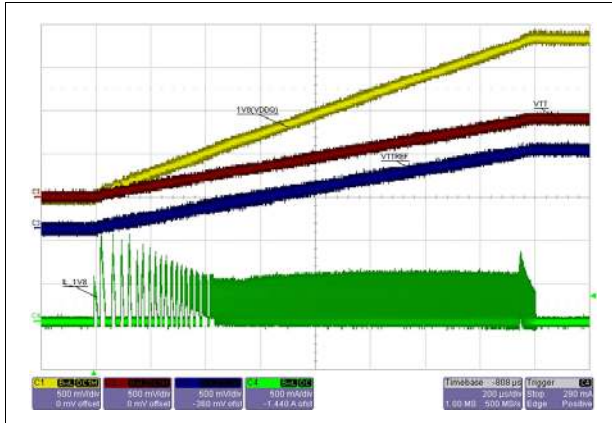

Figure 4. VDDQ and VTT soft-start with AVG load

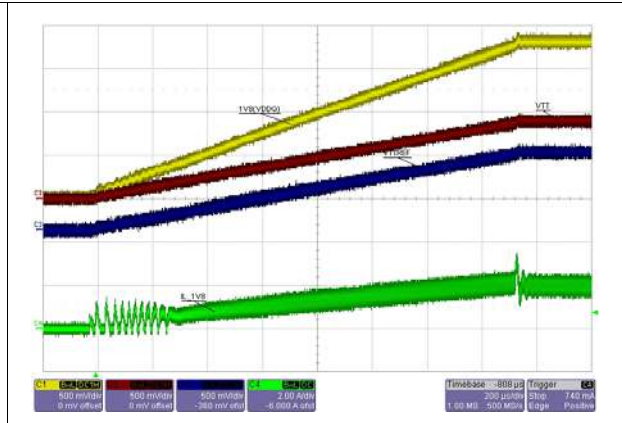

Figure 5. 1V5 soft-start without load

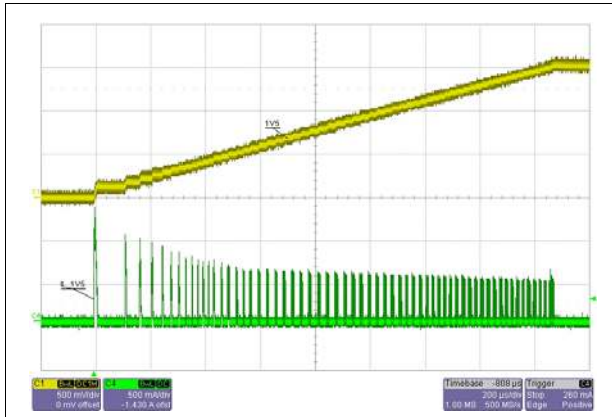

Figure 6. 1V5 soft-start with load

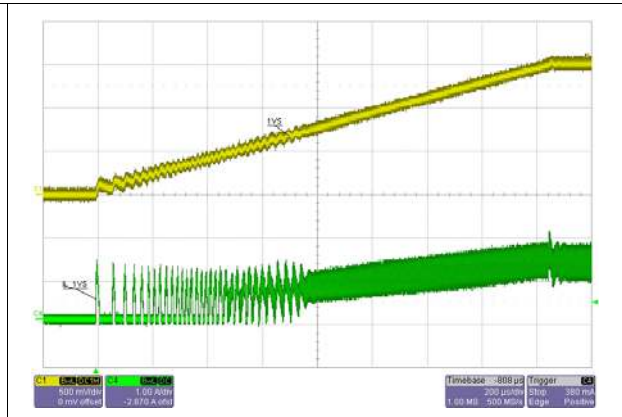

Figure 7. 1V05 soft-start without load

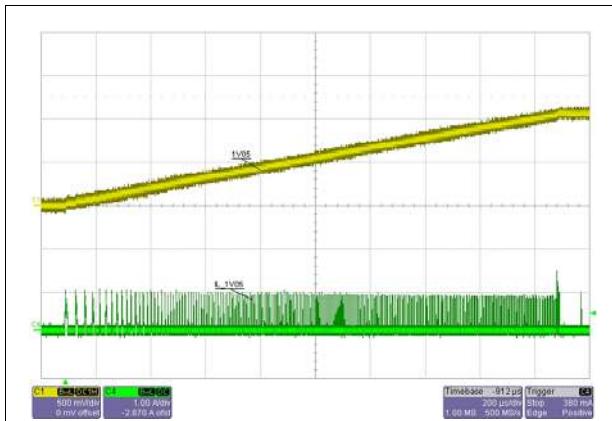

Figure 8. 1V05 soft-start without load

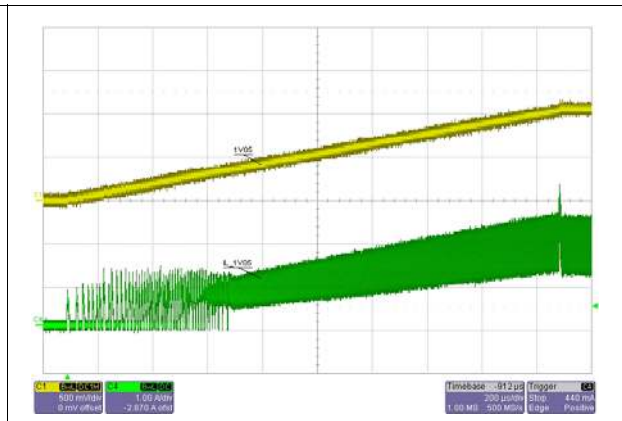

Figure 9. VDDQ output ripple and phase @ AVG current

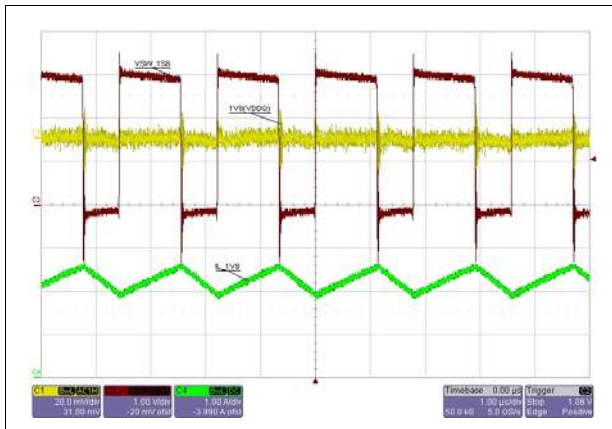

Figure 10. VTT, VTTREF output ripple @ AVG current

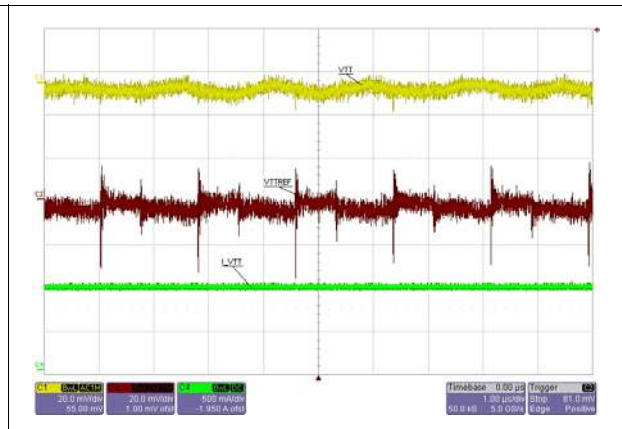

Figure 11. 1V5 output ripple and phase @ AVG current

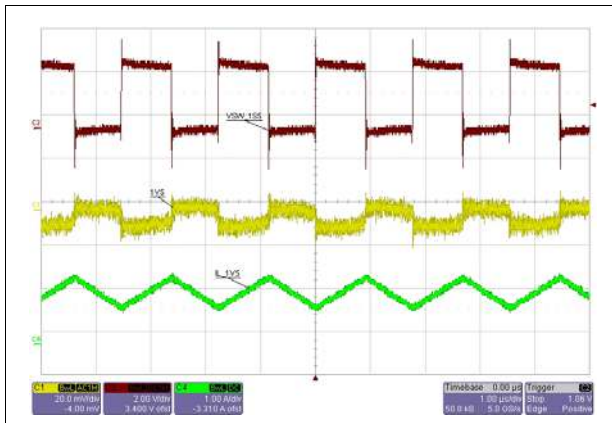

Figure 12. 1V05 output ripple and phase @ AVG current

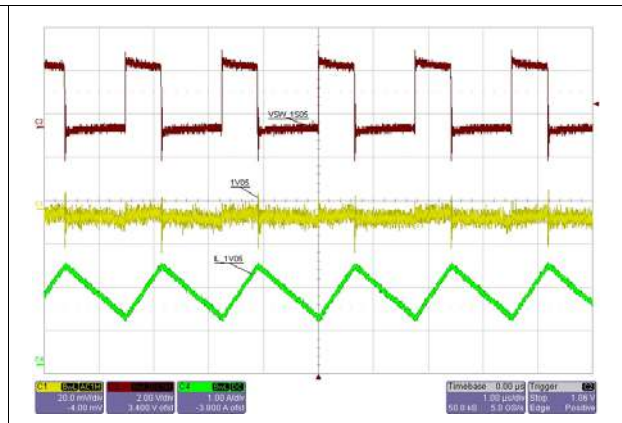

Figure 13. SW reg. efficiency @  $V_{IN} = 3.3\text{ V}$ ,  $F_{SW} = 600\text{ kHz}$

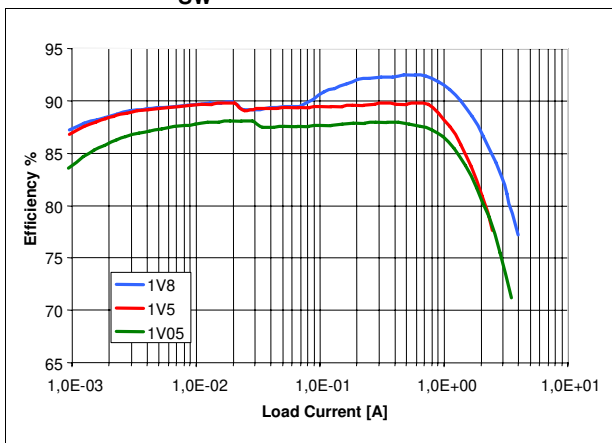

Figure 14. VDDQ (1.8 V) load regulation

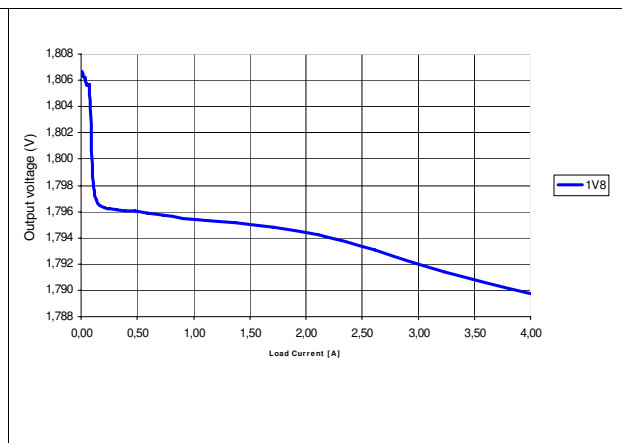

Figure 15. 1.5 V load regulation

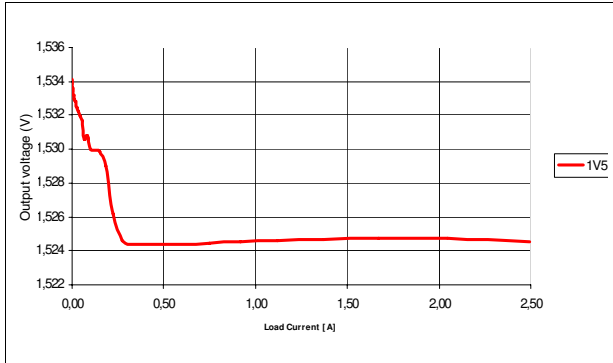

Figure 16. 1.05 V load regulation

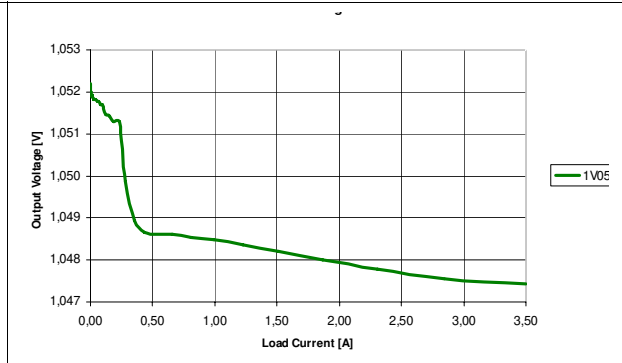

Figure 17. VDDQ (1.8 V) load transient: 0-AVG

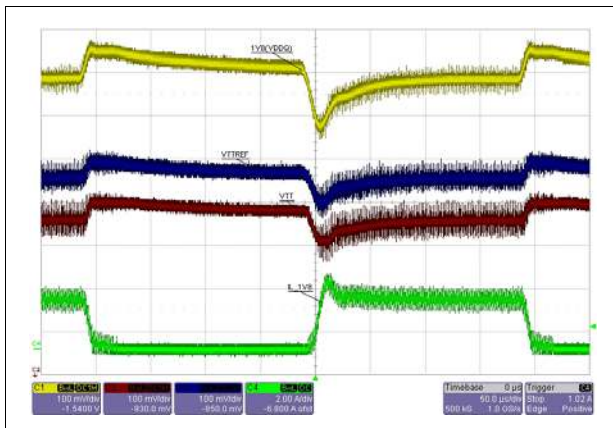

Figure 18. VTT load transient: -1 A +1 A

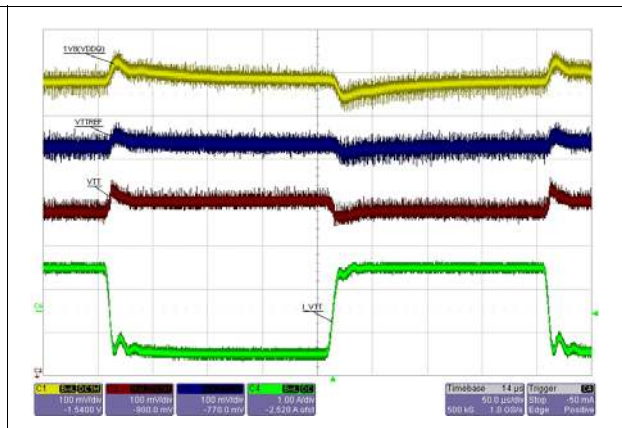

Figure 19. 1V5 load transient: 0-AVG

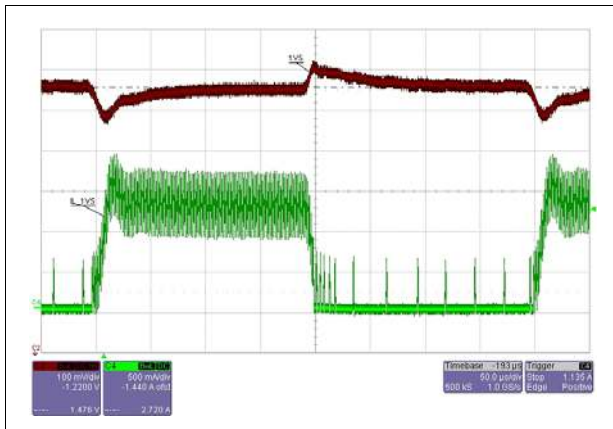

Figure 20. 1V05 load transient: 0-AVG

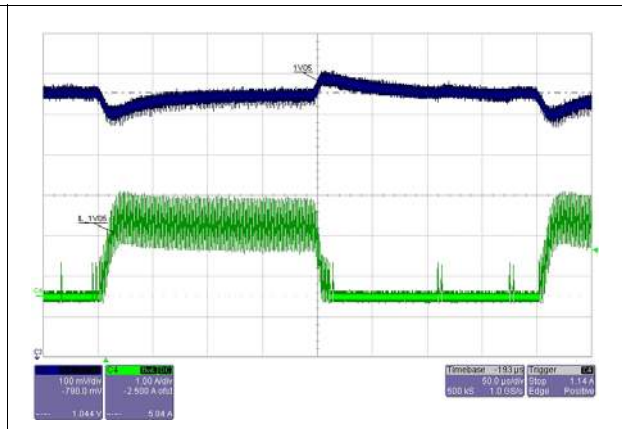



Figure 21. VDDQ e VTT soft-end with DSCG = AVCC

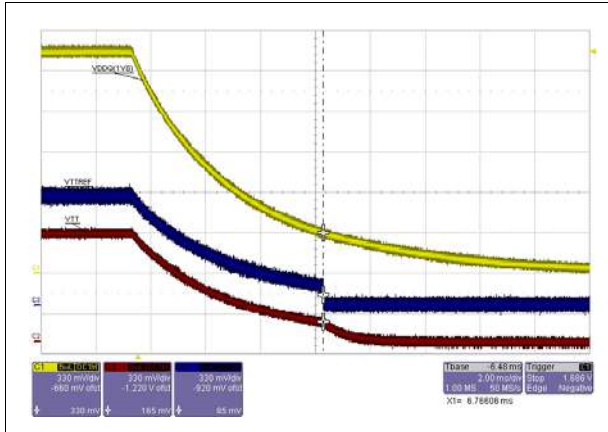

Figure 22. VDDQ e VTT soft-end with DSCG = AGND

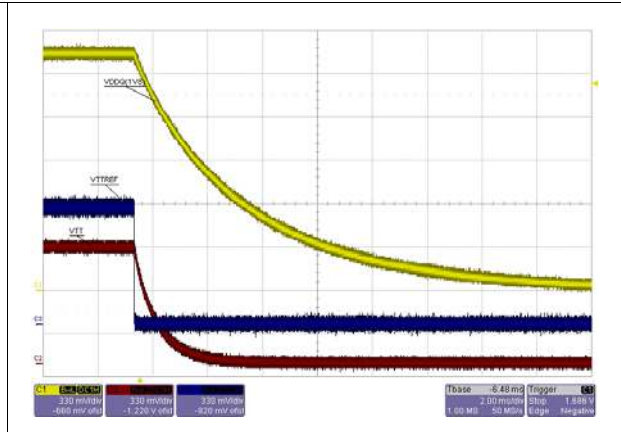

Figure 23. Current limit

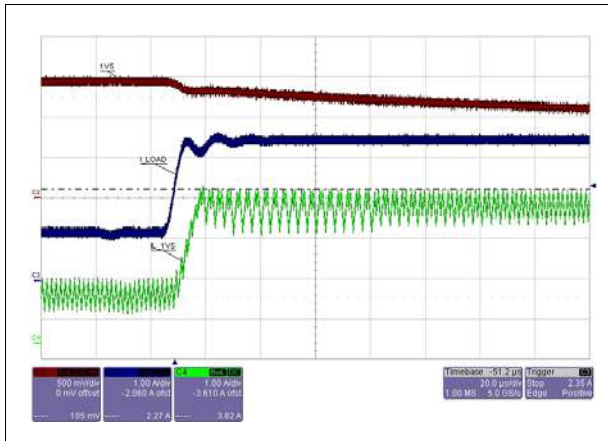

Figure 24. Soft-OV (1V05)

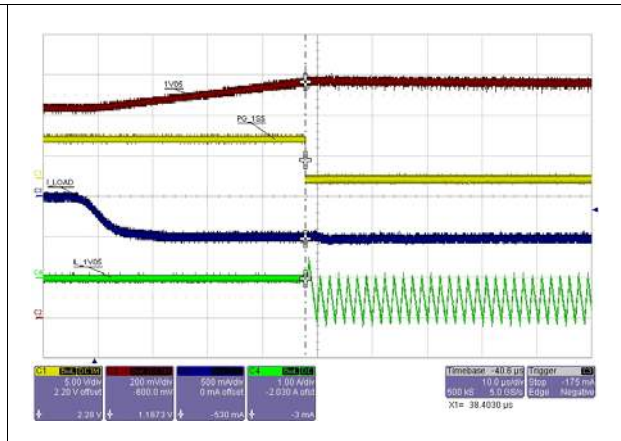

Figure 25. Output OV (1V5) @ R\_CSN5 = 1 MΩ

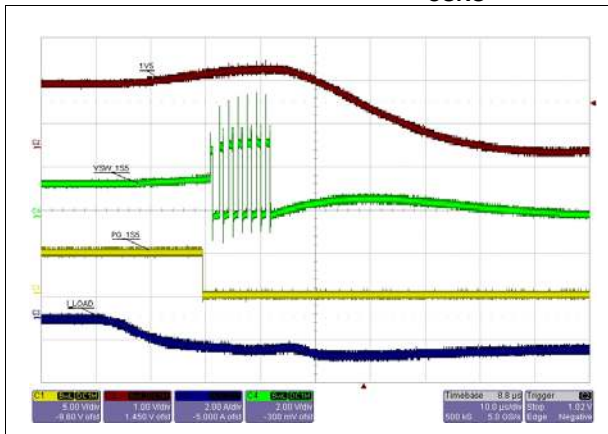
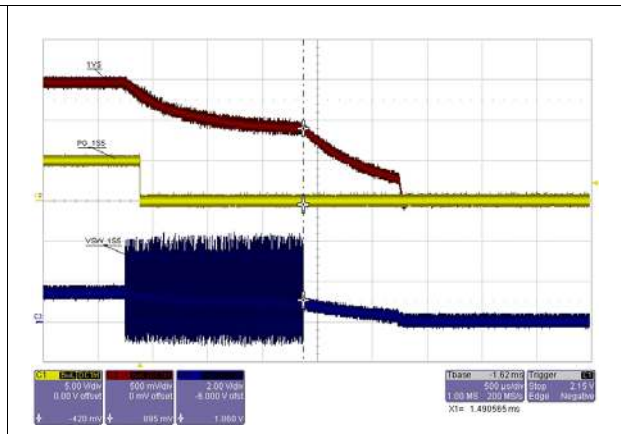

Figure 26. Output UV (1V5)



Note: All the above measures and screen captures are based on PM6641EVAL demonstration board. Refer to PM6641 demonstration kit for details.

# 6 Block diagram

Figure 27. Functional and block diagram

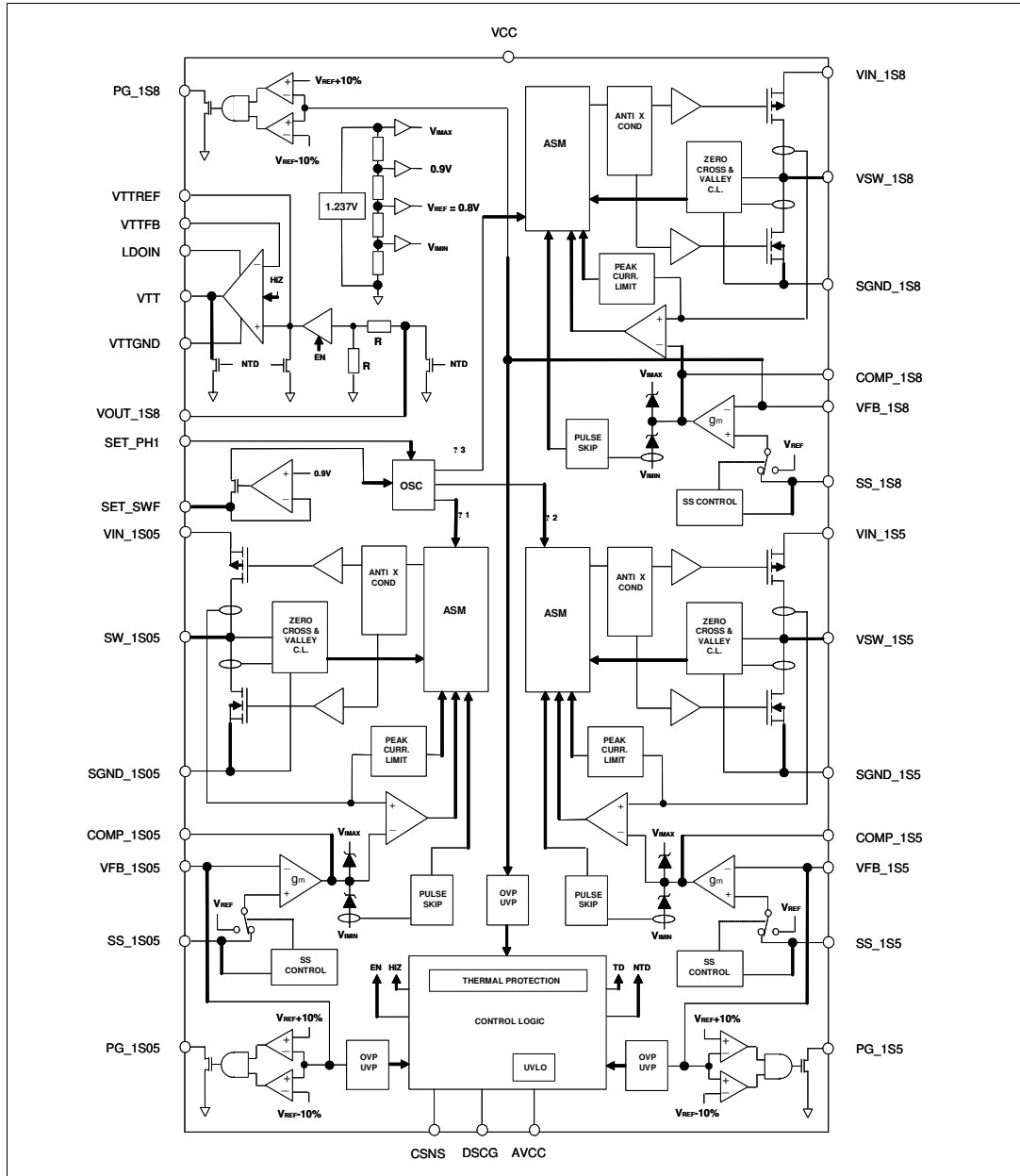

Table 7. Legend

<b>TD</b>	Tracking discharge enable
<b>NTD</b>	Non-tracking discharge enable
<b>EN</b>	VTTREF buffer enable
<b>HiZ</b>	LDO high impedance mode enable

## 7 Device description

The PM6641 is an integrated voltage regulator module designed to supply DDR2/3 memory and chipset I/O in real estate constrained portable equipment and ultra-mobile PCs. The device consists of three buck regulators (two for chipset supply and one for main DDR supply), a low drop-out (LDO) linear regulator capable of  $\pm 2$  Apk (DDR termination voltage) and a low noise buffered reference (DDR input buffer reference). It has been developed for single-series Li-Ion battery stack powered equipment, allowing an input power supply from 2.7 V up to 5.5 V.

The PM6641 provides a compact solution by integrating DDR and chipset voltage regulators on a single IC with internal power MOSFETs and requiring a minimum number of external components. All its buck regulators are based on a current-mode control scheme with integrated features to guarantee stability and fast load transient response. Each regulator output voltage can be adjusted or a pre-fixed output voltage can be chosen, if external components are unwanted. Each switching regulator has independent programmable soft-start, to reduce inrush current, and output soft-end, to avoid inductor and MOSFETs high peak current.

Other buck regulators features include output over-voltage and under-voltage protections, programmable current limit and output Power Good signals high efficiency is achieved over a wide range of load conditions by using a pulse-skipping technique at light load.

The PM6641 can detect the AVCC pin under-voltage through the under-voltage lock-out (UVLO) block and it is able to limit its internal temperature through its auto-recovery thermal shutdown.

The switching frequency of the buck controllers can be set in the range 500 kHz-1 MHz with an external resistor or can be set equal to 750 kHz without external components use. All buck regulators work at the same switching frequency with selectable phase shift.

The regulators can support both electrolytic and ceramic output capacitors because no minimum output voltage ripple is required for stability purposes.

The PM6641 is provided in a QFN7x7 mm 48-pin lead-free package.

## 7.1 Memory supply

The DDR2/3 section of PM6641 is based on the VDDQ rail, the VTT termination rail and the VTTREF reference voltage buffer.

The VDDQ rail is provided by a step-down switching regulator whose output voltage, by default, is set to 1.8 V, in order to be compliant with DDR2 JEDEC specs. The output voltage can also be adjusted using an external resistor divider. This rail performs latched output under-voltage and over-voltage and auto-recovery current limit, without requiring external sensing resistor.

The VTT termination rail is supplied by a low drop-out (LDO) linear regulator, able to sink and source up to 2 A peak current. This regulator follows the half of the VDDQ rail and is a replica of the VTTREF reference voltage buffer. When LDOIN is directly supplied by VDDQ, i.e. the PM6641 1S8 rail, VTT and VDDQ can perform the so called tracking discharge, in compliance with the JEDEC specs, as described in the following section. If higher efficiency is required, VTT can be supplied by a lower voltage rail. An output capacitor of at least 20  $\mu\text{F}$  is the only external component required.

The VTTREF reference voltage buffer is always in tracking with the half of VDDQ and is able to sink and source up to 15 mA with an accuracy of  $\pm 2\%$  relative to VDDQ half. A 10 nF up to 100 nF bypass capacitor for stability purposes is required.

### 7.1.1 VDDQ switching regulator

The VDDQ rail is provided by a constant frequency current-mode buck regulator, whose frequency is set by inserting an external resistor between SET\_SWF pin and AGND (see [Chapter 7.8: Switching frequency selection on page 29](#) section for details). The output voltage can easily be set to 1.8 V by connecting the feedback pin VFB\_1S8 directly to the output rail, avoiding the use of external components. However, if a different output voltage is desired, the VFB\_1S8 pin must be connected to the central tap of a resistor divider. The output voltage can be adjusted from 0.8 V up to the input voltage value, decreased by a drop due to the high-side MOSFET on resistance.

(see [Chapter 7.5: Output voltage divider on page 27](#) section for details).

The control loop needs to be compensated by inserting a resistor-capacitor series connected between the COMP\_1S8 pin and ground; if electrolytic capacitor with relevant equivalent series resistance (ESR) are used, an additional capacitor between the COMP\_1S8 pin and ground can be useful (see [Chapter 7.3: SW regulators control loop on page 24](#) section for details). The classical slope compensation is internally implemented and no external components are required.

The internal high-side PMOS and low-side NMOS allow the regulator to source an average current of 2.8 A and a peak current of 5 A. The peak current limit protection is performed by sensing the internal high side MOSFET current and can be decreased by inserting an external resistor between CSNS pin and AGND (see [Chapter 7.10: Peak current limit on page 31](#) section for details).

This 1S8 rail is able to protect the load from Over-Voltage and Under-Voltage protection, which avoid the output to be higher than 120% or lower than 60% of the nominal value (see [Chapter 7.11.1: Output overvoltage on page 33](#) and [Chapter 7.11.2: Output under voltage on page 33](#) section for details).

When the EN\_1S8 pin goes high the VDDQ rail is turned on and the output voltage soft-start is performed by slowly charging the rail output capacitor; this behavior is achieved because

the loop voltage reference is increased linearly from zero up to 0.8V in a long time (up to a couple of milliseconds) (see [Chapter 7.6: Outputs soft-start on page 28](#) for details).

When the EN\_1S8 pin goes low, the VDDQ rail output capacitor is discharged through internal discharge MOSFET and, at the end of the capacitor discharge, the low side power MOSFET is eventually closed (see [Chapter 7.7: Outputs soft-end on page 29](#) for details).

The Power Good signal (PG\_1S8 pin) is an open drain output, shorting the output to GND in the following conditions:

- When the 1.8 V rail output voltage is outside +/- 10% range from nominal value
- When a protection (UV, OV, thermal) has been triggered
- When the regulator is in soft-start.

When VDDQ and VTT rails are enabled, PG\_1S8 is left floating and, as a consequence, pulled-up by the external pull-up resistor, if both the rails are inside +/- 10% range of nominal value. The PG\_1S8 pin can sink current up to 4 mA when it's asserted low.

### 7.1.2 VTT LDO and VTTREF buffered reference

The PM6641 provides the required DDR2/3 reference voltage on VTTREF pin. The internal buffer tracks half the voltage on VOUT\_1S8 pin and has a sink and source capability up to 15 mA with an accuracy of  $\pm 2\%$  referred to the VDDQ half.

Higher currents rapidly deteriorate the output accuracy. A 10 nF to 100 nF (33 nF typical) bypass capacitor to SGND is required for stability.

The VTT low-drop-out linear regulator has been designed to sink and source up to 2 A peak current and 1 A continuously. The VTT voltage tracks VTTREF within  $\pm 35$  mV. A remote voltage sensing pin (VTTFB) is provided to recovery voltage drops due to parasitic resistance. In DDR2/3 applications, the linear regulator input LDOIN is typically connected to VDDQ output; connecting LDOIN pin to a lower voltage (if available in the system) reduces the power dissipation of the LDO, but a minimum drop-out voltage must be guaranteed, depending on the maximum current expected.

A minimum output capacitance of 20  $\mu$ F (2x10  $\mu$ F or single 22  $\mu$ F ceramic capacitors) is enough to assure stability and fast load transient response.

According to DDR2/3 JEDEC specifications, when the system enters the suspend-to-RAM state (S5 high and S3 low) the LDO output is left in high-impedance while VTTREF and VDDQ are still alive. When the suspend-to-disk state (S3 and S5 tied to ground) is entered, all outputs are actively discharged by a tracking or a non-tracking discharge as selected through the DSCG pin (see [Chapter 7.7: Outputs soft-end on page 29](#) for details).

### 7.1.3 VTT and VTTREF soft-start

Soft-start on VTT and VTTREF outputs is achieved by current clamping. The LDO linear regulator is provided of a current fold-back protection: when the output voltage exits the internal  $\pm 10\%$  VTT-Good window, the output current is clamped at  $\pm 1$  A. Re-entering VTT-Good window releases the current limit clamping. The fold-back mechanism naturally implements a two steps soft-start charging the output capacitors with a 1 A constant current.

Something similar occurs at VTTREF pin, where the output capacitor is smoothly charged at a fixed 40 mA (typ) current limit.

### 7.1.4 S3 and S5 power management pins

According to DDR2/3 memories supply requirements, the PM6641 can manage all S0 to S5 system states just connecting EN\_VTT – EN\_1S8 pins to their respective sleep-mode signals in the notebook's motherboard: connect EN\_1S8 to S5 and EN\_VTT to S3.

Keeping EN\_VTT and EN\_1S8 high, the S0 (full-on) state is decoded and the outputs are alive.

In S3 state (EN\_1S8 = 1, EN\_VTT = 0), the PM6641 maintains VDDQ and VTTREF outputs active and VTT output in high-impedance as needed.

In S4/S5 states (EN\_1S8 = EN\_VTT = 0) all outputs are turned off and, according to DSCG pin voltage, the proper Soft-End is performed (see [Chapter 7.7: Outputs soft-end on page 29](#) section for details).

The following table resumes the DDR power supply states.

**Table 8. S3 and S5 sleep-states decoding**

S3 (EN_VTT)	S5 (EN_1S8)	System state	VDDQ	VTTREF	VTT
1	1	S0 (Full-on)	On	On	On
0	1	S3 (Suspend-to-RAM)	On	On	Hi-Z
0	0	S4/S5 (Suspend-to-disk)	Off (Discharge)	Off (Discharge)	Off (Discharge)

## 7.2 Chipset supply

The chipset power supply section is based on two constant frequency current-mode buck regulators with a pre-fixed output voltage of 1.5 V and 1.05 V.

These two independent rails have programmable switching frequency, set by inserting an external resistor between SET\_SWF pin and AGND. The PM6641 allows also to manage the switching regulators phases for 1.5 V, 1.05 V and 1.8 V (VDDQ) rails in order to limit the RMS input current (see [Chapter 7.8: Switching frequency selection on page 29](#) and [Chapter 7.9: Phase management on page 30](#) section for details).

The output voltages can easily be set to the pre-fixed value by connecting the feedback pins VFB\_1S5 and VFB\_1S05 directly to the respective output rail, avoiding the use of external components. However, if a different output voltage is desired, the feedback pins can be independently connected to the central tap of a resistor divider.

The output voltage can be adjusted from 0.8 V up to the input voltage value, decreased by a drop due to the high-side MOSFET on resistance.

(see [Chapter 7.5: Output voltage divider on page 27](#) section for details).

Both regulators are current-mode step-down switching regulators whose control loop needs to be compensated by inserting a resistor-capacitor series connected between the compensation pin (COMP\_1S5 and COMP\_1S05) and ground; if electrolytic capacitor with relevant equivalent series resistance (ESR) are used, an additional capacitor between this compensation pin and ground can be useful (see [Chapter 7.3: SW regulators control loop on page 24](#) section for details). The classical slope compensation, which allows the peak

current mode loop to avoid sub-harmonic instability with duty cycle greater than 50%, is internally implemented and no further external components are required.

The chipset supply is able to source the following average and peak currents, assuming 1 A peak-to-peak inductor current ripple:

**Table 9. Chipset supply currents**

Chipset supply rail [V]	Average current [A]	Peak current [A]
1.5	1.5	3.0
1.05	2.1	4.0

The peak current and the inductor ripple must be carefully evaluated in order to choose the right current limit protection; this feature is performed by sensing the internal high side MOSFET current and can be decreased by inserting an external resistor between CSNS pin and AGND (see [Chapter 7.10: Peak current limit on page 31](#) for details).

Both rails are able to protect the load from over-voltage and under-voltage protection, which avoid the output to be higher than 120% or lower than 60% of the nominal value (see [Chapter 7.11.1: Output overvoltage on page 33](#) and [Chapter 7.11.2: Output under voltage on page 33](#) section for details).

When the EN\_1S5 or EN\_1S05 pin goes high the respective rail is turned on and the output voltage soft-start is performed by slowly charging the rail output capacitor; this behavior is achieved because the loop voltage reference is increased linearly from zero up to 0.8V (see [Chapter 7.6: Outputs soft-start on page 28](#) section for details). When the EN\_1S5 or EN\_1S05 pin goes low, the respective rail output capacitor is discharged through internal discharge MOSFET and, at the end of the capacitor discharge, the low side power MOSFET is finally closed (see [Chapter 7.7: Outputs soft-end on page 29](#) section for details).

Each rail has a dedicated pin to assert if its output voltage is not in the power good window, i.e. if the output voltage drops 10% below or rises 10% above the nominal regulated value. These power good signals (PG\_1S5 and PG\_1S05 pins) are open drain outputs, tied to GND in the following conditions:

- When the rail output voltage is outside +/- 10% range from nominal value
- When a protection (UV, OV, thermal) has been triggered
- When the regulator is in soft-start.

The PG\_1S5 and PG\_1S05 pins can sink current up to 4 mA when it's asserted low.

### 7.3 SW regulators control loop

The PM6641 switching regulators are buck converters employing a constant frequency, peak current mode PWM control loop, as shown in the following figure:

**Figure 28. SW regulator control loop**

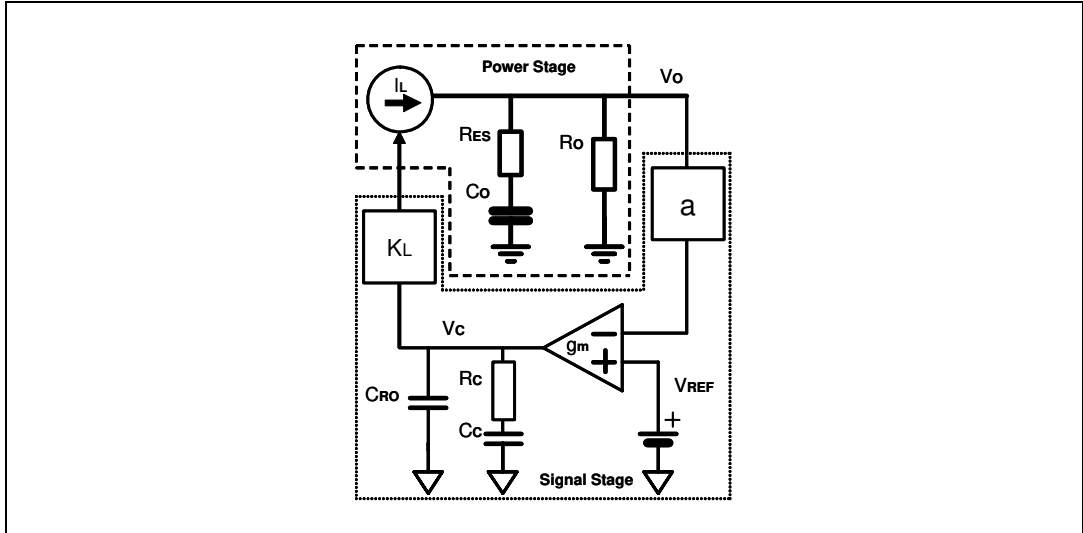

In the current mode constant frequency loop the power stage is represented by a controlled current generator feeding the power stage output capacitor and load. The equivalent transfer function is:

**Equation 1**

$$H(s) = \frac{V_O(s)}{I_L(s)} = \frac{(sC_O R_{ES} + 1)}{sC_O (R_{ES} + R_O) + 1} R_O$$

with  $C_o$  and  $R_{es}$  being the output capacitance and its equivalent series resistance and  $R_o$  representing the output load.



In order to obtain the typical integrative loop transfer function the signal stage must compensate for the power stage pole (due to the output capacitor and the load) and zero (above the loop bandwidth if ceramic output capacitors are selected). The signal stage transfer function is:

### Equation 2

$$G(s) = g_m K_L \alpha \frac{s C_C R_C + 1}{s C_C \left( s C_{R_O} R_C + \frac{C_{R_O}}{C_C} + 1 \right)}$$

Where  $g_M$  is the power stage transconductance,  $K_L$  is a design parameter and  $\alpha$  is the gain due to the output resistor divider ( $0.8 \text{ V} / V_{out}$ ). The external compensation network ( $R_C$ ,  $C_C$  and  $C_{R_O}$ ) introduces:

- One zero, to compensate the power stage pole:
 
$$C_C R_C = C_O (R_O + R_{ES})$$
- One pole in order to delete the static output voltage error;
- One pole, if necessary, in order to compensate the high frequency zero due to the output capacitor ESR:

$$C_{R_O} R_C = C_O R_{ES}$$

The control loop gain is obtained by multiplying  $G(s)$  by  $H(s)$ :

### Equation 3

$$G_{LOOP}(s) = g_m K_L \alpha \frac{(s C_C R_C + 1)}{s C_C \left( s C_{R_O} R_C + \frac{C_{R_O}}{C_C} + 1 \right)} \cdot \frac{(s C_O R_{ES} + 1)}{s C_O (R_{ES} + R_O) + 1} R_O$$

This model provides good results if the control loop cut-off frequency  $f_{CO}$  is lower than about  $f_{sw}/10$ .

### 7.4 SW regulators pulse skipping and PWM mode

In order to enhance the light load efficiency each switching regulator enters the pulse skipping algorithm when the output current sourced is too low. The threshold load current which allows the regulator to enter the pulse skipping mode can be estimated with the following formula:  $(V_i - V_o) / (2L f_{sw}) * V_o / V_i$

Equation 4

$$I_{omin} \approx \frac{(V_i - V_o)}{(2L f_{sw})} \cdot \frac{V_o}{V_i}$$

When the load current is lower than  $I_{Omin}$  value, the switching regulator begins to skip some cycle, decreasing the effective switching frequency and, as a consequence, reducing the switching losses. This mode of operation is guaranteed by the presence of the zero crossing current comparator, the internal block which senses the inductor current and avoids this current to becoming negative, in the normal operating condition.

The inductor current is allowed to become negative when the output voltage rises above the +10% power good threshold. In this condition of output soft over voltage the zero crossing current comparator is deactivated and the pulse skipping algorithm is replaced by the typical PWM one; as a consequence each switching regulator can sink up to some hundreds milli amps to decrease the output voltage to the nominal value.

Figure 29. SW regulators pulse skipping and PWM mode

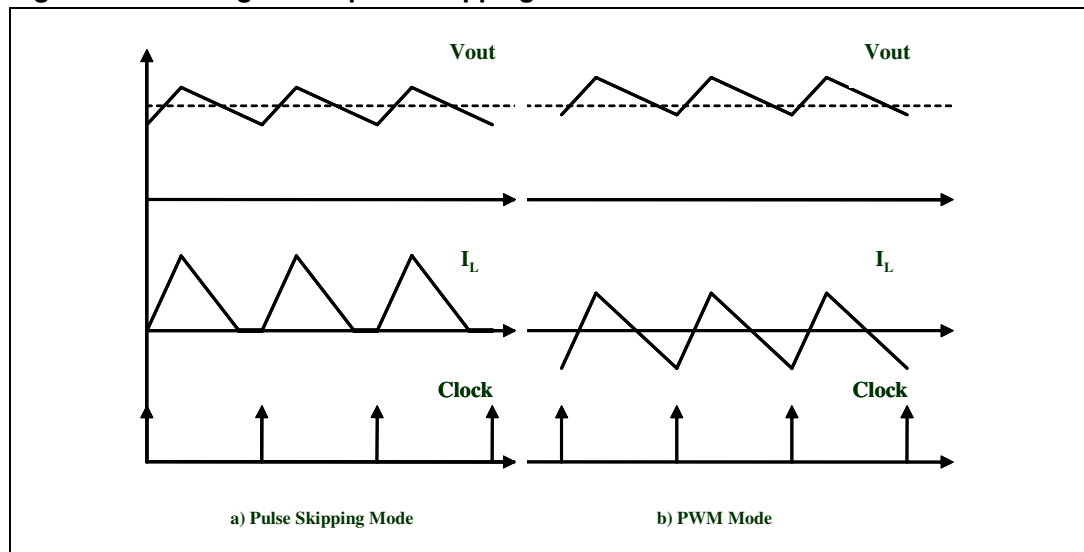

## 7.5 Output voltage divider

PM6641 switching regulators are adjustable voltage converters.

If the feedback pin (VFB\_1S8, VFB\_1S5, VFB\_1S05 respectively belonging to VDDQ (1.8 V), 1.5 V, 1.05 V rail) is directly tied to the rail output capacitor the internal divider with pre-fixed output voltage value is activated and the nominal output voltages are selected.

If the feedback pin is connected to the output voltage divider central tap (as depicted in [Figure 30](#))

**Figure 30. SW regulator with external divider**

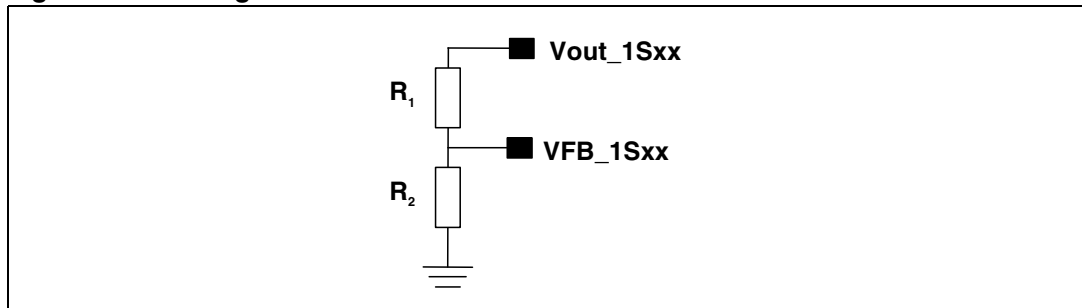

the PM6641 switching regulator automatically recognizes the external divider and the output voltage is regulated to the following value:

**Equation 5**

$$V_{out\_1Sxx} = \left( \frac{R_1}{R_2} + 1 \right) \cdot 0.8V$$

## 7.6 Outputs soft-start

The soft-start function of each switching regulator is achieved by ramping up the SS pin voltage with a constant slew rate  $dV/dt$ .

When the switching section is enabled (EN high), the SS pin constant current charges the capacitor connected between SS and ground pins.

The SS voltage is used as reference of the switching regulator and the output voltage of the converter follows the ramp of the SS voltage. When the SS pin voltage is higher than 0.8 V, the error amplifier uses the internal  $0.8\text{ V} \pm 1\%$  reference to regulate the output voltage.

**Figure 31. SW regulator programmable soft-start**

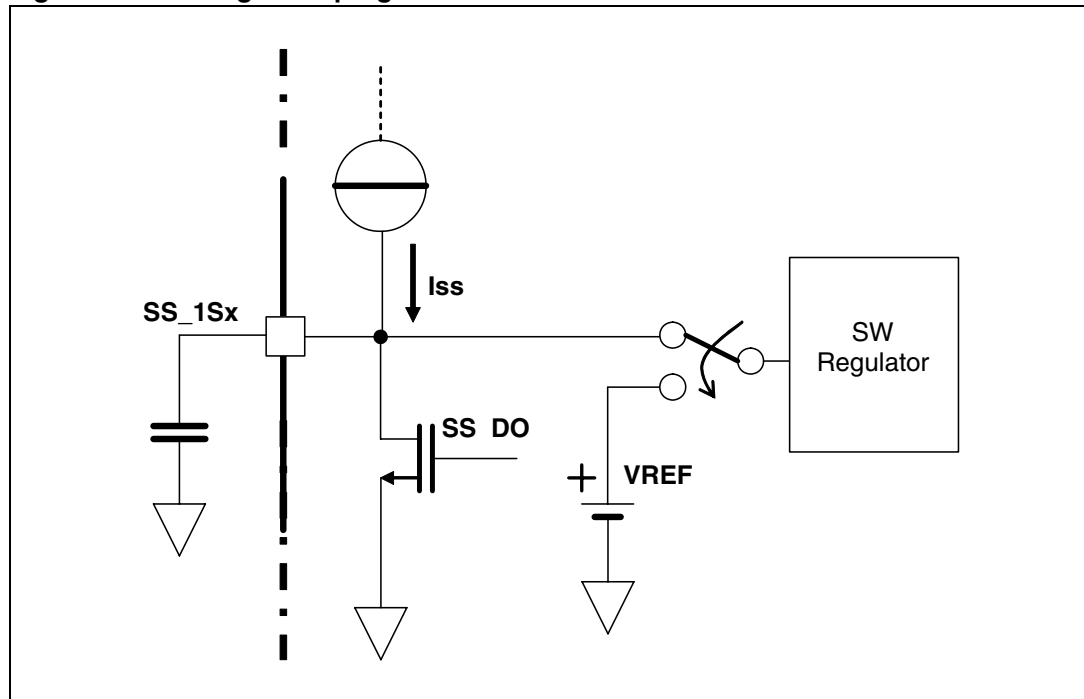

During the soft-start period the current limit is set to the nominal value.

The  $dV/dt$  slope is set by charging the external capacitor with a  $10\ \mu\text{A}$  current. The capacitance values has to be of the order of magnitude of  $10\ \text{nF}$  for a  $1\ \text{msec}$  soft-start duration, as pointed out by the following formula:

**Equation 6**

$$C = \frac{I \cdot \Delta t}{\Delta V} = \frac{10\ \mu\text{A} \cdot 1\text{ms}}{0.8\text{V}} = 12.5\text{nF}$$

During the soft-start the output under voltage management is not enabled, whereas the output over voltage, the current limit and the thermal overheat are always monitored.

When the first switching regulator is turned on the output soft-start begins after an additional delay of about  $180\ \mu\text{s}$ , due to PM6641 initializing and fuses reading.

## 7.7 Outputs soft-end

When the switching regulator enable pin (EN\_1S8 for the VDDQ section, EN\_1S5 and EN\_1S05 for chipset sections) goes down or when UV or thermal protections are detected, the switching regulator output capacitor is actively discharged through a dedicated discharge MOSFET of about 25  $\Omega$  typical resistance.

The PM6641 DDR supply allows choosing between two different output discharge behaviors, involving the VDDQ (1S8) switching rail, VTT LDO termination and VTTREF reference buffered voltage: the tracking discharge and the non-tracking discharge. This selection is set by tying the discharge pin (DSCG) to AVCC (tracking discharge enabled) or to AGND (tracking discharge disabled).

When the 1.8 V rail is turned off (EN\_1S8 goes low) and non-tracking discharge is active (DSCG is low), or when UV or thermal protections are detected, the VDDQ and VTT rails and the VTTREF buffer are discharged by internal discharge MOSFETs, through the VSW\_1S8, VTTFB and VTTREF pins respectively. VTT termination output capacitor is discharged through 25  $\Omega$  dedicated MOSFET whereas VTTREF output capacitor is discharged through 200  $\Omega$  dedicated MOSFET.

When the 1.8 V rail is turned off (EN\_1S8 goes low) and tracking discharge is selected (DSCG is high), tracking discharge takes place:

- The 1.8 V rail regulator is discharged by internal MOSFET
- The 0.9 V VTT LDO and VTTREF work in tracking with the half of 1.8 V rail

When the VTT LDO and VTTREF reach a voltage threshold of about 200-300 mV, the device switches to non-tracking discharge mode and the internal discharge MOSFETs are turned on.

## 7.8 Switching frequency selection

SET\_SWF (pin 2) allows to vary the internal oscillator switching frequency, in the range of 500 kHz  $\Leftrightarrow$  1 MHz, by connecting this pin to AGND through a resistor between 70 k $\Omega$   $\Leftrightarrow$  140k  $\Omega$ .

The following table summarizes the output resistor – switching frequency correspondence:

**Table 10. Typical values for switching frequency selection**

R <sub>SET_SWF</sub> (k $\Omega$ )	Approx. switching frequency (kHz)
140	500
100	670
70	1000

When SET\_SWF is tied to AVCC the internal reference is chosen and each regulator performs a typical 750 kHz switching frequency.

## 7.9 Phase management

When all the three switching regulators high side MOSFETs are turned on simultaneously the input root mean square (RMS) current could rise up to very high values, increasing the system losses and inducing external components overheating. It's possible to reduce the input overall RMS current by inserting one ceramic capacitor as close as possible to each switching regulator power supply input, reducing the impulsive input current path. However this synchronous mode of operation is jitter-free and noise immune.

Another possible way to reduce the input RMS current is based on the phase shifting technique, which decreases the total input current by delaying the regulators turn on pulse. With three regulators turned on, the 120d e.g. phase shifting allows to reduce the overall input current up to 1.73 times as depicted in the following configuration, in which three independent regulators with  $V_{out}/V_{in}$  lower than 0.333 and identical output current ( $I$ ) are managed with synchronous or 120 deg phase shifted turning on.

**Figure 32. SW regulator phase management**

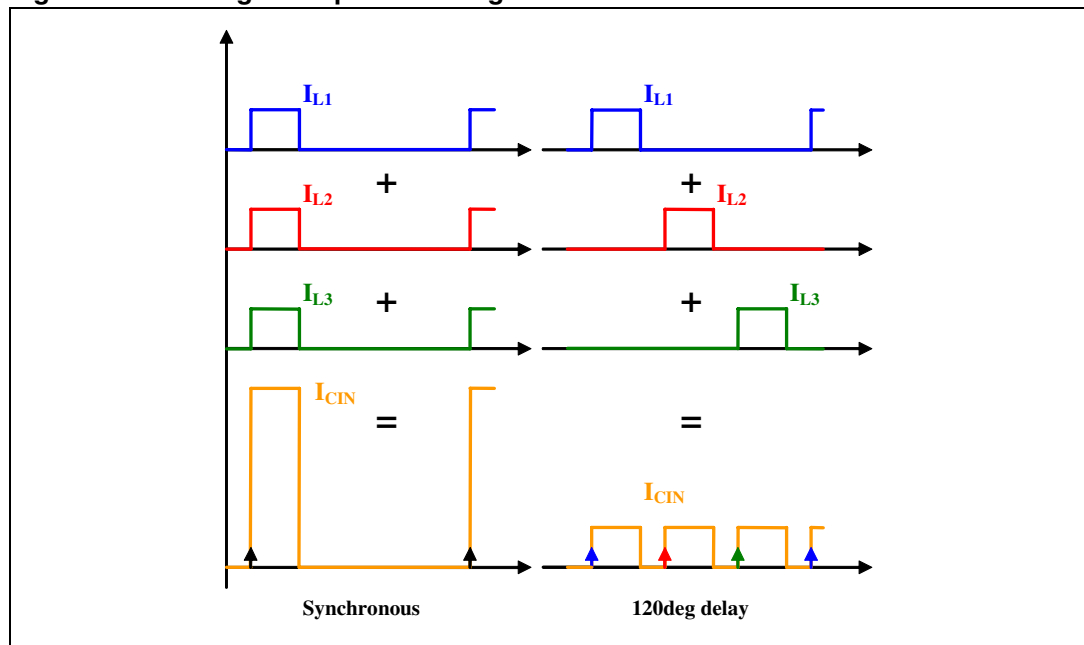

Each regulator RMS input current is easily computed:

**Equation 7**

$$I_{L1,L2,L3} = \sqrt{\frac{1}{T_{SW}} \int_{T_{SW}} I_{L1,L2,L3}^2 dt} = \sqrt{\frac{1}{T_{SW}} I^2 T_{ON}}$$

defining  $T_{SW}$  the switching period, equal to  $1/f_{sw}$  and  $T_{ON}$  the high side MOSFET on time.

The synchronous mode of operation provides the following total input current:

**Equation 8**

$$I_{\text{CIN,SYNC}} = \sqrt{\frac{1}{T_{\text{SW}}} \int_{T_{\text{SW}}} (I_{\text{L1}} + I_{\text{L2}} + I_{\text{L3}})^2 dt} = \sqrt{\frac{1}{T_{\text{SW}}} (3I)^2 T_{\text{ON}}}$$

whereas by shifting the three regulator turn on pulses of 120 deg the resulting total input current is given by

**Equation 9**

$$I_{\text{CIN,DELAY}} = \sqrt{\frac{1}{T_{\text{SW}}} \int_{T_{\text{SW}}} (I_{\text{L1}} + I_{\text{L2}} + I_{\text{L3}})^2 dt} = \sqrt{\frac{1}{T_{\text{SW}}} (I^2 + I^2 + I^2) T_{\text{ON}}}$$

that is  $\sqrt{3} \cong 1.73$  times smaller than the one computed before.

The PM6641 SET\_PH1 pin, if tied to AVCC, enables the synchronous switching regulators high side MOSFET turn on, whereas if tied to ground enables the 120 deg phase shifting.

## 7.10 Peak current limit

The peak current limit performed by the PM6641 switching regulators allows to monitor, cycle by cycle, the inductor current; this feature prevents IC wire bonding overheating and failure.

If the current sensed on the monolithic high side MOSFET reaches the programmed current limit the regulator starts behaving like a current generator, more than a voltage regulator. Consequently, if the output load still increases the rail output capacitor discharges itself and the regulator works as current generator until the output under voltage occurs and the regulator is latched off (see [Chapter 7.11.2: Output under voltage on page 33](#) section for details).

The pin 4 (CSNS) allows to select the right value for the peak current limit by inserting an external resistor ( $R_{\text{CSNS}}$ ) between this pin and ground. CSNS forces a constant voltage on RCSNS resistor or, when tied to AVCC, enables the internal reference (equal to a 50 kΩ external resistor). A simple equation shows how to compute the right value for  $R_{\text{CSNS}}$  in order to decrease the peak current limit:

**Equation 10**

$$R_{\text{CSNS}} = \alpha \cdot \frac{V_{\text{REF}}}{I_{\text{CL}}}$$

where  $V_{REF} = 0.9V$  is the constant voltage forced by CSNS pin,  $R_{CSNS} [\Omega]$  is the resistor connected between CSNS and AGND,  $\alpha$  is the coefficient that collects the MOS current sensing scaling factor and other design parameters and  $I_{CL}$  is the peak current limit [A].

The following table resumes values for all the switching regulators.

**Table 11. Typical SW regulators values**

SW regulator	$\alpha$
1.8V	333x10e3
1.5V	222x10e3
1.05V	278x10e3

The following graph is a plot of the switching regulators peak current limit, increasing the  $R_{CSNS}$  resistor:

**Figure 33. SW regulators peak current limit**

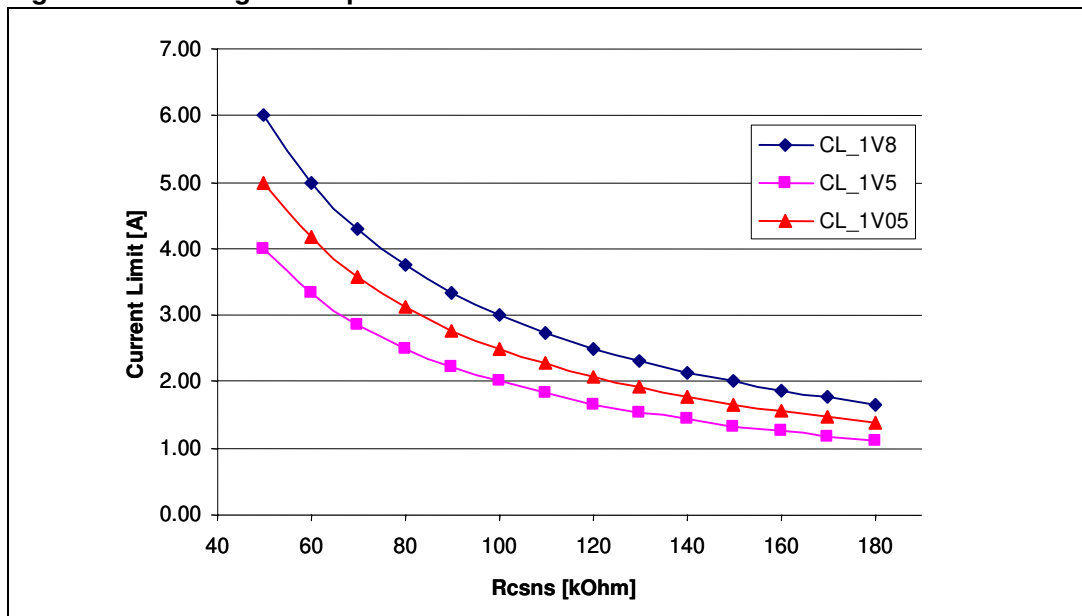

From the previous plot and table it's clear that the three regulators peak current limits are scaled; by changing the  $R_{CSNS}$  external resistor the three peak current limits all change.



## 7.11 Fault management

PM6641 has been conceived to constantly monitor the rails output voltage. In order to protect itself from failure and the load from damage, the device is able to:

- Limit the power MOSFETs current
- Detect output overvoltage
- Detect output under voltage
- Monitor the device temperature
- Detect input power supply under voltage

The current limit is an auto-recovery protection, monitoring cycle by cycle the regulators high side MOSFET current (see [Chapter 7.10: Peak current limit on page 31](#) section for details).

The output over voltage and under voltage and the input under voltage are latched protections, whereas the thermal shutdown is auto-recovery; all these features are described in the following sections.

### 7.11.1 Output overvoltage

If the output voltage of a switching regulator (memory supply rail VDDQ (1.8 V), chipset supply rails 1.5 V or 1.05 V) becomes greater than 120% of its nominal value, an over voltage (OV) protection for that rail is triggered. As a consequence the regulator stops switching, the internal low-side power MOSFET of that rail is turned on and the high-side MOSFET is turned off. The OV protection effect is the very quick discharge of the rail output capacitor.

The OV condition is latched, and it can be reset only by toggling the enable pin of that rail or by turning off and on the IC power supply (AVCC pin).

An OV condition for one of the outputs of the PM6641 has no effect on the operation of the other outputs (e.g., if the OV protection is triggered for the VDDQ regulator, the 1.5 V and 1.05 V regulators continue to work normally).

### 7.11.2 Output under voltage

If the output voltage of a switching regulator (memory supply rail VDDQ (1.8 V), chipset supply rails 1.5 V or 1.05 V) becomes lower than 60% of its nominal value (e.g. because the rail was shorted to ground or the output load is increased dramatically), an under voltage (UV) protection for that rail is triggered.

An UV condition causes the soft-end of the rail, which implies the regulator turn off and the rail discharge MOSFET turn on (see [Chapter 7.7: Outputs soft-end on page 29](#) section for details); the UV condition is latched, and it can be reset only by toggling the enable pin of that rail or by turning off and on the PM6641 power supply (AVCC pin).

As for OV protection, each switching regulator can perform under voltage protection without affecting other regulators.

The over-current feature is implemented in the PM6641 by limiting the output current of each rail (see [Chapter 7.10: Peak current limit on page 31](#) section for details) and triggering a latched UV protection if the output voltage falls because of a load requesting more current than the limit.

### 7.11.3 Thermal shutdown

If the device temperature exceeds 150 °C, a thermal protection is triggered. As a consequence, the output soft end takes place for all the outputs of the PM6641 (VDDQ rail (1.8 V), VTT, VTTREF, 1.5 V, 1.05 V) by closing the output discharge MOSFET (see [Chapter 7.7: Outputs soft-end on page 29](#) section for details).

The thermal protection condition is not latched: the device leaves this condition and reactivates itself automatically when its temperature falls below 135 °C (i.e. there is a 15 °C of hysteresis).

### 7.11.4 Input under voltage lock-out

The PM6641 AVCC pin is the device power supply input. This pin must be fed with 5 V,  $\pm 10\%$  in order to allow the device to work properly. If this rail falls under 3.9 V typical threshold, the input under voltage is detected and the device performs the under voltage lock-out (UVLO) protection. When this event occurs, each regulator stops switching and the following actions are performed:

- The memory supply rails (VDDQ, VTT and VTTREF) are discharged by closing the output discharge MOSFET (see [Chapter 7.7: Outputs soft-end on page 29](#) section for details);
- Chipset power supply output rails (1V5 and 1V05 rails) are discharged through the low side power MOSFETs;
- The device is turned OFF.

The PM6641 is turned on again when the AVCC pin voltage reaches the UVLO on threshold (about 4.1 V).

## 8 Components selection

The PM6641 switching regulator sections are buck converters employing a constant frequency, current mode PWM current loop (see [Chapter 7.3: SW regulators control loop on page 24](#) section for details).

The duty-cycle of the buck converter is, in steady-state conditions, given by

### Equation 11

$$D = \frac{V_{OUT}}{V_{IN}}$$

The switching frequency directly affects two parameters:

- Inductor size: greater frequencies mean smaller inductances. In notebook applications, real estate solutions (i.e. low-profile power inductors) are mandatory also with high saturation and root mean square (RMS) currents.
- Efficiency: switching losses are proportional to the frequency. Generally, higher frequencies imply lower efficiency.

### 8.1 Inductor selection

Once the switching frequency has been defined, the inductance value depends on the desired inductor current ripple. Low inductance value means great ripple current that brings to poor efficiency and great output noise. On the other hand a great current ripple is desirable for fast transient response when a load step is applied.

Otherwise, great inductance brings to good efficiency but the load transient response is critical, especially if  $V_{INmin} - V_{OUT}$  is little. The product of the output capacitor's ESR multiplied by the inductor ripple current must be taken in consideration; the PM6641 switching regulators current loop doesn't need a minimum output ripple in order to work properly, so a ceramic output capacitor can be considered a good choice.

A good trade-off between the transient response time, the efficiency, the cost and the size is choosing the inductance value in order to maintain the inductor ripple current between 20% and 50% (usually 30%) of the maximum output current.

The maximum inductor current ripple,  $\Delta I_{L,MAX}$ , occurs at the maximum input voltage.

With these considerations, the inductance value can be calculated with the following expression:

### Equation 12

$$L = \frac{V_{IN} - V_{OUT}}{f_{SW} \cdot \Delta I_L} \cdot \frac{V_{OUT}}{V_{IN}}$$

where  $f_{SW}$  is the switching frequency,  $V_{IN}$  is the input voltage,  $V_{OUT}$  is the output voltage and  $\Delta I_L$  is the inductor current ripple.

Once the inductor value is determined, the inductor current ripple is then recalculated:

**Equation 13**

$$\Delta I_{L,MAX} = \frac{V_{IN,MAX} - V_{OUT}}{f_{SW} \cdot L} \cdot \frac{V_{OUT}}{V_{IN,MAX}}$$

The next step is the computation of the maximum RMS inductor current:

**Equation 14**

$$I_{L,RMS} = \sqrt{(I_{LOAD,MAX})^2 + \frac{(\Delta I_{L,MAX})^2}{12}}$$

The inductor must have an RMS current greater than  $I_{L,RMS}$  in order to assure thermal stability.

Then the calculation of the maximum inductor peak current follows:

**Equation 15**

$$I_{L,PEAK} = I_{LOAD,MAX} + \frac{\Delta I_{L,MAX}}{2}$$

$I_{L,PEAK}$  is important when choosing the inductor, in term of its saturation current.

The saturation current of the inductor should be greater than the maximum between  $I_{L,peak}$  and the programmed peak current limit, selected by an external resistor connected between CSNS pin and AGND (as described in *current limit* section).

## 8.2 Input capacitor selection

In a buck topology converter the current that flows through the input capacitor is pulsed and with zero average value. The RMS input current, for each switching regulator, can be calculated as follows:

**Equation 16**

$$I_{CinRMS} = \sqrt{I_{LOAD}^2 \cdot D \cdot (1-D) + \frac{1}{12} D \cdot (\Delta I_L)^2}$$

Neglecting the second term, the equation is reduced to:

**Equation 17**

$$I_{CinRMS} \cong I_{LOAD} \sqrt{D \cdot (1-D)}$$

The losses due to the input capacitor are thus maximized when the duty-cycle is 0.5:

**Equation 18**

$$P_{\text{loss}} = \text{ESR}_{\text{Cin}} \cdot I_{\text{CinRMS,MAX}}^2 = \text{ESR}_{\text{Cin}} \cdot (0.5 \cdot I_{\text{LOAD,MAX}})^2$$

The input capacitor should be selected with a RMS rated current higher than  $I_{\text{CinRMS,MAX}}$ .

Tantalum capacitors are good in term of low ESR and small size, but they occasionally can burn out if subjected to very high current during operation. Multi-Layers-Ceramic-Capacitors (MLCC) have usually a higher RMS current rating with smaller size and very low ESR.

When only one common input capacitor is chosen for the application, instead of one dedicated capacitor for each regulator (close to each input power supply pins), the total input current can be quite different from the arithmetic sum of the buck regulators RMS input currents, if phase management is allowed (see [Chapter 7.9: Phase management on page 30](#) section for details).

### 8.3 Output capacitor selection

Using tantalum or electrolytic capacitors, the selection is made referring to ESR and voltage rating rather than by a specific capacitance value.

The output capacitor has to satisfy the output voltage ripple requirements. At a given switching frequency, small inductor values are useful to reduce the size of the choke but increase the inductor current ripple. Thus, to reduce the output voltage ripple a low ESR capacitor is required:

**Equation 19**

$$\text{ESR} \leq \frac{V_{\text{RIPPLE,MAX}}}{\Delta I_{\text{L,MAX}}}$$

where  $V_{\text{RIPPLE}}$  is the maximum tolerable ripple voltage.

The zero introduced by the output capacitor ESR must be higher than the switching frequency or must be compensated (see [Chapter 7.3: SW regulators control loop on page 24](#) section for details):

**Equation 20**

$$f_{\text{SW}} > f_z = \frac{1}{2\pi \cdot \text{ESR} \cdot C_{\text{OUT}}}$$

In order to minimize the output voltage ripple, ceramic capacitors are suggested.

If ceramic capacitors are used, the output voltage ripple due to inductor current ripple is negligible. Then the inductance could be smaller, reducing the size of the choke. In this case it is important that output capacitor can adsorb the inductor energy without generating an overvoltage condition when the system changes from a full load to a no load condition.

The minimum output capacitance can be chosen by the following equation:

**Equation 21**

$$C_{OUT,min} = \frac{L \cdot I_{LOAD,MAX}^2}{V_f^2 - V_i^2}$$

where  $V_f$  is the output capacitor voltage after the load transient and  $V_i$  is the output capacitor voltage before the load transient.

## 8.4 SW regulator compensation components selection

As described in section *SW regulators control loop*, the PM6641 switching regulators control loop is:

**Equation 22**

$$G_{LOOP}(s) = g_m K_L \alpha \frac{(s C_C R_C + 1)}{s C_C \left( s C_{R_0} R_C + \frac{C_{R_0}}{C_C} + 1 \right)} \cdot \frac{(s C_O R_{ES} + 1)}{s C_O (R_{ES} + R_O) + 1} R_O$$

If the output capacitor  $C_O$  and its equivalent series resistance (ESR)  $R_{ES}$  provide a low frequency zero,  $f_{z_0} = \frac{1}{2\pi C_O R_{ES}}$ , the roll-off compensation pole must be added:

**Equation 23**

$$f_{PRO} \cong \frac{1}{2\pi C_{R_0} R_C}$$

This pole is useful if the  $f_{z_0}$  zero is greater than about  $f_{C_0}/5$ .

However, the first assumption must relate the cross-over frequency,  $f_{CO}$ , with the control loop gain:

**Equation 24**

$$|G_{LOOP}(j2\pi f_{CO})| \cong g_m K_L \alpha \frac{2\pi f_{CO} C_C R_C}{2\pi f_{CO} C_C \cdot 2\pi f_{CO} C_O (R_{ES} + R_O)} R_O = g_m K_L \alpha \frac{R_C R_O}{2\pi f_{CO} C_O (R_{ES} + R_O)}$$

From the definition of cross-over frequency, the value of the compensation resistor is derived:

**Equation 25**

$$|G_{\text{LOOP}}(j2\pi f_{\text{CO}})| = 1 \Rightarrow R_{\text{C}} = \frac{2\pi f_{\text{CO}} C_{\text{O}} (R_{\text{ES}} + R_{\text{O}})}{g_{\text{m}} K_{\text{L}} \alpha R_{\text{O}}}$$

A good choice for the cross-over frequency is to assign  $f_{\text{CO}}$  equal to  $f_{\text{sw}}/10$ .

The fixed parameters  $g_{\text{m}} = 300 \mu\text{s}$  and  $K_{\text{L}} = 4.4 \text{ s}$  are design parameters, whereas the feedback divider factor ( $\alpha$ ) is application dependant (see [Chapter 7.3: SW regulators control loop on page 24](#) section for details).

After computing  $R_{\text{C}}$ , the compensation capacitor can be designed in order to place the compensation zero near the power stage pole:

**Equation 26**

$$C_{\text{C}} = \frac{C_{\text{O}} (R_{\text{O}} + R_{\text{ES}})}{R_{\text{C}}}$$

The roll-off capacitance, as said previously, must compensate for the power stage high frequency zero, when necessary:

**Equation 27**

$$C_{\text{RO}} = \frac{C_{\text{O}} R_{\text{ES}}}{R_{\text{C}}}$$

As final step, it's important to verify that the compensation zero is quite far from the cross-over frequency. An empirical rule is satisfied if the following holds:

**Equation 28**

$$f_{\text{ZC}} = \frac{1}{2\pi C_{\text{C}} R_{\text{C}}} \leq \frac{f_{\text{CO}}}{5}$$

All these considerations are true if the cross-over frequency is quite lower than the switching frequency, and the compensation zero and the power stage pole are far enough from  $f_{\text{CO}}$ .

## 8.5 Layout guidelines

Each signal is referred to AGND, the analog ground. In a typical 4-layers PCB one internal layer should be dedicated to this common ground. The IC thermal pad must be connected to AGND plane through multiple VIAs, in order to remove the IC heat and to obtain the best performance. Furthermore, each switching regulator has a dedicated power ground (SGND\_1Sxx); all these SGNDs must be star-connected, in a single point, with AGND.

For each switching section the power components (inductor and input/output capacitors) must be placed near the VSW\_1Sxx, VIN\_1Sxx and SGND\_1Sxx pins and connected with large (at least 20 mils or larger) and short PCB traces, in order to limit the path of the current high frequency components and, consequently, to reduce the injected noise. If the power components routing involves more than one layer, as many VIAs as possible must be inserted to reduce the series resistance and improve the global efficiency.

The VTT external components (input and output capacitors) must be placed near the LDO regulator input (LDOIN) and output (VTT) pins, and must be routed with large and short traces, in order to limit the parasitic series resistance.

The feedback pins (VFB\_1Sxx and VTTFB) must reach the feedback points through dedicated PCB traces, typically 10 mils width; larger feedback traces are not required.

For reference layout, refer to *PM6641 demonstration kit* document.



## 9 Application examples

The following application examples are typical or customized applications. Each example has been tested and evaluated and the schematic and BOM are available for reference design.

### 9.1 UMPC DDR2 and chipset power supply

Figure 34. System architecture for DDR2 and chipset power supply

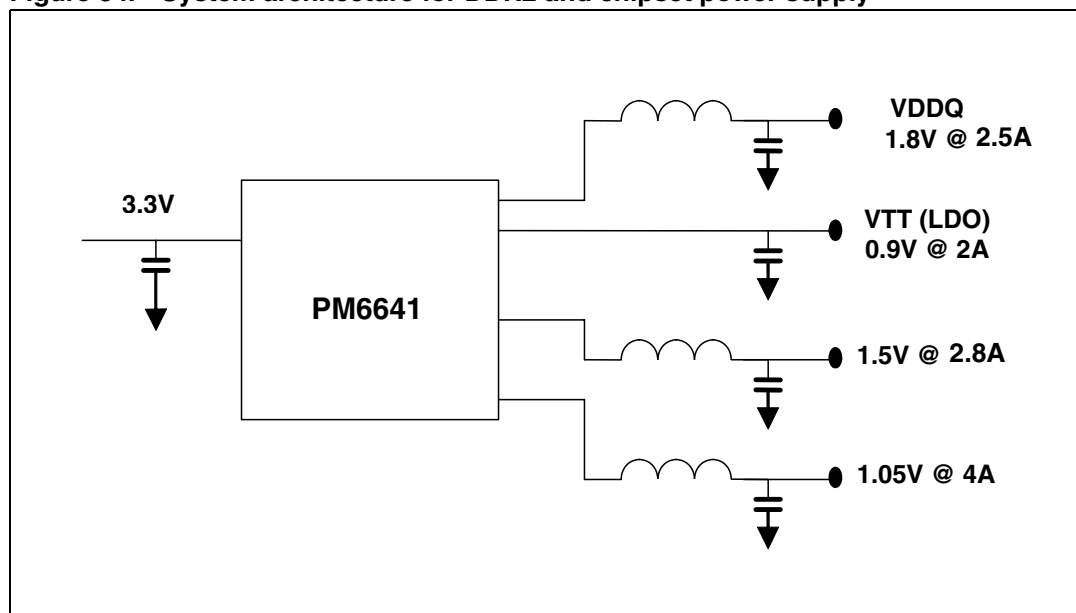

This application is conceived for real estate constrained portable equipment with DDR2 memory. An input power voltage pre-regulated to 3.3 V or 5 V is available and the available output maximum power levels are shown in [Figure 34](#). The switching regulator average load is estimated to be about 50% of the maximum load; this upper limit must be respected in order to avoid dangerous stresses for internal power MOSFETs. The following table resumes these current values.

Table 12. Expected average and peak currents for DDR2 and chipset power supply

Output rail	Max non continuous load [A]	Expected average load [A]
1.8 V (VDDQ)	2.5	1.3
0.9 V (VTT)	±2	0.3
1.5 V	2.8	1.4
1.05 V	4	2

The default switching frequency has been selected (750 kHz) and the tracking discharge has been enabled in agreement with DDR2 JEDEC specifications. No external resistor dividers are required for these output voltage levels. The allowed inductor current ripple is about 35% of the expected peak load.

The power and signal components have been selected in agreement with [Chapter 8 on page 35](#) equations.

The following schematic and bill of materials (BOM) are for reference design.

**Figure 35. Suggested schematic for DDR2 and chipset power supply**

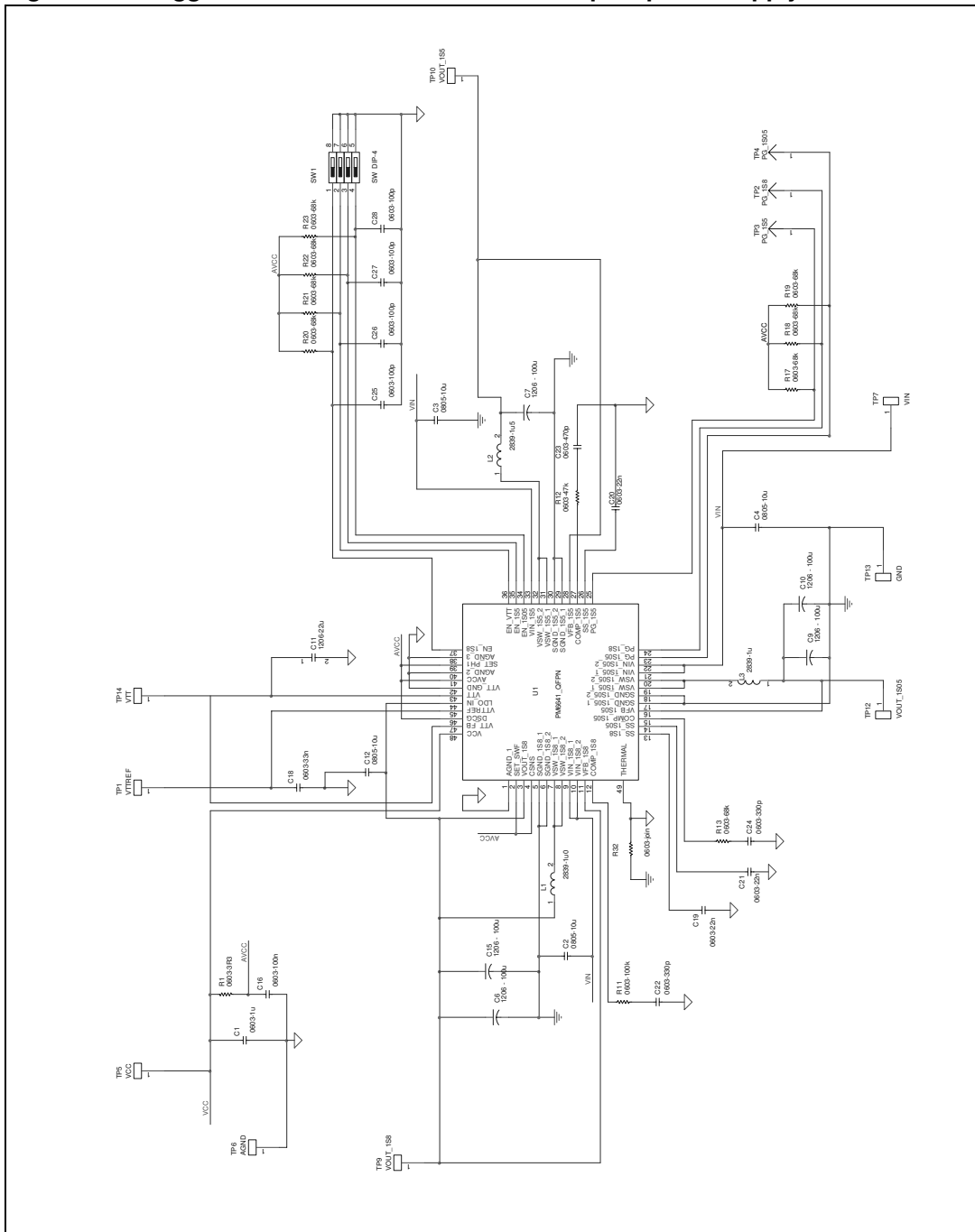

Table 13. BOM suggested components for DDR2 and chipset power supply

Qty	Component	Description	Package	Part number	MFR	Value
1	C1	Ceramic, 10 V, X5R, 10%	SMD 0603		Standard	1 $\mu$ F
4	C2, C3, C4, C12	Ceramic, 10 V, X5R, 10%	SMD 0805	GRM21BR61A106KE19	Murata	10 $\mu$ F
5	C6, C7, C9, C10, C15	Ceramic, 4 V, X5R, 20%	SMD 1206	AMK316BJ107ML	Taiyo Yuden	100 $\mu$ F
1	C11	Ceramic, 6.3 V, X5R, 10%	SMD 1206	GRM31CR60J226KE19	Murata	22 $\mu$ F
1	C16	Ceramic, 16 V, X7R, 10%	SMD 0603		Standard	100 nF
1	C18	Ceramic, 25 V, X7R, 10%	SMD 0603	GRM188R71E333KA01	Murata	33 nF
3	C19, C20, C21		SMD 0603		Standard	22 nF
2	C22, C24	Ceramic, 50 V, C0G, 5%	SMD 0603		Standard	330 pF
1	C23	Ceramic, 50 V, C0G, 5%	SMD 0603		Standard	470 pF
4	C25, C26, C27, C28	Ceramic, 50 V, C0G, 5%	SMD 0603		Standard	100 pF
1	R1	Chip resistor, 0.1 W, 1%	SMD 0603		Standard	3R3
1	R11	Chip resistor, 0.1 W, 1%	SMD 0603		Standard	100 k $\Omega$
1	R12	Chip resistor, 0.1 W, 1%	SMD 0603		Standard	47 k $\Omega$
8	R13, R17, R18, R19, R20, R21, R22, R23	Chip resistor, 0.1 W, 1%	SMD 0603		Standard	68 k $\Omega$
1	R32	Chip resistor, 0.1 W, 1%	SMD 0603		Standard	0 $\Omega$
2	L1, L3	SMT 11 Arms, 9.5 m $\Omega$	SMD 2827	744312100 /LF	Würth	1.0 $\mu$
1	L2	SMT 9 Arms, 10.5 m $\Omega$	SMD 2827	744312150 /LF	Würth	1.5 $\mu$
1	U1	IC VR - 48 PIN	VFQFPN 7x7	PM6641	ST	PM6641

Note: This applicative solution has been tested and the PM6641 EVAL demonstration board is now available for demonstration.

Please refer also to PM6641 demonstration kit document for test and measurement results.

## 10 Package mechanical data

In order to meet environmental requirements, ST offers these devices in different grades of ECOPACK® packages, depending on their level of environmental compliance. ECOPACK® specifications, grade definitions and product status are available at: [www.st.com](http://www.st.com). ECOPACK® is an ST trademark.

**Table 14. VFQFPN-48 (7x7x1.0 mm) package mechanical data**

Dim.	mm		
	Min.	Typ.	Max.
A	0.80	0.90	1.00
A1		0.02	0.05
A2		0.65	1.00
A3		0.25	
b	0.18	0.23	0.30
D	6.85	7.00	7.15
D2	2.25	4.70	5.25
E	6.85	7.00	7.15
E2	2.25	4.70	5.25
e	0.45	0.50	0.55
L	0.30	0.40	0.50
ddd			0.08

Figure 36. VFQFPN-48 (7x7x1.0 mm) package drawings

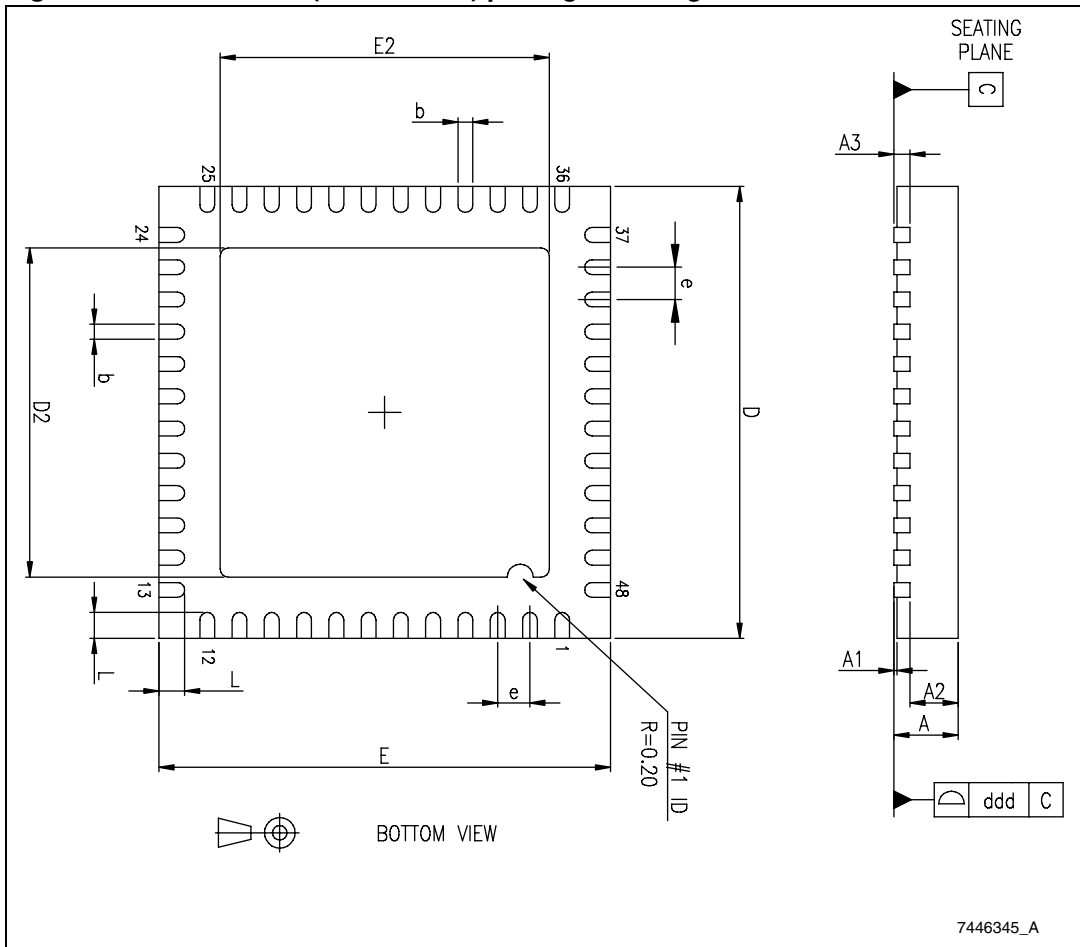

## 11 Revision history

**Table 15. Document revision history**

Date	Revision	Changes
16-May-2007	1	Initial release
16-Jan-2008	2	Document status promoted from preliminary data to datasheet. Updated: <a href="#">Table 2 on page 6</a> , <a href="#">Table 3 on page 8</a> , <a href="#">Table 6 on page 10</a> , <a href="#">Chapter 7: Device description on page 19</a> , Added: <a href="#">Chapter 9: Application examples on page 41.</a> , <a href="#">Chapter 8.5: Layout guidelines on page 40</a>
04-May-2009	3	Updated <a href="#">Table 4 on page 8</a>

**Please Read Carefully:**

Information in this document is provided solely in connection with ST products. STMicroelectronics NV and its subsidiaries ("ST") reserve the right to make changes, corrections, modifications or improvements, to this document, and the products and services described herein at any time, without notice.

All ST products are sold pursuant to ST's terms and conditions of sale.

Purchasers are solely responsible for the choice, selection and use of the ST products and services described herein, and ST assumes no liability whatsoever relating to the choice, selection or use of the ST products and services described herein.

No license, express or implied, by estoppel or otherwise, to any intellectual property rights is granted under this document. If any part of this document refers to any third party products or services it shall not be deemed a license grant by ST for the use of such third party products or services, or any intellectual property contained therein or considered as a warranty covering the use in any manner whatsoever of such third party products or services or any intellectual property contained therein.

**UNLESS OTHERWISE SET FORTH IN ST'S TERMS AND CONDITIONS OF SALE ST DISCLAIMS ANY EXPRESS OR IMPLIED WARRANTY WITH RESPECT TO THE USE AND/OR SALE OF ST PRODUCTS INCLUDING WITHOUT LIMITATION IMPLIED WARRANTIES OF MERCHANTABILITY, FITNESS FOR A PARTICULAR PURPOSE (AND THEIR EQUIVALENTS UNDER THE LAWS OF ANY JURISDICTION), OR INFRINGEMENT OF ANY PATENT, COPYRIGHT OR OTHER INTELLECTUAL PROPERTY RIGHT.**

**UNLESS EXPRESSLY APPROVED IN WRITING BY AN AUTHORIZED ST REPRESENTATIVE, ST PRODUCTS ARE NOT RECOMMENDED, AUTHORIZED OR WARRANTED FOR USE IN MILITARY, AIR CRAFT, SPACE, LIFE SAVING, OR LIFE SUSTAINING APPLICATIONS, NOR IN PRODUCTS OR SYSTEMS WHERE FAILURE OR MALFUNCTION MAY RESULT IN PERSONAL INJURY, DEATH, OR SEVERE PROPERTY OR ENVIRONMENTAL DAMAGE. ST PRODUCTS WHICH ARE NOT SPECIFIED AS "AUTOMOTIVE GRADE" MAY ONLY BE USED IN AUTOMOTIVE APPLICATIONS AT USER'S OWN RISK.**

Resale of ST products with provisions different from the statements and/or technical features set forth in this document shall immediately void any warranty granted by ST for the ST product or service described herein and shall not create or extend in any manner whatsoever, any liability of ST.

ST and the ST logo are trademarks or registered trademarks of ST in various countries.

Information in this document supersedes and replaces all information previously supplied.

The ST logo is a registered trademark of STMicroelectronics. All other names are the property of their respective owners.

© 2009 STMicroelectronics - All rights reserved

STMicroelectronics group of companies

Australia - Belgium - Brazil - Canada - China - Czech Republic - Finland - France - Germany - Hong Kong - India - Israel - Italy - Japan - Malaysia - Malta - Morocco - Philippines - Singapore - Spain - Sweden - Switzerland - United Kingdom - United States of America

[www.st.com](http://www.st.com)