

- Digital UV index sensor
 - 0-15 UV index output range
 - Resolution UVI/16
 - Selectable readout: 1 Hz ODR / one shot
- ECOPACK®, RoHS, and "Green" compliant

Applications

- Tablets and mobile phones
- Gaming and virtual reality input devices
- Wellness and wearable devices
- Drones and robotics
- IoT devices such as industrial and factory automation machines

Features

- Analog supply voltage: 1.91 V to 3.6 V
- Digital supply voltage I/Os: 1.8 V
- Power-down, "always on" eco power mode
- Motion MEMS sensors:
 - 3D accelerometer sensor
±2/±4/±8/±16g selectable full-scale acceleration range
 - 3D gyroscope sensor
±125/±245/±500/±1000/±2000dps selectable full-scale angular rate range
 - 3D magnetometer ±4/±8/±12/±16gauss selectable full-scale magnetic field range
- Environmental sensors:
 - High accuracy pressure sensor
 - Piezo-resistive pressure sensor
 - 260-1260 mbar absolute pressure range
 - Low power consumption
 - Low noise (0.0075 hPa RMS)
- Humidity and temperature sensor
 - 0 to 100% RH range
 - -40 to +85 °C temperature range
 - 16 bit ADC measurement

Description

ST MEMS sensor module integrates the ST 3D accelerometer, 3D magnetometer, 3D gyroscope, pressure, relative humidity, ambient temperature and UV index sensors.

1 Introduction

STEVAL-MKI128V5 sensor module integrates a set of complementary motion and environmental sensors. It is a robust and easy-to-assemble building block for quick system prototyping.

The module features the following ST sensors:

- LSM6DS3H (3D Accelerometer + 3D Gyroscope)
- LIS3MDL (3D magnetometer)
- LPS22HB (pressure)
- HTS221 (humidity + temperature)
- UVIS25 (UV index)

Each sensor has dedicated drivers available for the principal operating systems. The sensor module and accompanying software form a convenient sensor subsystem solution for developing gaming, augmented reality, indoor navigation and localization-based services.

Find the relevant sensor documentation on www.st.com.

2 Block diagram

Figure 1: MEMS module block diagram

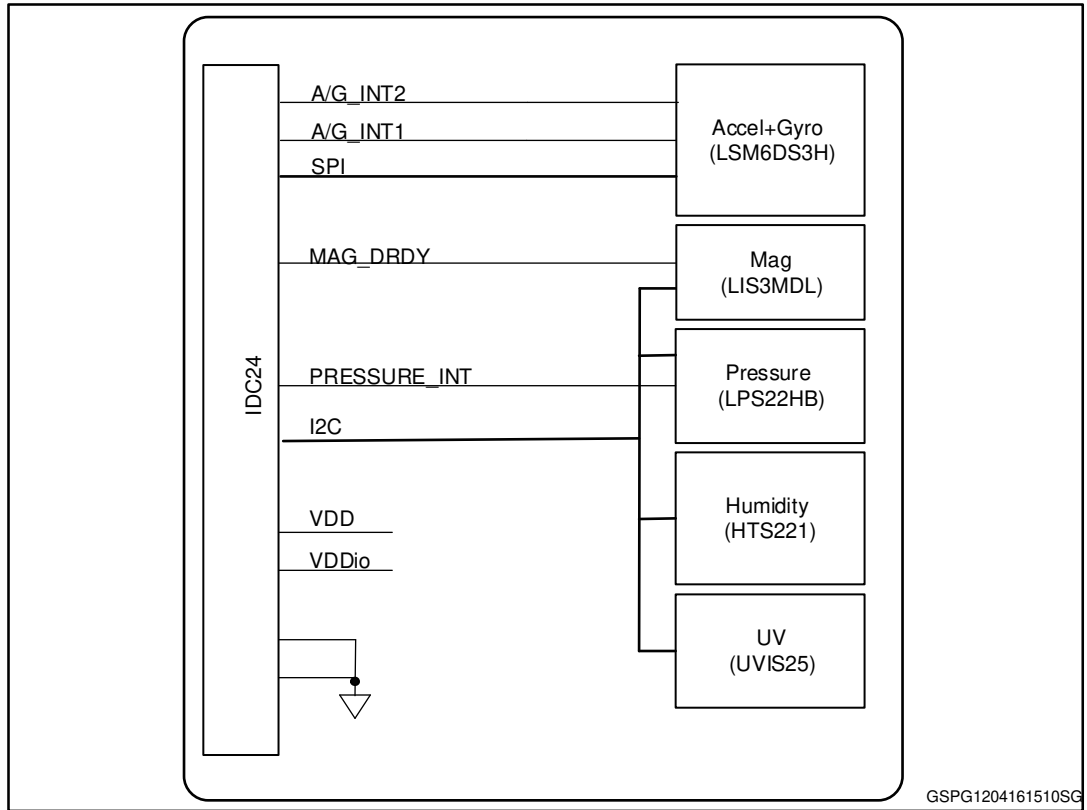

3 Application hints

Figure 2: Sensor module application example

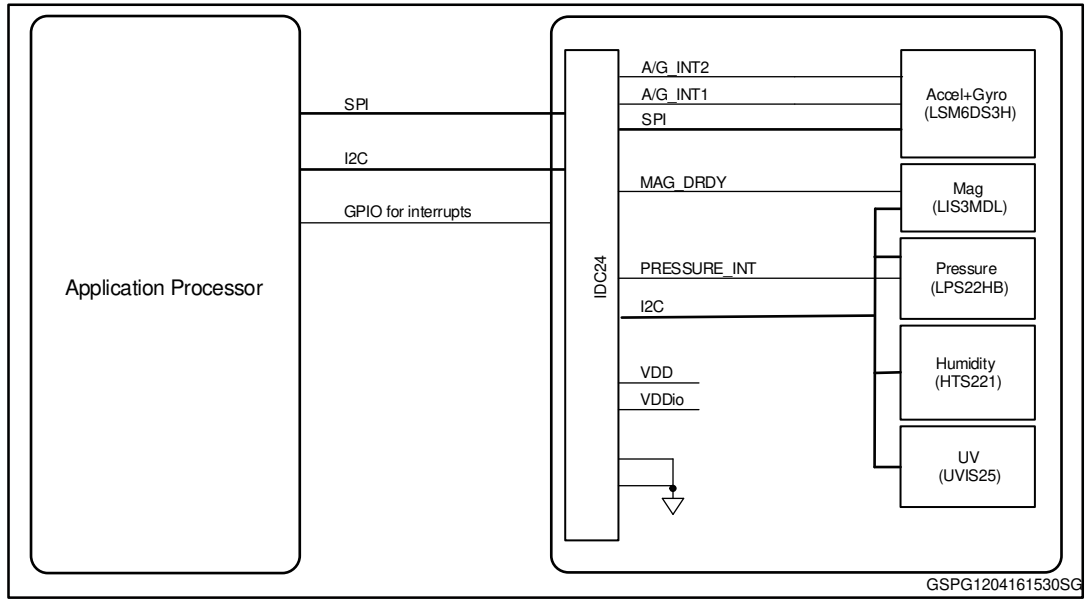

4 Schematic diagrams

Figure 3: Module schematic

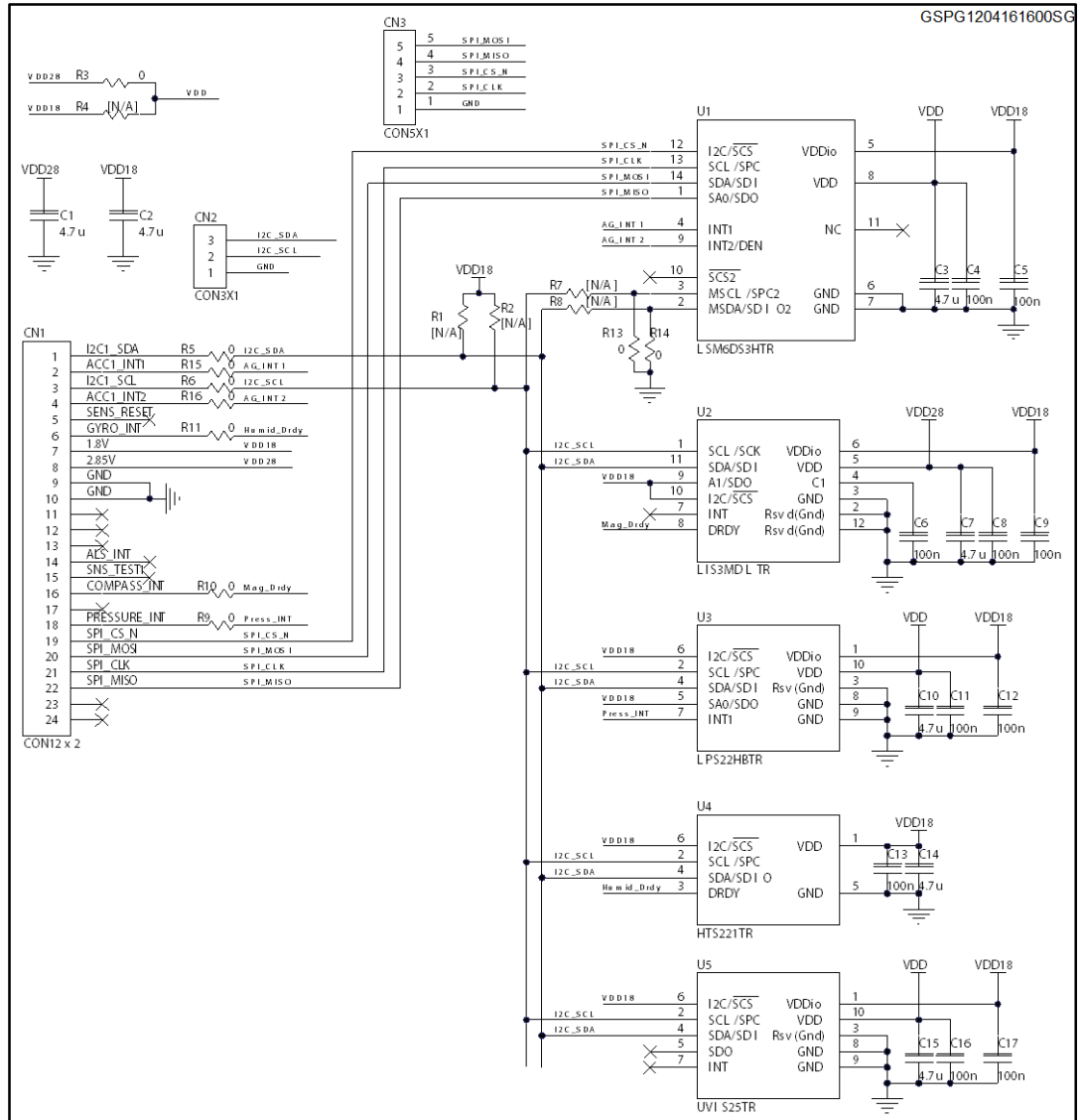

5 PCB overview

Figure 4: PCB top

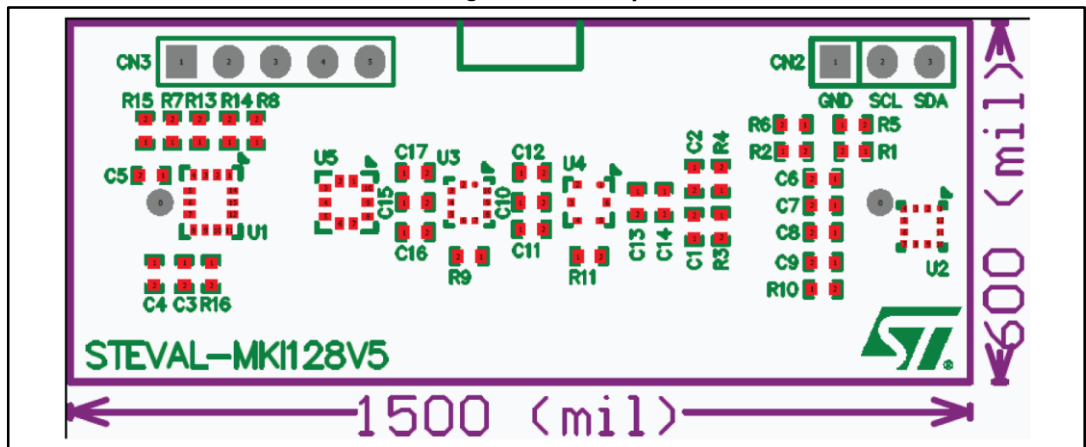
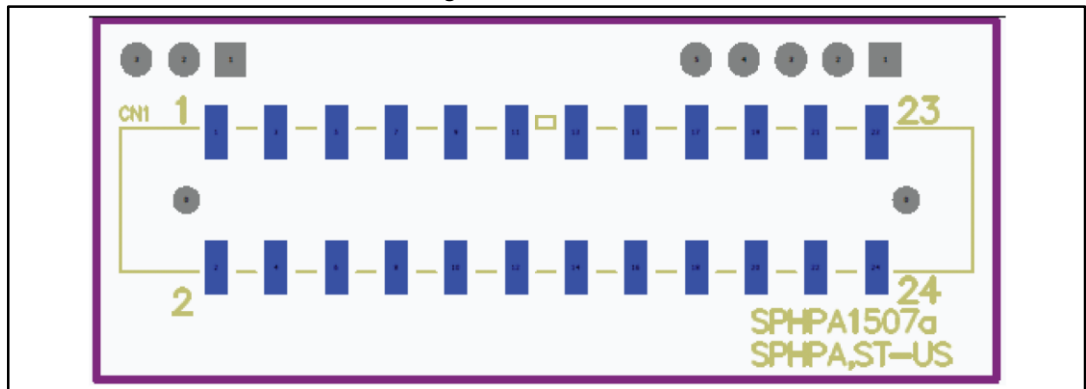

Figure 5: PCB bottom



6 Revision history

Table 1: Document revision history

Date	Version	Changes
21-Apr-2016	1	Initial release.
18-Jul-2016	2	Updated -40 to +85°C temperature range feature on the cover page.

IMPORTANT NOTICE – PLEASE READ CAREFULLY

STMicroelectronics NV and its subsidiaries ("ST") reserve the right to make changes, corrections, enhancements, modifications, and improvements to ST products and/or to this document at any time without notice. Purchasers should obtain the latest relevant information on ST products before placing orders. ST products are sold pursuant to ST's terms and conditions of sale in place at the time of order acknowledgement.

Purchasers are solely responsible for the choice, selection, and use of ST products and ST assumes no liability for application assistance or the design of Purchasers' products.

No license, express or implied, to any intellectual property right is granted by ST herein.

Resale of ST products with provisions different from the information set forth herein shall void any warranty granted by ST for such product.

ST and the ST logo are trademarks of ST. All other product or service names are the property of their respective owners.

Information in this document supersedes and replaces information previously supplied in any prior versions of this document.

© 2016 STMicroelectronics – All rights reserved