

DO NOT SCALE FROM THIS PRINT

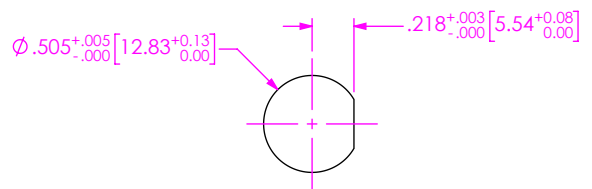

RECOMMENDED PANEL CUTOUT

DESIGNED & DIMENSIONED IN INCHES[MILLIMETERS]

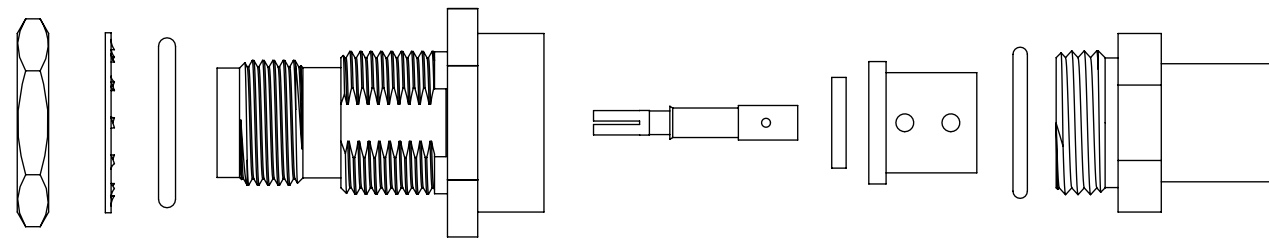
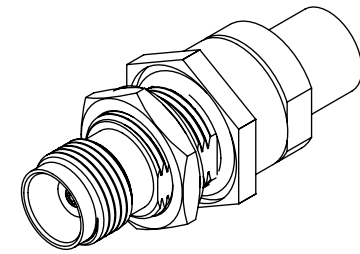
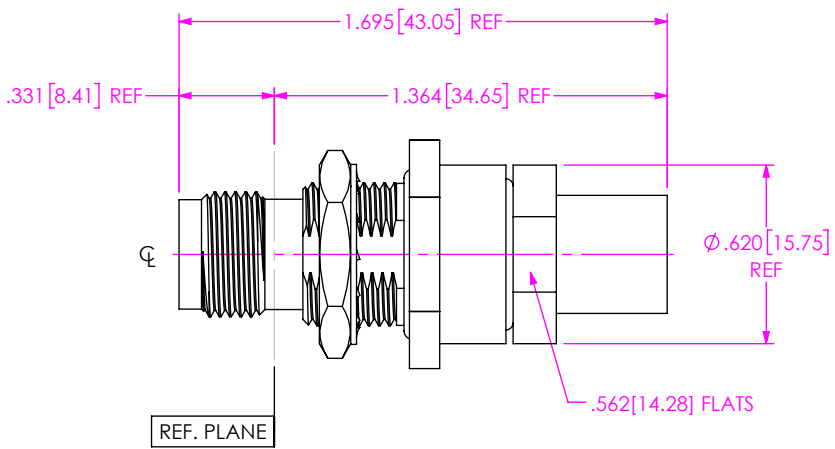
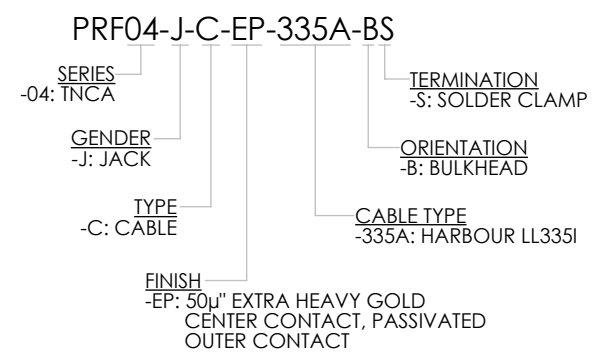

EXPLODED VIEW NOT TO SCALE (FOR CLARITY ONLY)

- NOTES:
- MATERIAL:  
 BODY, LOCK WASHER, LOCK NUT & CLAMP NUT: STAINLESS STEEL.  
 SOCKET: BERYLLIUM COPPER.  
 SOLDER FERRULE: BRASS.  
 O-RINGS: SILICONE RUBBER.  
 INSULATOR: PTFE.  
 DIELECTRIC BEAD: ULTEM 1000.
  - FINISH:  
 BODY, LOCK WASHER, LOCK NUT & CLAMP NUT: PASSIVATED.  
 CONTACT: 50μ" MIN. GOLD OVER 50μ" MIN. NICKEL PLATE.  
 SOLDER FERRULE: 10μ" MIN. GOLD OVER 50μ" MIN. NICKEL PLATE.
  - PCI P/N: 3559.

UNLESS OTHERWISE SPECIFIED, DIMENSIONS ARE IN INCHES. TOLERANCES ARE: DECIMALS                      ANGLES .XX: ±.01 [0.3]                      1° .XXX: ±.005 [0.13] .XXXX: ±.0005 [0.013]	* PROPRIETARY NOTE * THIS DOCUMENT CONTAINS CONFIDENTIAL AND PROPRIETARY INFORMATION AND ALL DESIGN, MANUFACTURING, REPRODUCTION, USE, PATENT RIGHTS AND SALES RIGHTS ARE EXPRESSLY RESERVED BY SAMTEC, INC. THIS DOCUMENT SHALL NOT BE DISCLOSED, IN WHOLE OR PART, TO ANY UNAUTHORIZED PERSON OR ENTITY NOR REPRODUCED, TRANSFERRED OR INCORPORATED IN ANY OTHER PROJECT IN ANY MANNER WITHOUT THE EXPRESS WRITTEN CONSENT OF SAMTEC, INC.	
		520 PARK EAST BLVD., NEW ALBANY, IN 47150 PHONE: 812-944-6733      FAX: 812-948-5047 e-Mail: info@SAMTEC.com      code 55322
		DESCRIPTION: TNCA BULKHEAD JACK, SOLDER CLAMP FOR HARBOUR LL335I CABLE DWG. NO. PRF04-J-C-EP-335A-BS BY: SAMUEL C      08/01/2020      SHEET 1 OF 2

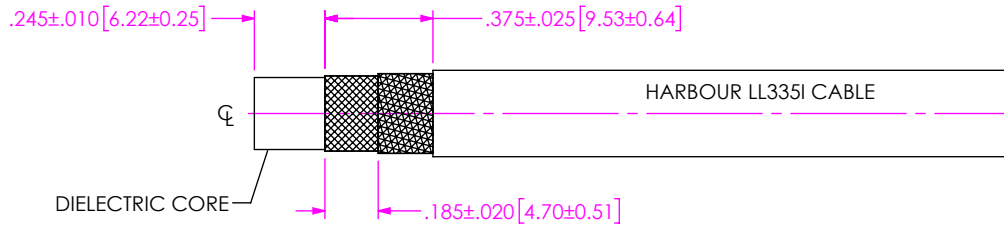

1. TRIM CABLE TO EXPOSE DIELECTRIC CORE AND BRAIDS AS SHOWN.

IN-PROCESS 1

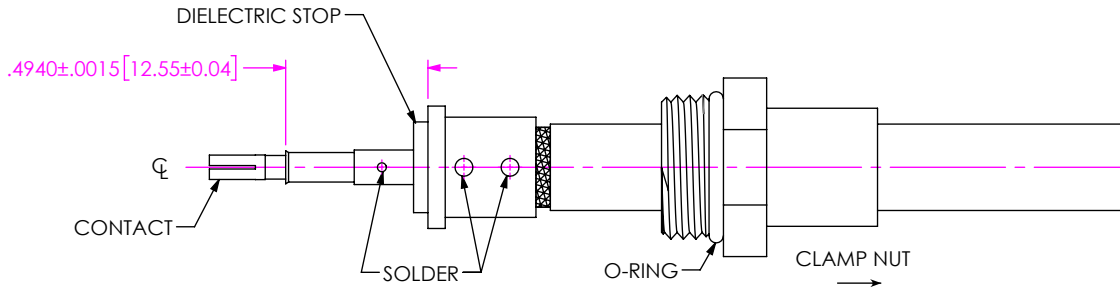

- 2A. SLIDE CLAMP NUT OVER CABLE AS SHOWN.
- 2B. INSERT CABLE INTO SOLDER FERRULE UNTIL INNER BRAID SEATS AND SOLDER TO FERRULE WHERE SHOWN.
- 2C. TRIM DIELECTRIC CORE FLUSH WITH FACE OF SOLDER FERRULE.
- 2D. SLIDE DIELECTRIC STOP ONTO CABLE CENTER CONDUCTOR AND SOLDER CONTACT FLUSH TO STOP TO DIMENSION SHOWN.

IN-PROCESS 2

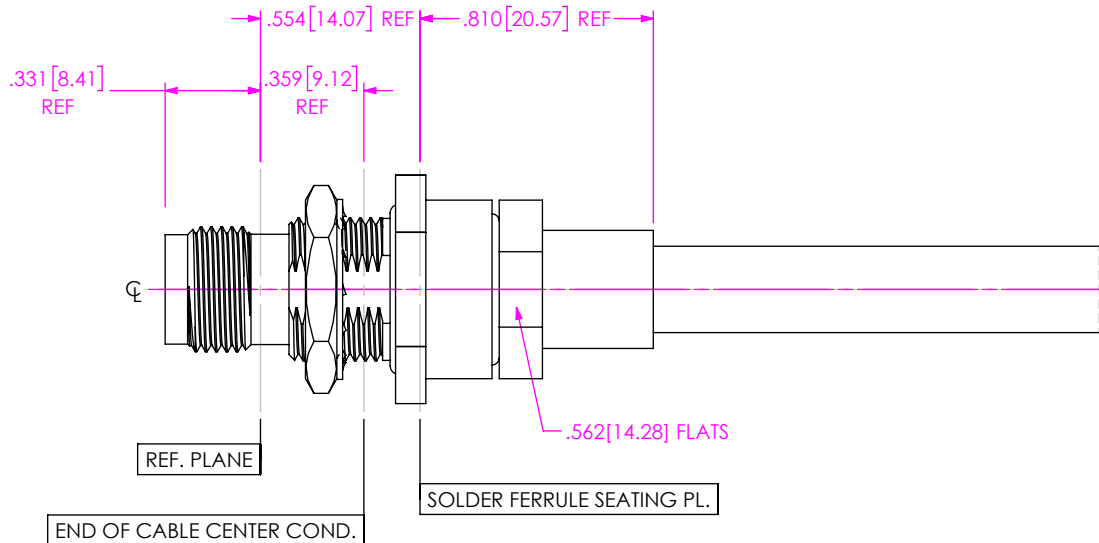

3. INSERT CABLE/CONTACT SUB-ASSEMBLY INTO CONNECTOR UNTIL SEATED AND TIGHTEN CLAMP NUT TO 25-35 IN-LBS.

IN-PROCESS 3

<p>DO NOT SCALE DRAWING</p> <p>SHEET SCALE: 1.5:1</p>	<p><b>PROPRIETARY NOTE</b></p> <p>THIS DOCUMENT CONTAINS CONFIDENTIAL AND PROPRIETARY INFORMATION AND ALL DESIGN, MANUFACTURING, REPRODUCTION, USE, PATENT RIGHTS AND SALES RIGHTS ARE EXPRESSLY RESERVED BY SAMTEC, INC. THIS DOCUMENT SHALL NOT BE DISCLOSED, IN WHOLE OR PART, TO ANY UNAUTHORIZED PERSON OR ENTITY NOR REPRODUCED, TRANSFERRED OR INCORPORATED IN ANY OTHER PROJECT IN ANY MANNER WITHOUT THE EXPRESS WRITTEN CONSENT OF SAMTEC, INC.</p>	<p><b>samtec</b></p> <p>520 PARK EAST BLVD, NEW ALBANY, IN 47150                  PHONE: 812-944-6733 FAX: 812-948-5047                  e-Mail: info@SAMTEC.com code 55322</p>
	<p>DESCRIPTION: TNCA BULKHEAD JACK, SOLDER CLAMP FOR HARBOUR LL335I CABLE</p>	
	<p>DWG. NO. PRF04-J-C-EP-335A-BS</p>	
<p>BY: SAMUEL C 08/01/2020 SHEET 2 OF 2</p>		