



# High-Precision, +2.5V Reference

**MX580**

## General Description

The MX580 is a high-performance, three-terminal voltage reference which provides a stable +2.5V source for 8-, 10-, and 12-bit data converters and analog functions. A temperature-compensated internal bandgap operates from 4.5V to 30V and consumes only 1.5mA.

The reference can be connected directly to a number of CMOS analog-to-digital and digital-to-analog converters and is especially convenient in +5V powered systems. An initial untrimmed accuracy of 0.4% and temperature stability of 10ppm/°C allow adjustment-free designs in many precision applications.

Available packages include TO-52 metal cans for commercial and military temperature grades, as well as 8-pin SO packages for commercial grade devices.

## Applications

- CMOS Data Conversion
- Digital Panel Meters
- Portable Instrumentation
- Remote Measurement Systems
- Logic-Powered Analog Systems

## Features

- ◆ 2.500V ±0.4% Accuracy (MX580L/M)
- ◆ 10ppm/°C Temperature Stability (MX580M)
- ◆ No Adjustments
- ◆ 250µV Long-Term Stability
- ◆ 1.5mA Quiescent Current
- ◆ 4.5V to 30V Operation

## Ordering Information

PART	TEMP RANGE	PIN-PACKAGE	TOLERANCE
MX580JH	0°C to +70°C	TO-52 Can	±75mV
MX580KH	0°C to +70°C	TO-52 Can	±25mV
MX580LH	0°C to +70°C	TO-52 Can	±10mV
MX580MH	0°C to +70°C	TO-52 Can	±10mV
MX580JCSA	0°C to +70°C	8 SO	±75mV
MX580KCSA	0°C to +70°C	8 SO	±25mV
MX580LCSA	0°C to +70°C	8 SO	±10mV
MX580JESA	-40°C to +85°C	8 SO	±75mV
MX580KESA	-40°C to +85°C	8 SO	±25mV
MX580SH	-55°C to +125°C	TO-52 Can	±25mV

## Typical Application Circuit

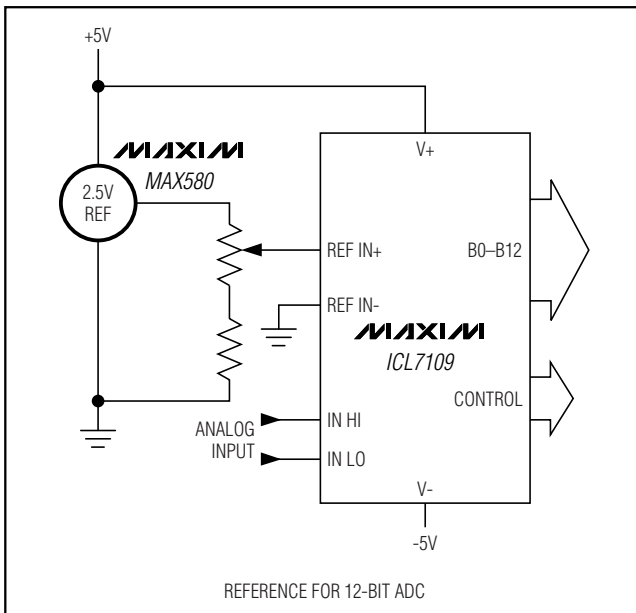

## Pin Configurations

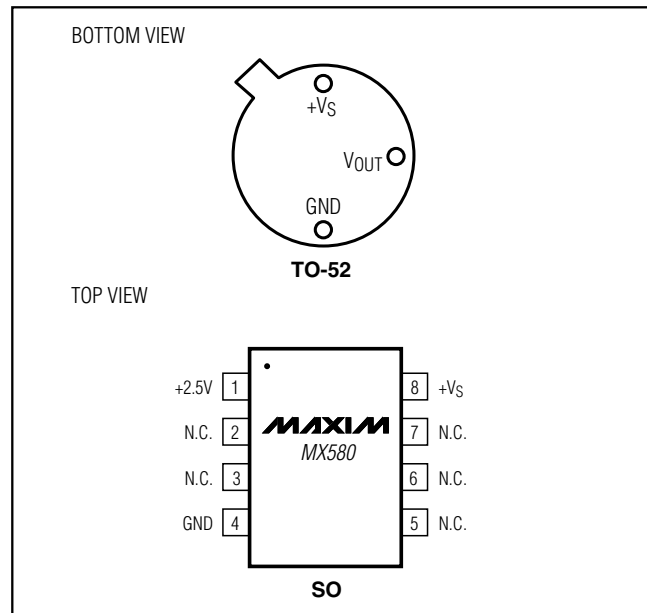

**For pricing, delivery, and ordering information, please contact Maxim/Dallas Direct! at 1-888-629-4642, or visit Maxim's website at [www.maxim-ic.com](http://www.maxim-ic.com).**

# High-Precision, +2.5V Reference

## ABSOLUTE MAXIMUM RATINGS

Input Voltage ( $V_{IN}$ to GND) .....	-0.3V, +40V
Continuous Power Dissipation	
TO-52 Metal Can (derate 2.8mW/°C above +25°C) .....	350mW
SO (derate 5.3mW/°C above +75°C) .....	400mW
Output Short-Circuit Duration (Note 1) .....	Indefinite
Operating Temperature Range	
Commercial (J, K, L, M) .....	0°C to +70°C
Military (S) .....	-55°C to +125°C

Storage Temperature Range .....	-65°C to +175°C
Lead Temperature (soldering, 10s) .....	+300°C
Thermal Resistance, Junction to Ambient	
TO-52 Metal Can .....	+360°C/W
SO .....	+170°C/W
Junction to Case	
TO-52 Metal Can .....	+100°C/W
SO .....	+55°C/W

**Note 1:** Absolute maximum power dissipation must not be exceeded.

Stresses beyond those listed under "Absolute Maximum Ratings" may cause permanent damage to the device. These are stress ratings only, and functional operation of the device at these or any other conditions beyond those indicated in the operational sections of the specifications is not implied. Exposure to absolute maximum rating conditions for extended periods may affect device reliability.

## ELECTRICAL CHARACTERISTICS

( $V_{IN} = +15V$ .  $T_A = +25°C$ , unless otherwise noted.)

PARAMETER	SYMBOL	CONDITIONS	MIN	TYP	MAX	UNITS
Output Voltage Tolerance		$I_L = 0mA$	MX580J/S		±75	mV
			MX580K		±25	
			MX580L/M		±10	
Output Voltage Change with Temperature (Temperature Coefficient)		$T_A = 0°C$ to +75°C	MX580J		15 (85)	mV (ppm/°C)
			MX580K		7 (40)	
			MX580L		4.3 (25)	
		$T_A = -40°C$ to +85°C	MX580M		1.75 (10)	
			MX580J		20 (64)	
			MX580K		12 (38)	
$T_A = -55°C$ to +125°C	MX580S		25 (55)			
Line Regulation		$I_L = 0mA$ , $4.5V < V_{IN} < 7V$	MX580J/S	0.3	3	mV
			MX580K	0.3	2	
			MX580L/M		1	
		$I_L = 0mA$ , $7V < V_{IN} < 30V$	MX580J/S	1.5	6	
			MX580K	1.5	4	
			MX580L/M		2	
Load Regulation		$I_L = 0mA$ to 10mA			10	mV
Quiescent Supply Current	$I_Q$	$I_L = 0mA$		1.0	1.5	mA
Noise	$e_n(P-P)$	0.1Hz to 10Hz		60		$\mu V_{P-P}$
Stability		Long term		250		$\mu V$
		Per month		25		

# High-Precision, +2.5V Reference

**MX580**

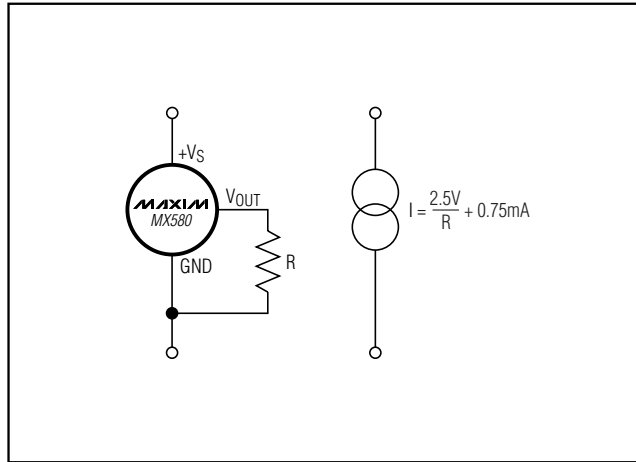

Figure 1. Two-Component Precision Current Limiter

# High-Precision, +2.5V Reference

## Package Information

(The package drawing(s) in this data sheet may not reflect the most current specifications. For the latest package outline information, go to [www.maxim-ic.com/packages](http://www.maxim-ic.com/packages).)

SYMBOL	INCHES		MILLIMETERS	
	MIN	MAX	MIN	MAX
A	.115	.150	2.92	3.81
f b	---	.021	---	.533
f b2	.016	.019	.406	.483
f D	.209	.230	5.31	5.84
f D1	.178	.195	4.52	4.95
e	.100 T.P.		2.54 T.P.	
e1	.050 T.P.		1.27 T.P.	
F	---	.030	---	.762
J	.036	.046	.914	1.17
k	.028	.048	.711	1.22
L	.500	---	12.70	---
L1	---	.050	---	1.27
L2	.250	---	6.35	---
Q	45° T.P.		45° T.P.	

NOTES: DIMENSIONS ARE COMPLIANT TO JEDEC, TO-52.

TOLERANCES UNLESS OTHERWISE SPECIFIED FRACTIONS DEC ANGLES ± N/A ±.001 ± N/A		<b>MAXIM</b> PROPRIETARY INFORMATION
DRAWN BY:	DATE:	
TITLE: CASE OUTLINE TO-52, 2 LD		APPROVED BY: DATE: DOCUMENT CONTROL NO. REV. A
APPROVED BY: DATE: 21-0020		

TO52/PO EFS

DIM	INCHES		MILLIMETERS	
	MIN	MAX	MIN	MAX
A	0.053	0.069	1.35	1.75
A1	0.004	0.010	0.10	0.25
B	0.014	0.019	0.35	0.49
C	0.007	0.010	0.19	0.25
e	0.050 BSC		1.27 BSC	
E	0.150	0.157	3.80	4.00
H	0.228	0.244	5.80	6.20
L	0.016	0.050	0.40	1.27

VARIATIONS:

DIM	INCHES		MILLIMETERS		N	MS012
	MIN	MAX	MIN	MAX		
D	0.189	0.197	4.80	5.00	8	AA
D	0.337	0.344	8.55	8.75	14	AB
D	0.386	0.394	9.80	10.00	16	AC

NOTES:  
 1. D&E DO NOT INCLUDE MOLD FLASH.  
 2. MOLD FLASH OR PROTRUSIONS NOT TO EXCEED 0.15mm (.006").  
 3. LEADS TO BE COPLANAR WITHIN 0.10mm (.004").  
 4. CONTROLLING DIMENSION: MILLIMETERS.  
 5. MEETS JEDEC MS012.  
 6. N = NUMBER OF PINS.

DALLAS SEMICONDUCTOR <b>MAXIM</b> PROPRIETARY INFORMATION	
TITLE: PACKAGE OUTLINE, .150" SOIC	
APPROVAL:	DOCUMENT CONTROL NO. REV. 1/1
	21-0041 B

SOIC EFS

Maxim cannot assume responsibility for use of any circuitry other than circuitry entirely embodied in a Maxim product. No circuit patent licenses are implied. Maxim reserves the right to change the circuitry and specifications without notice at any time.

4 **Maxim Integrated Products, 120 San Gabriel Drive, Sunnyvale, CA 94086 408-737-7600**