

RECOMMENDED PCB PATTERN LAYOUT
TOLERANCE : ±0.05

* : cpk MEASURE POINTS

NOTES

1. MATERIALS SHEE CHART
2. FINISHES SHEE CHART
3. PRODUCT SPECIFICATION : PS-49446-001
4. COPLANARITY OF SOLDER TAILS : 0.1mm MAX.
MISALIGNMENT OF SOLDER TAIL FROM "Z" UPPER DIRECTION 0.05 MAX., LOWER DIRECTION 0.1MAX.
5. PACKAGING SPECIFICATION : PK-49446-001

NO.	DESCRIPTION	MATERIALS	REMARK
⑥	SPRING	STAINLESS STEEL	Ni plated
⑤	PIN ROD	STAINLESS STEEL	Ni plated
④	HEART CAM	LIQUID CRYSTAL POLYMER	UL94V-0, GLASS FILLED
③	HOUSING	LIQUID CRYSTAL POLYMER	UL94V-0, GLASS FILLED
②	METAL SHELL	STAINLESS STEEL	Selective-Au over Ni
①	CONTACT TERMINAL	PHOS.-BRONZE	Selective-Au over Ni

NEW RELEASED
EC NO: KOR2008-0113
DRWN: SINGHYUK JOO 2008/01/10
CHKD: S. J. SEH 2008/01/10
APPR: YUNSI KKK IM 2008/01/10

REV	DESCRIPTION
A	

QUALITY SYMBOLS		GENERAL TOLERANCES (UNLESS SPECIFIED)		DIMENSION STYLE		SCALE	DESIGN UNITS	THIRD ANGLE PROJECTION	
$\nabla=0$	$\nabla=0$	mm	INCH	MM ONLY		4:1	METRIC	THIRD ANGLE PROJECTION	
4 PLACES	± ---	± ---	± ---	DRAWN BY	DATE	TITLE SIM CARD SOCKET-8P PUSG/PUSH TYPE			
3 PLACES	± ---	± ---	± ---	S. H. JOO	2008/01/08				
2 PLACES	± 0.15	± ---	± ---	CHECKED BY	DATE				
1 PLACE	± 0.2	± ---	± ---	S. J. SEH	2008/01/08				
ANGULAR ± 1 °				APPROVED BY	DATE				
DRAFT WHERE APPLICABLE MUST REMAIN WITHIN DIMENSIONS				E. H. JUNG		2008/01/08	MATERIAL NO. SD-49446-001		

MATERIAL NO.		ENGINEERING NO.	
494460811		49446-0811	
SD-49446-001		SD-49446-001	

MATERIAL NO.		ENGINEERING NO.	
494460811		49446-0811	
SD-49446-001		SD-49446-001	
DOCUMENT NO.		SHEET NO.	
SD-49446-001		1 OF 2	

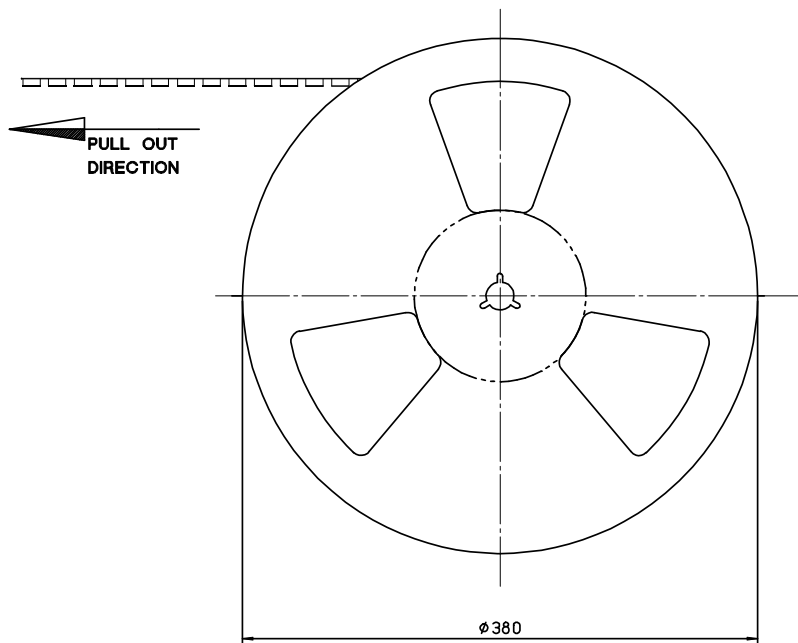

NOTES

1. QUANTITY OF CONNECTORS : 1,000PCS/REEL
2. LEAD LENGTH

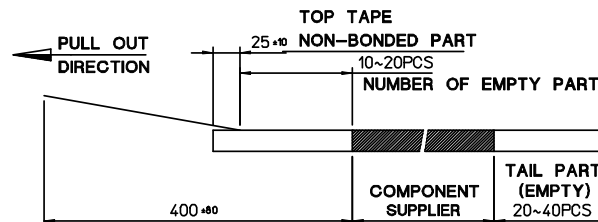

3. PEELING OFF FORCE OF COVER TAPE : 0.1N~0.59N(10.2GF~60GF)
(PEELING DIRECTION AS SHOW IN FOLLOW FIG.)
- PEELING OFF SPEED : 300mm/MIn.(Ref.)

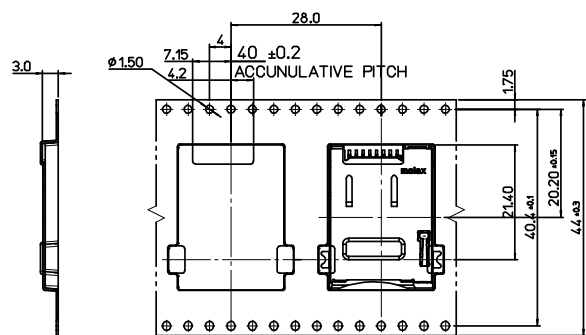
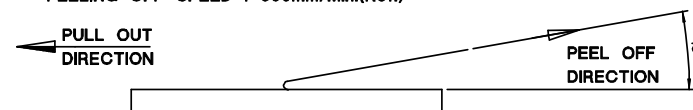

35902-0012	35908-0048	49446-9901	49446-0811	494460811	49446-0811	8P
COVER TAPE	REEL	EMBOSSD TAPE	CONNECTOR	MATERIAL NO.	ENG. NO.	CKTS

NEW RELEASED EC NO: KOR2008-0113 DRWN: SUNGHYUK JOO 2008/01/10 CHKD: S. J. SEH 2008/01/10 APPR: YUNS IKK IM 2008/01/10	DESCRIPTION REV A	QUALITY SYMBOLS ▽=0 ▽=0	GENERAL TOLERANCES (UNLESS SPECIFIED) mm INCH	DIMENSION STYLE MM ONLY	SCALE 4:1	DESIGN UNITS METRIC	THIRD ANGLE PROJECTION
		4 PLACES ± --- ± --- 3 PLACES ± --- ± --- 2 PLACES ± 0.15 ± --- 1 PLACE ± 0.2 ± ---	DRAWN BY DATE S.H. JOO 2008/01/08 CHECKED BY DATE S. J. SEH 2008/01/08 APPROVED BY DATE E. H. JUNG 2008/01/08	TITLE SIM CARD SOCKET-8P PUSH/PUSH TYPE			
		ANGULAR ± 1 °	MATERIAL NO. SD-49446-001	DOCUMENT NO. SD-49446-001	SHEET NO. 2 OF 2		
		DRAFT WHERE APPLICABLE MUST REMAIN WITHIN DIMENSIONS		THIS DRAWING CONTAINS INFORMATION THAT IS PROPRIETARY TO MOLEX INCORPORATED AND SHOULD NOT BE USED WITHOUT WRITTEN PERMISSION			