

10	9	8	7	6	5	4	3	2	1
							ASSEMBLY	KAPTON TAPE	PACKAGING
							87713-1005	NO	TRAY
							87713-1006	YES	TAPE & REEL

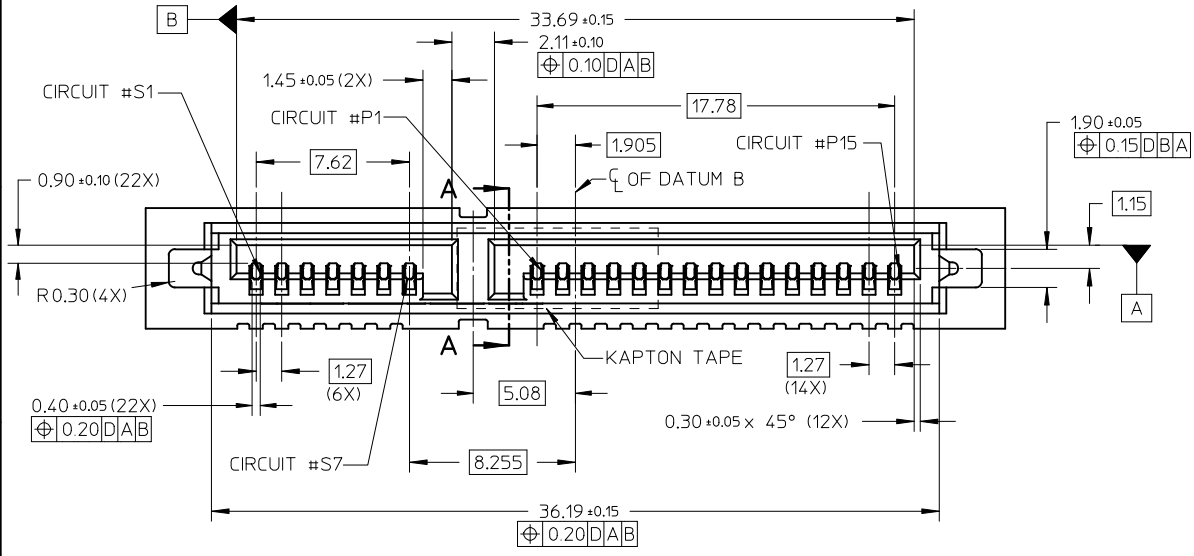

- NOTES:
- MATERIAL: LCP, GLASS FILLED, UL 94V-0, COLOR: BLACK
TERMINAL: COPPER ALLOY
 - PLATING:
CONTACT: 0.76µm MIN. SELECTIVE GOLD OVER 1.27µm MIN. NICKEL UNDERPLATE
SOLDERTAIL: 2.54µ MIN. TIN OVER 1.27 µm MIN. NICKEL UNDERPLATE
 - MOLEX LOGO LOCATED APPROXIMATELY AS SHOWN
 - MAXIMUM WARPAGE OF 0.13 mm OVER THE LENGTH OF THE CONNECTOR IN ANY DIRECTION BEFORE AND AFTER EXPOSURE TO MAX. 260°C FOR 10 SECONDS
 - PRODUCT SPECIFICATION: PS-87713-016 APPLIES
 - PACKAGING
30 CONNECTORS PER TRAY
 - KAPTON TAPE : 11.00mm X 4.00mm. KAPTON TAPE LOCATION IS CENTERED ALONG THE PART AS SHOWN. TOP SURFACE OF TAPE TO BE FLAT FOR THE PURPOSE OF PICK & PLACE.

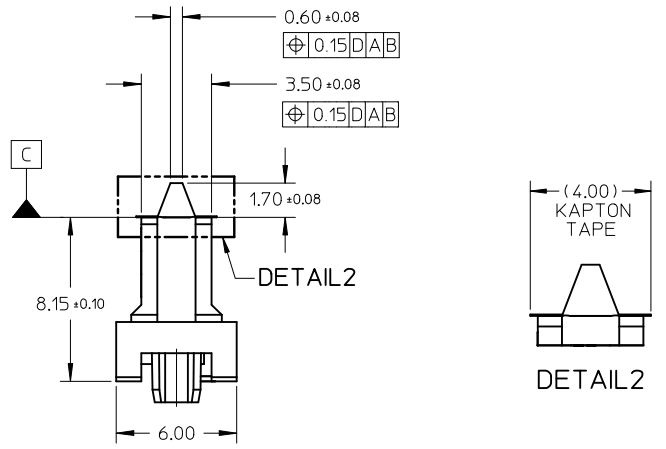
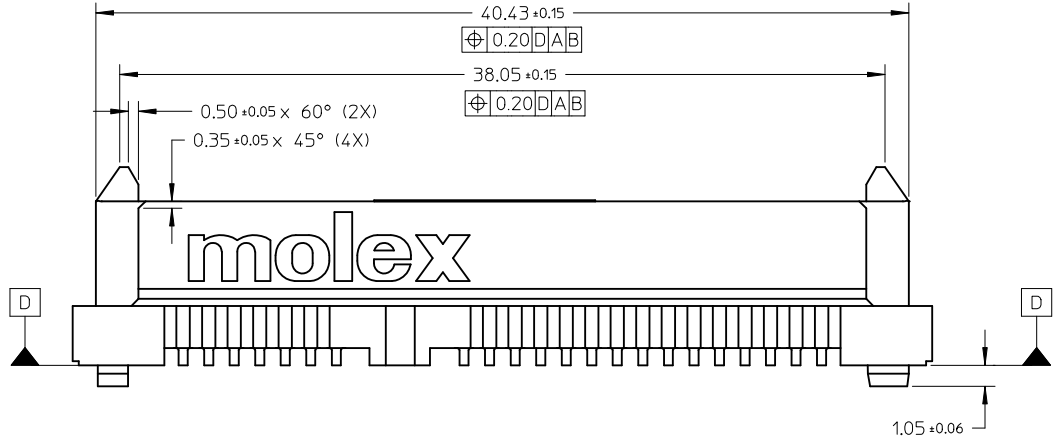

SHTS. UPDATE E/TAPE EC NO: S2012-0010 DRWN:ATSEE 2011/07/05 CH'KD:SKANG 2011/07/11 APPR:MLONG 2011/07/11	QUALITY SYMBOLS F=0 F=0 F=0	GENERAL TOLERANCES (UNLESS SPECIFIED)		DIMENSION STYLE MM ONLY		SCALE NTS	DESIGN UNITS METRIC	THIRD ANGLE PROJECTION			
		4 PLACES ± --- ± --- 3 PLACES ± --- ± --- 2 PLACES ± 0.20 ± --- 1 PLACE ± --- ± ---	mm INCH ± --- ± --- ± 0.20 ± --- ± --- ± ---	DRAWN BY KHLIM	DATE 2005/03/07	TITLE SERIAL ATA BACKPLANE SIL WITH 1.05 PEGS STD HEIGHT, RECEPT., SMT					
		ANGULAR ± 3 °		CHECKED BY KCLING	DATE 2005/04/14	MOLEX INCORPORATED					
		DRAFT WHERE APPLICABLE MUST REMAIN WITHIN DIMENSIONS		APPROVED BY SKTOH	DATE 2005/04/14	MATERIAL NO. SEE TABLE		DOCUMENT NO. SD-87713-029	SHEET NO. 1 OF 5		

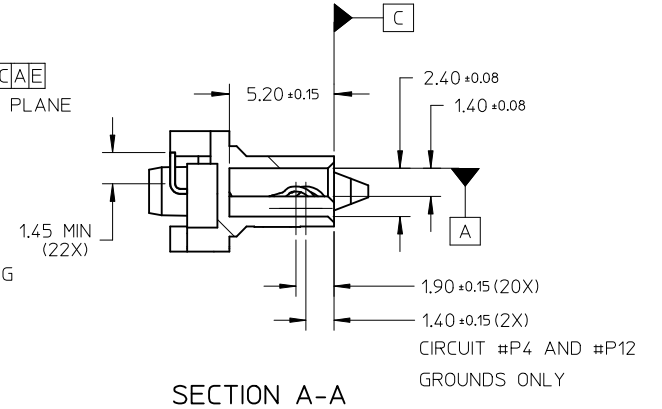
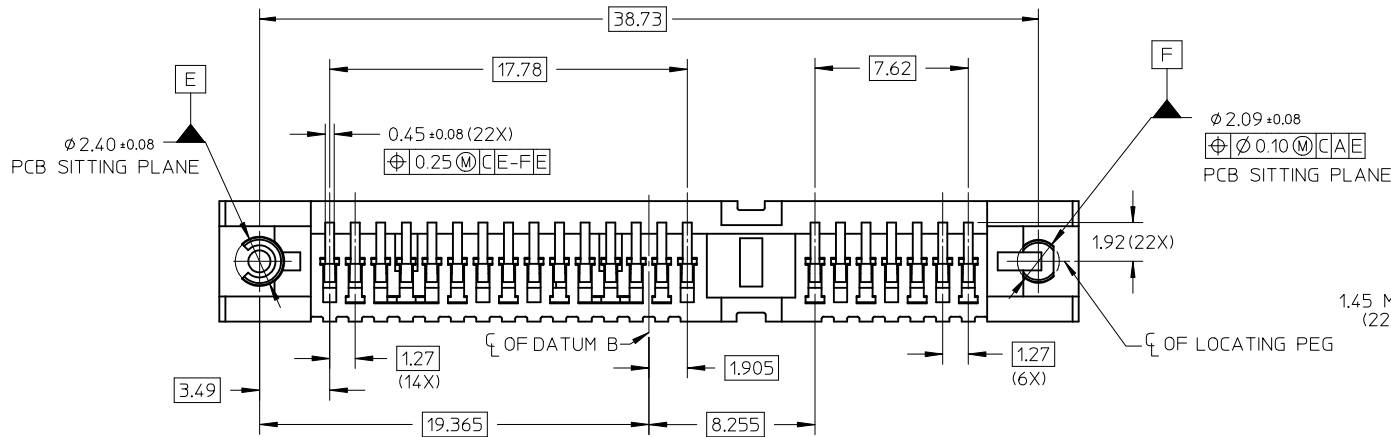
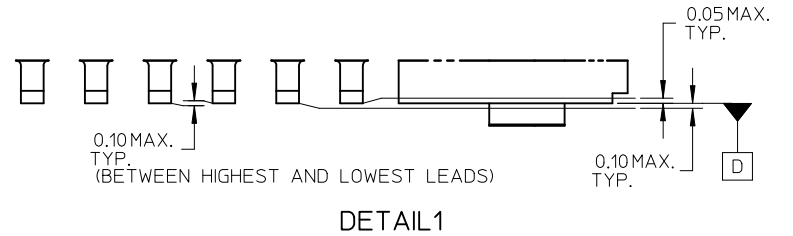
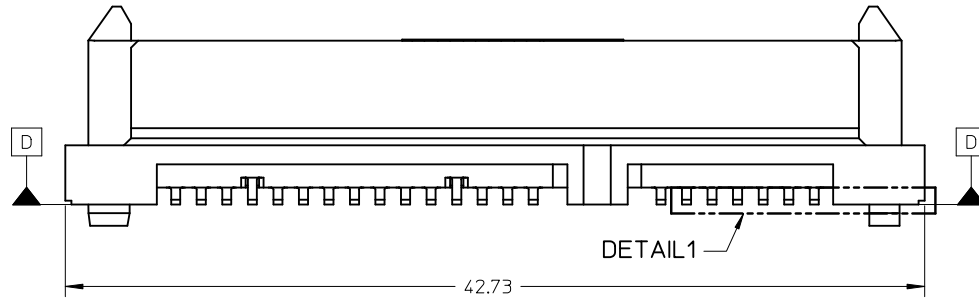

SHTS, UPDATE E/TAPE EC NO: S2012-0010 DRW:WATSEE 2011/07/05 CHK'D:SKANG 2011/07/11 APPR:MLONG 2011/07/11	DESCRIPTION REV	QUALITY SYMBOLS	GENERAL TOLERANCES (UNLESS SPECIFIED)		DIMENSION STYLE MM ONLY		SCALE NTS	DESIGN UNITS METRIC	THIRD ANGLE PROJECTION	
		$F_A = 0$ $F_C = 0$ $F_B = 0$	mm INCH 4 PLACES ± --- ± --- 3 PLACES ± --- ± --- 2 PLACES ± 0.20 ± --- 1 PLACE ± --- ± --- ANGULAR ± 3 °	DRAWN BY: KHLIM DATE: 2005/03/07 CHECKED BY: KCLING DATE: 2005/04/14 APPROVED BY: SKTOH DATE: 2005/04/14	TITLE		SERIAL ATA BACKPLANE SIL WITH 1.05 PEGS STD HEIGHT, RECEPT., SMT			
		DRAFT WHERE APPLICABLE MUST REMAIN WITHIN DIMENSIONS	MATERIAL NO. SEE TABLE	MOLEX INCORPORATED		DOCUMENT NO. SD-87713-029	SHEET NO. 2 OF 5			
		SIZE A3	THIS DRAWING CONTAINS INFORMATION THAT IS PROPRIETARY TO MOLEX INCORPORATED AND SHOULD NOT BE USED WITHOUT WRITTEN PERMISSION							

10 9 8 7 6 5 4 3 2 1

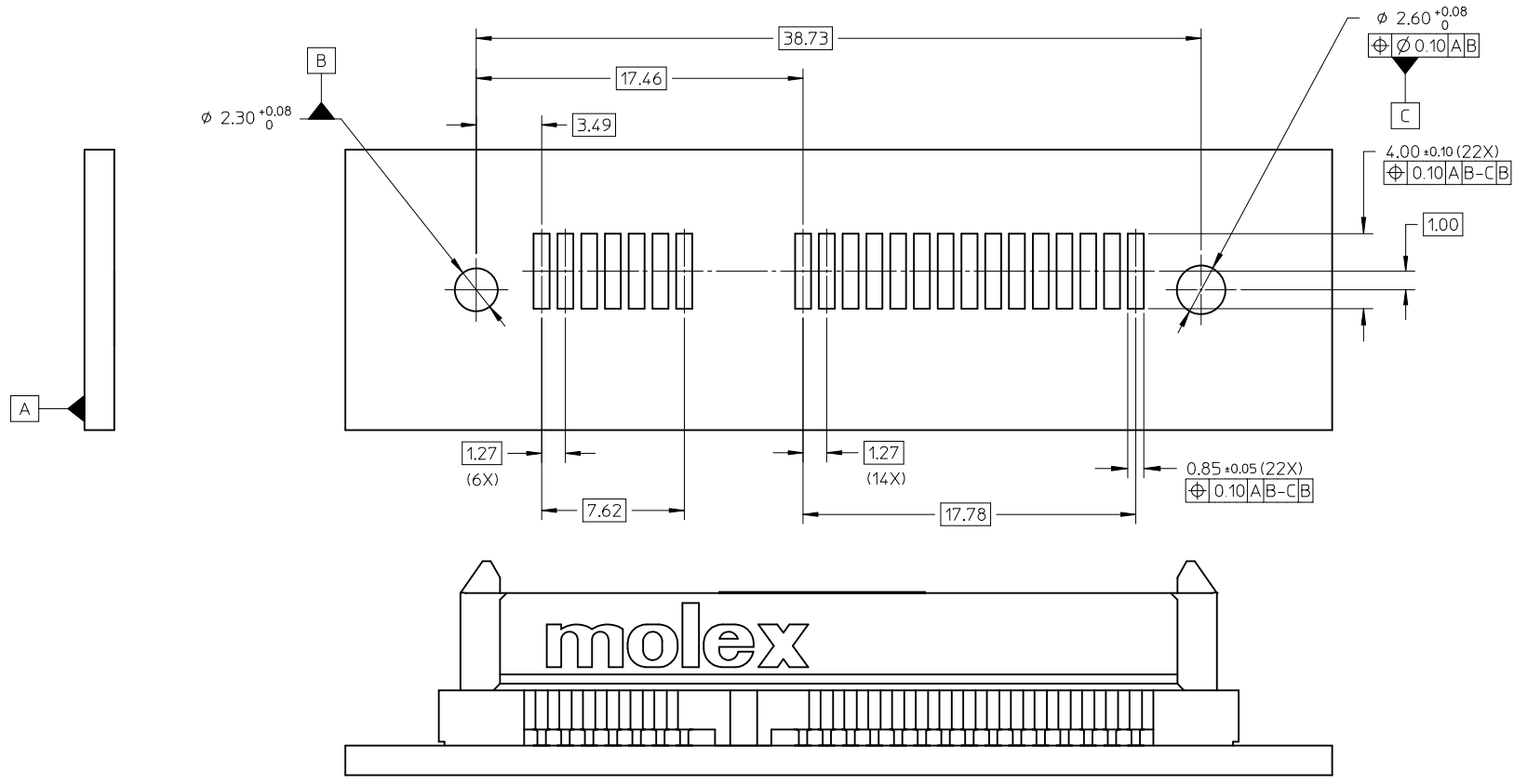

PCB THICKNESS: 1.60±0.10 mm
RECOMMENDED PCB LAYOUT

SHT5. UPDATE E/TAPE EC NO: S2012-0010 DRWN:ATSEE 2011/07/05 CHKD:SKANG 2011/07/11 APPR:MLONG 2011/07/11 REV B4	DESCRIPTION REV	QUALITY SYMBOLS	GENERAL TOLERANCES (UNLESS SPECIFIED)	DIMENSION STYLE	SCALE	DESIGN UNITS	THIRD ANGLE PROJECTION
		$F_A=0$ $F_G=0$ $F_P=0$	(UNLESS SPECIFIED) mm INCH	MM ONLY	NTS	METRIC	
		4 PLACES ± --- ± --- 3 PLACES ± --- ± --- 2 PLACES ± 0.20 ± --- 1 PLACE ± --- ± --- ANGULAR ± 3 °	DRAWN BY: KHL IM CHECKED BY: KCL ING APPROVED BY: SKTOH MATERIAL NO.	DATE: 2005/03/07 DATE: 2005/04/14 DATE: 2005/04/14	TITLE: SERIAL ATA BACKPLANE SIL WITH 1.05 PEGS STD HEIGHT, RECEPT., SMT MOLEX MOLEX INCORPORATED	DOCUMENT NO. SD-87713-029	SHEET NO. 3 OF 5
		DRAFT WHERE APPLICABLE MUST REMAIN WITHIN DIMENSIONS	SEE TABLE	THIS DRAWING CONTAINS INFORMATION THAT IS PROPRIETARY TO MOLEX INCORPORATED AND SHOULD NOT BE USED WITHOUT WRITTEN PERMISSION			

9 8 7 6 5 4 3 2 1

10 9 8 7 6 5 4 3 2 1

F

E

D

C

B

A

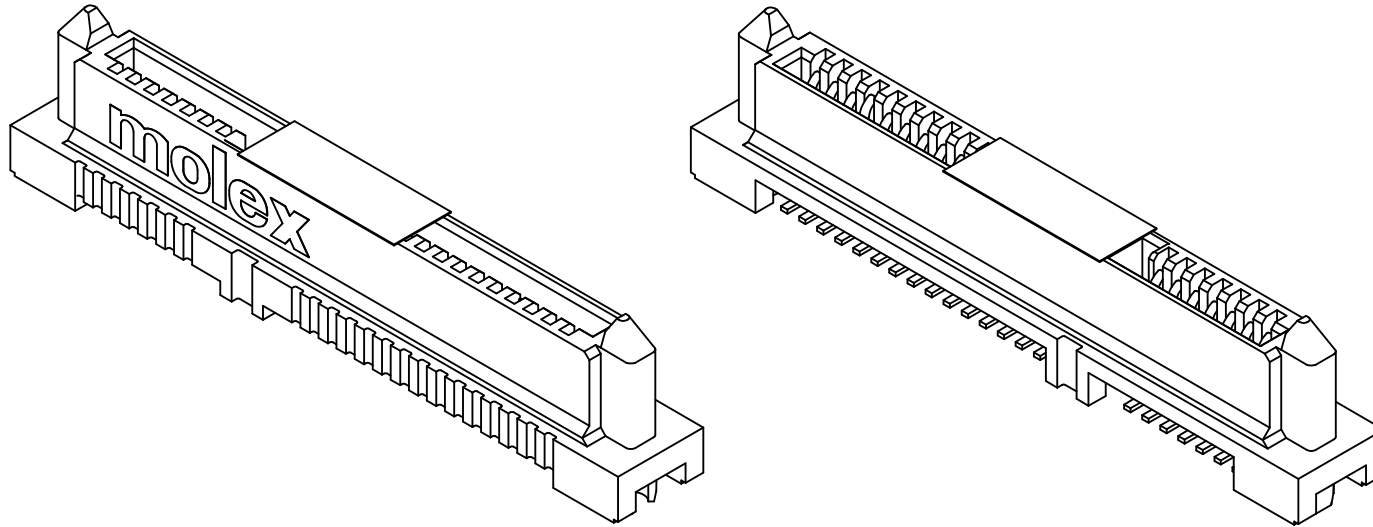

SHT5. UPDATE E/TAPE EC NO: S2012-0010 DRWN:ATSEE 2011/07/05 CHKD:SKANG 2011/07/11 APPR:MLONG 2011/07/11	DESCRIPTION REV	QUALITY SYMBOLS	GENERAL TOLERANCES (UNLESS SPECIFIED)		DIMENSION STYLE MM ONLY		SCALE NTS	DESIGN UNITS METRIC	THIRD ANGLE PROJECTION																									
		$\nabla_A = 0$ $\nabla_C = 0$ $\nabla_P = 0$	<table border="1"> <tr> <td></td> <td>mm</td> <td>INCH</td> </tr> <tr> <td>4 PLACES</td> <td>± ---</td> <td>± ---</td> </tr> <tr> <td>3 PLACES</td> <td>± ---</td> <td>± ---</td> </tr> <tr> <td>2 PLACES</td> <td>± 0.20</td> <td>± ---</td> </tr> <tr> <td>1 PLACE</td> <td>± ---</td> <td>± ---</td> </tr> </table>		mm	INCH	4 PLACES	± ---	± ---	3 PLACES	± ---	± ---	2 PLACES	± 0.20	± ---	1 PLACE	± ---	± ---	<table border="1"> <tr> <td>DRAWN BY</td> <td>DATE</td> </tr> <tr> <td>KHLIM</td> <td>2005/03/07</td> </tr> <tr> <td>CHECKED BY</td> <td>DATE</td> </tr> <tr> <td>KCLING</td> <td>2005/04/14</td> </tr> <tr> <td>APPROVED BY</td> <td>DATE</td> </tr> <tr> <td>SKTOH</td> <td>2005/04/14</td> </tr> </table>	DRAWN BY	DATE	KHLIM	2005/03/07	CHECKED BY	DATE	KCLING	2005/04/14	APPROVED BY	DATE	SKTOH	2005/04/14	TITLE		SERIAL ATA BACKPLANE SIL WITH 1.05 PEGS STD HEIGHT, RECEPT., SMT MOLEX INCORPORATED SD-87713-029
			mm	INCH																														
		4 PLACES	± ---	± ---																														
3 PLACES	± ---	± ---																																
2 PLACES	± 0.20	± ---																																
1 PLACE	± ---	± ---																																
DRAWN BY	DATE																																	
KHLIM	2005/03/07																																	
CHECKED BY	DATE																																	
KCLING	2005/04/14																																	
APPROVED BY	DATE																																	
SKTOH	2005/04/14																																	
ANGULAR ± 3 °		MATERIAL NO.		DOCUMENT NO.																														
DRAFT WHERE APPLICABLE MUST REMAIN WITHIN DIMENSIONS		SEE TABLE		SHEET NO. 4 OF 5																														
SIZE A3		THIS DRAWING CONTAINS INFORMATION THAT IS PROPRIETARY TO MOLEX INCORPORATED AND SHOULD NOT BE USED WITHOUT WRITTEN PERMISSION																																

9 8 7 6 5 4 3 2 1

TAPE AND REEL PACKAGING

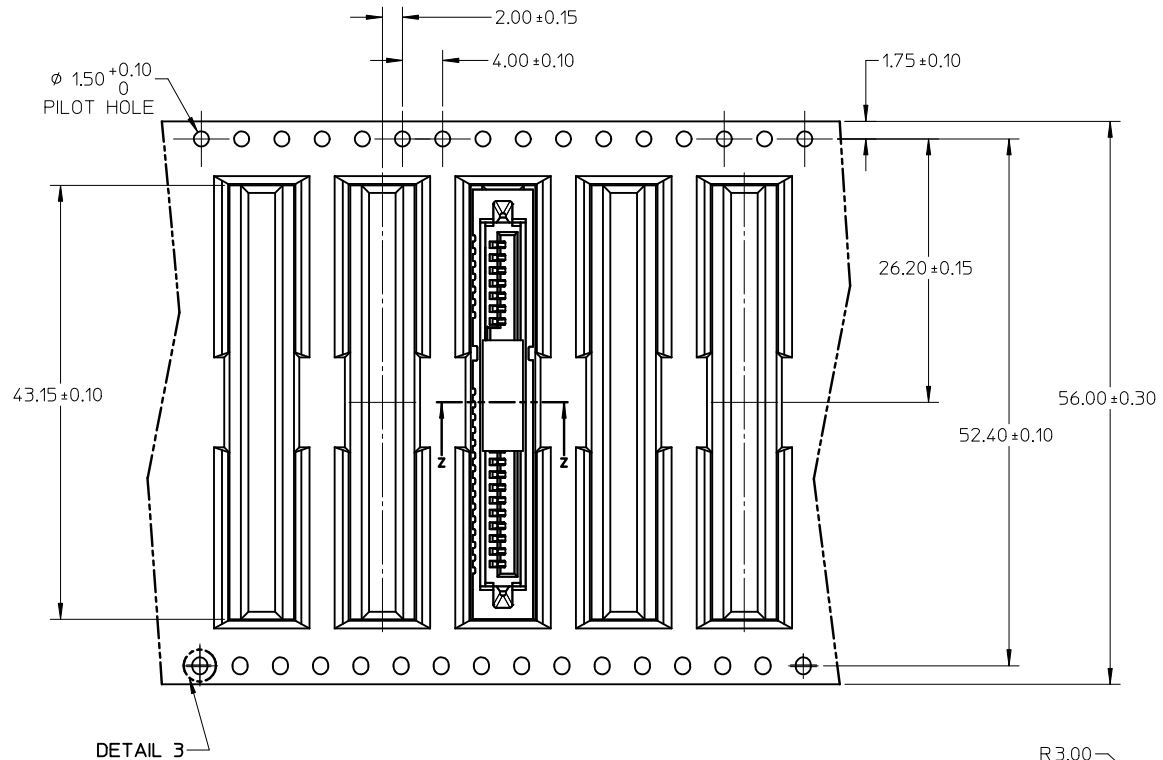

NOTES:

1. LEADER AND TRAILER TAPE

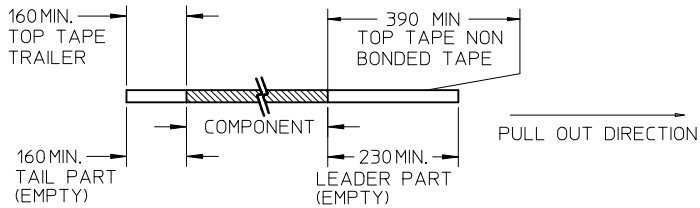

2. PEELING OFF FORCE OF THE TOP TAPE: 80gf MAX.
(PEELING DIRECTION AS SHOWN IN FOLLOWING FIGURE)

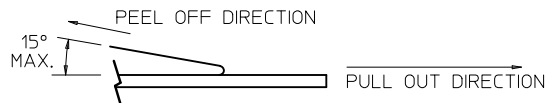

- 3. TAPE AND REEL SPECIFICATION IS AS PER EIA-481.
- 4. TAPE AND REEL QUANTITY : 400 PCS/ REEL.
- 5. THE TAPE IS TREATED FOR ANTI-STATIC.

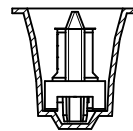

SECTION Z-Z

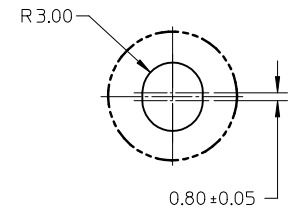

DETAIL 3

SHT5, UPDATE E/TAPE EC NO: S2012-0010 DRW:ATSEE CHK:D:SKANG APPR:MLONG 2011/07/05 2011/07/11 2011/07/11	DESCRIPTION REV	QUALITY SYMBOLS	GENERAL TOLERANCES (UNLESS SPECIFIED)		DIMENSION STYLE MM ONLY		SCALE NTS	DESIGN UNITS METRIC	THIRD ANGLE PROJECTION	
		$\nabla_{A'}=0$	mm	INCH	DRAWN BY KHLIM	DATE 2005/03/07	TITLE SERIAL ATA BACKPLANE SIL WITH 1.05 PEGS STD HEIGHT, RECEPT., SMT			
		$\nabla_{E'}=0$	4 PLACES ± --- ± ---	3 PLACES ± --- ± ---	CHECKED BY KCLING	DATE 2005/04/14	MOLEX INCORPORATED			
		$\nabla_{F'}=0$	2 PLACES ± 0.20 ± ---	1 PLACE ± --- ± ---	APPROVED BY SKTOH	DATE 2005/04/14	DOCUMENT NO. SD-87713-029			
		ANGULAR ± 3 °	DRAFT WHERE APPLICABLE MUST REMAIN WITHIN DIMENSIONS		MATERIAL NO. SEE TABLE		SHEET NO. 5 OF 5			
			THIS DRAWING CONTAINS INFORMATION THAT IS PROPRIETARY TO MOLEX INCORPORATED AND SHOULD NOT BE USED WITHOUT WRITTEN PERMISSION							