

KIT33978EKEVB and KIT34978EKEVB Evaluation Board

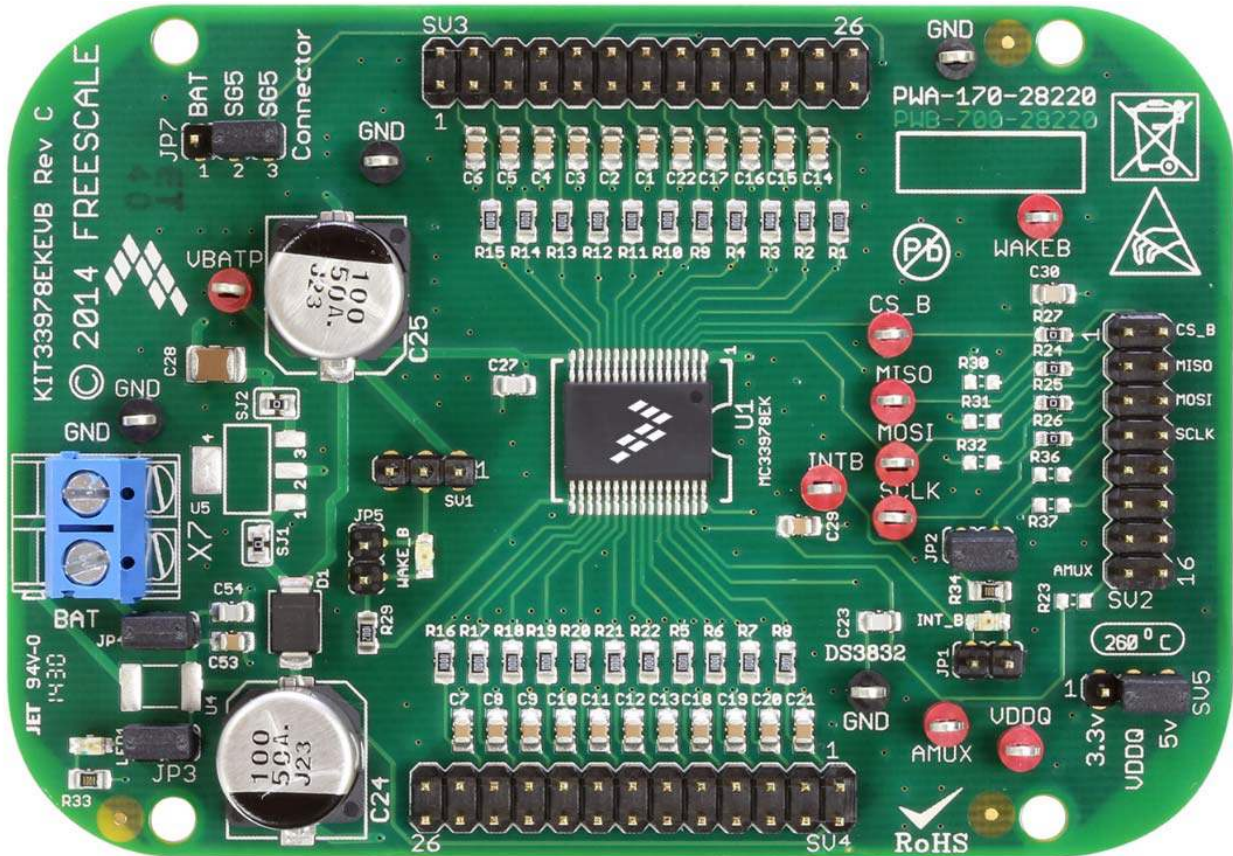

Figure 1. KIT33978EKEVB / KIT34978EKEVB



Contents

1 Important Notice	3
2 Getting Started	4
3 Getting to Know the Hardware	5
4 Accessory Interface Board	10
5 Installing the Software and Setting up the Hardware	11
6 Schematic	17
7 Board Layout	18
8 Bill of Materials	19
9 References	20
10 Revision History	21

1 Important Notice

Freescale provides the enclosed product(s) under the following conditions:

This evaluation kit is intended for use of ENGINEERING DEVELOPMENT OR EVALUATION PURPOSES ONLY. It is provided as a sample IC pre-soldered to a printed circuit board to make it easier to access inputs, outputs, and supply terminals. This evaluation board may be used with any development system or other source of I/O signals by simply connecting it to the host MCU or computer board via off-the-shelf cables. This evaluation board is not a Reference Design and is not intended to represent a final design recommendation for any particular application. Final device in an application will be heavily dependent on proper printed circuit board layout and heat sinking design as well as attention to supply filtering, transient suppression, and I/O signal quality.

The goods provided may not be complete in terms of required design, marketing, and or manufacturing related protective considerations, including product safety measures typically found in the end product incorporating the goods. Due to the open construction of the product, it is the user's responsibility to take any and all appropriate precautions with regard to electrostatic discharge. In order to minimize risks associated with the customers applications, adequate design and operating safeguards must be provided by the customer to minimize inherent or procedural hazards. For any safety concerns, contact Freescale sales and technical support services.

Should this evaluation kit not meet the specifications indicated in the kit, it may be returned within 30 days from the date of delivery and will be replaced by a new kit.

Freescale reserves the right to make changes without further notice to any products herein. Freescale makes no warranty, representation or guarantee regarding the suitability of its products for any particular purpose, nor does Freescale assume any liability arising out of the application or use of any product or circuit, and specifically disclaims any and all liability, including without limitation consequential or incidental damages. "Typical" parameters can and do vary in different applications and actual performance may vary over time. All operating parameters, including "Typical", must be validated for each customer application by customer's technical experts.

Freescale does not convey any license under its patent rights nor the rights of others. Freescale products are not designed, intended, or authorized for use as components in systems intended for surgical implant into the body, or other applications intended to support or sustain life, or for any other application in which the failure of the Freescale product could create a situation where personal injury or death may occur.

Should the Buyer purchase or use Freescale products for any such unintended or unauthorized application, the Buyer shall indemnify and hold Freescale and its officers, employees, subsidiaries, affiliates, and distributors harmless against all claims, costs, damages, and expenses, and reasonable attorney fees arising out of, directly or indirectly, any claim of personal injury or death associated with such unintended or unauthorized use, even if such claim alleges Freescale was negligent regarding the design or manufacture of the part. Freescale™ and the Freescale logo are trademarks of Freescale Semiconductor, Inc. All other product or service names are the property of their respective owners. © Freescale Semiconductor, Inc. 2015

2 Getting Started

2.1 Kit Contents/Packing List

The KIT33978EKEVB / KIT34978EKEVB contents include:

- Assembled and tested evaluation board/module in anti-static bag.
- Warranty card

2.2 Jump Start

Freescale's analog product development boards help to easily evaluate Freescale products. These tools support analog mixed signal and power solutions including monolithic ICs using proven high-volume SMARTMOS mixed signal technology, and system-in-package devices utilizing power, SMARTMOS and MCU dies. Freescale products enable longer battery life, smaller form factor, component count reduction, ease of design, lower system cost and improved performance in powering state of the art systems.

- Go to www.freescale.com/analogtools
- Locate your kit
- Review your Tool Summary Page
- Look for



- Download documents, software and other information

Once the files are downloaded, review the user guide in the bundle. The user guide includes setup instructions, BOM and schematics. Jump start bundles are available on each tool summary page with the most relevant and current information. The information includes everything needed for design.

2.3 Required Equipment and Software

To use this kit, you need:

- Power supply 12 V with at least 1.0 A current capability
- ON-OFF switch to Ground or Switch to Battery loads
- KITUSBSPIDGLEVME communication dongle
- SPIGen Graphic User Interface

2.4 System Requirements

The kit requires the following to function properly with the software:

- Windows® XP, Windows 7, or Vista in 32- and 64-bit versions

3 Getting to Know the Hardware

3.1 Board Overview

The KIT33978EKEVB and KIT34978EKEVB Evaluation Board (EVB) features the MC33978 / MC34978 - 22 Channel Switch Detection Interface with programmable wetting current. The kit is designed to detect the closing and opening of up to 22 switch contacts. The switch status, either open or closed, is transferred to the microprocessor unit (MCU) through a serial peripheral interface (SPI). The device also features a 24-to-1 analog multiplexer for reading inputs as analog.

The analog input signal is buffered and provided on the AMUX output pin to be read by an external MCU. The MC33978 / MC34978 device has two modes of operation, Normal and Sleep. Normal Mode allows programming of the device and supplies switch contacts with pull-up or pull-down current as it monitors switch change-of-state, while the sleep mode provide switch status detection with maximum power saving.

The KIT33978EKEVB / KIT34978EKEVB can be controlled through a USB/SPI dongle (KITUSBSPIDGLEVME) connected to the PC's USB port. The Freescale SPIGen (version 7.0 and above) program provides the user interface to the MC33978 / MC34978 SPI port and allows the user to program the configuration Registers, send commands to the IC and receive status from the IC.

3.2 Board Features

The board features are as follows:

- MC33978 / MC34978 device with 22 channels switch detection and status report capability
- An onboard 16-pin interface connector for the Freescale SPI-to-USB Interface Dongle (KITUSBSPIDGLEVME)
- Status LEDs to report the status of the MC33978 and MC34978 Interrupt (INT) and Wake-Up lines
- Double row, 100mils SGx/SPx pin connectors for easy interface with external loads
- Direct connection to Batter power with optional 5.0 V/3.3 V LDO for VDDQ rail supply

3.3 Board Description

The KIT33978EKEVB / KIT34978EKEVB is divided in three main sections as shown in Figure 2.

- Input Power supply
- Switch detection Interface
- SPI communication interface

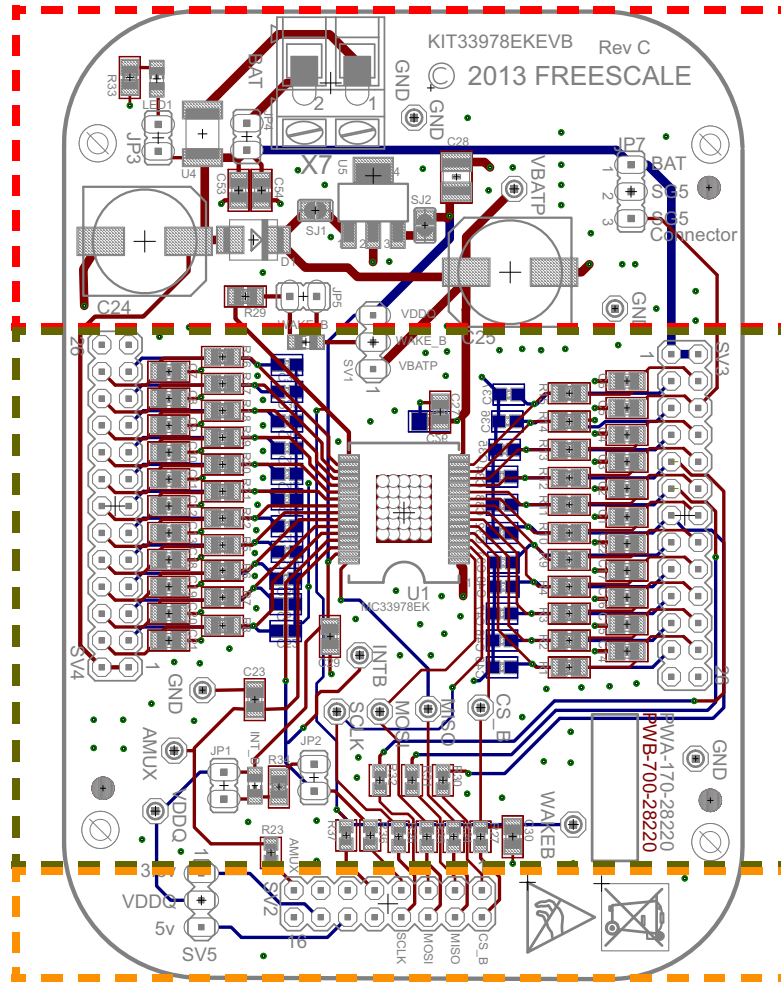

Figure 2. KIT33978EKEVB / KIT34978EKEVB Board Description

Table 1. Board Description

Name	Description
Input Power supply	The input power supply provides direct connection to battery voltage which serve as the source for VBATP supply for the MC33978 / MC34978 and all other configurations that may required to be connected to this voltage rail. It also provide the footprint for an optional LDO regulator to generate VDDQ supply internally out of the battery voltage.
Switch Detection Interface	The switch detection interface include the MC33978 / MC34978 device itself, as well as the configuration jumpers, and test points to provide easy access to all pins on this device. It also provide 2 I/O connectors (SV3 and SV4) to provide direct access to the SG and SP pins.
SPI communication interface	The SPI communication interface includes a 16-pin header prepared to interface with the SPI Dongle (KITUSBSPIDGLEVME).

3.4 LED Display

The following LEDs are provided as visual indicators for the KIT33978EKEVB / KIT34978EKEVB evaluation board:

1. LED1: When JP3 is shorted, LED1 indicates the presence of battery voltage on connector X7.
2. WAKE_B LED: When external pull-up is selected on SV1, the LED lights when the device is in Normal mode.
3. INT_B LED: When JP2 is shorted, the LED lights up when an interrupt even has occurred. LED turns off when the INTflg is cleared.

3.5 Connectors

The KIT33978EKEVB and KIT34978EKEVB provides various connectors to supply power, interface with programming logic or interface with the switch loads.

Table 2. Connectors

Name	Type	Description		
X7	Supply	Battery supply connector		
SV2	I/O interface (SPI Dongle)	SPI dongle interface connector Note: Pins are mirrored compared to the connector on the SPI dongle board. Use a straight through flat ribbon cable to interface with the KIT33978EKEVB and KIT34978EKEVB. <table border="1" style="width: 100%; border-collapse: collapse;"> <tr> <td style="width: 50%; vertical-align: top;"> PIN1 = SG1 PIN3 = SG2 PIN5 = SG3I PIN7 = INT_B PIN9 = WAKE_B PIN11 = Unused PIN13 = Unused PIN15 = AMUX </td> <td style="width: 50%; vertical-align: top;"> PIN2 = CS_B PIN4 = MISO PIN6 = MOSI PIN8 = SCLK PIN10 = UNUSED PIN12 = SPI Dongle 5.0 V PIN14 = SPI Dongle 3.3 V PIN16 = AGND </td> </tr> </table>	PIN1 = SG1 PIN3 = SG2 PIN5 = SG3I PIN7 = INT_B PIN9 = WAKE_B PIN11 = Unused PIN13 = Unused PIN15 = AMUX	PIN2 = CS_B PIN4 = MISO PIN6 = MOSI PIN8 = SCLK PIN10 = UNUSED PIN12 = SPI Dongle 5.0 V PIN14 = SPI Dongle 3.3 V PIN16 = AGND
PIN1 = SG1 PIN3 = SG2 PIN5 = SG3I PIN7 = INT_B PIN9 = WAKE_B PIN11 = Unused PIN13 = Unused PIN15 = AMUX	PIN2 = CS_B PIN4 = MISO PIN6 = MOSI PIN8 = SCLK PIN10 = UNUSED PIN12 = SPI Dongle 5.0 V PIN14 = SPI Dongle 3.3 V PIN16 = AGND			
SV3	I/O interface	Switch detect channel interface connector (Odd pins connect directly to MC33978 / MC34978 pin, even pins connect to the same node through a 100 Ω resistor.) Pin 1 and 2 = BATTERY voltage Pin 3 = SG6 --> 100 ohm --> Pin 4 = SG6R Pin 5 = SG5 --> 100 ohm --> Pin 6 = SG5R Pin 7 = SG4 --> 100 ohm --> Pin 8 = SG4R Pin 9 = SG3 --> 100 ohm --> Pin 10 = SG3R Pin 11 = SG2 --> 100 ohm --> Pin 12 = SG2R Pin 13 = SG1 --> 100 ohm --> Pin 14 = SG1R Pin 15 = SG0 --> 100 ohm --> Pin 16 = SG0R Pin 17 = SP3 --> 100 ohm --> Pin 18 = SP3R Pin 19 = SP2 --> 100 ohm --> Pin 20 = SP2R Pin 21 = SP1 --> 100 ohm --> Pin 22 = SP1R Pin 23 = SP0 --> 100 ohm --> Pin 24 = SP0R Pin 25 and 26 = GND		
SV4	I/O interface	Switch detect channel interface connector (Odd pins connect directly to MC33978 / MC34978 pin, even pins connect to the same node through a 100 Ω resistor.) Pin 1 and 2 = BATTERY voltage Pin 3 = SP7 --> 100 ohm --> Pin 4 = SP7R Pin 5 = SP6 --> 100 ohm --> Pin 6 = SP6R Pin 7 = SP5 --> 100 ohm --> Pin 8 = SP5R Pin 9 = SP4 --> 100 ohm --> Pin 10 = SP4R Pin 11 = SG13 --> 100 ohm --> Pin 12 = SG13R Pin 13 = SG12 --> 100 ohm --> Pin 14 = SG12R Pin 15 = SG11 --> 100 ohm --> Pin 16 = SG11R Pin 17 = SG10 --> 100 ohm --> Pin 18 = SG10R Pin 19 = SG9 --> 100 ohm --> Pin 20 = SG9R Pin 21 = SG8 --> 100 ohm --> Pin 22 = SG8R Pin 23 = SG7 --> 100 ohm --> Pin 24 = SG7R Pin 25 and 26 = GND		

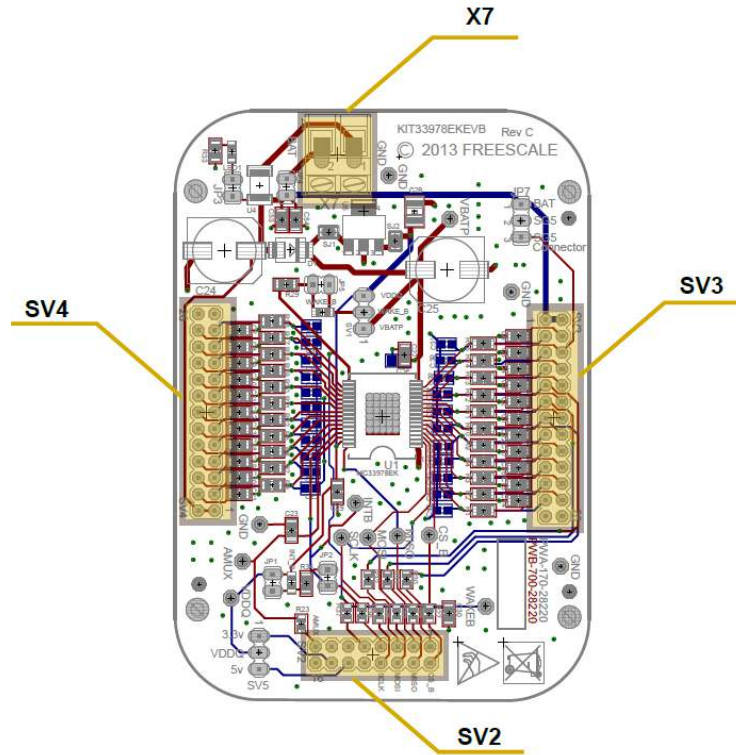

Figure 3. Connector Locations

3.6 Test Point Definitions

The following test points provide access to signals on the MC33978 and MC34978 IC.

Table 3. Test Point Definitions

Schematic Label	Description
VBATP	Supply Voltage
VDDQ	Logic Supply Voltage
INTB	I/O Interrupt pin
WAKEB	I/O Wake up pin
AMUX	Analog Multiplexer output pin
SCLK	SPI serial Clock
MOSI	SPI Master out - Slave in
MISO	SPI Master In - Slave Out
CS_B	SPI Chip select
GND	4 x ground reference

3.7 Jumper Definitions

The following table defines the evaluation board jumper positions and explains their functions.

Table 4. Jumper Definition

Name	Default	Description
JP1	Open	INT_B LED Bypass jumper (short to bypass LED)
JP2	Close	INT_B external pull-up enable. (short to enable the External pull-up to VDDQ)
JP3	Close	Battery Voltage LED. Short to enable LED indicator when Battery is connected on X7
JP4	Close	Battery supply jumper. Short to allow voltage on X7 to supply the KIT33978EKEVB and KIT34978EKEVB board
JP5	Open	WAKE_B LEDE bypass jumper. (short to bypass the LED)
JP7	2-3	SG5 input selector. Short position 1-2 to connect SG5 to Battery voltage Short position 2-3 to allow SG5 input from connector SV3
SV1	1-2	WAKE_B pull up selector Short position 1-2 to select VBATP as pull-up voltage Short position 2-3 to select VDDQ as pull-up voltage
SV5	2-3	VDDQ supply selector from SPI dongle connector Short position 1-2 for 3.3 V VDDQ supply Short position 2-3 for 5.0 V VDDQ supply

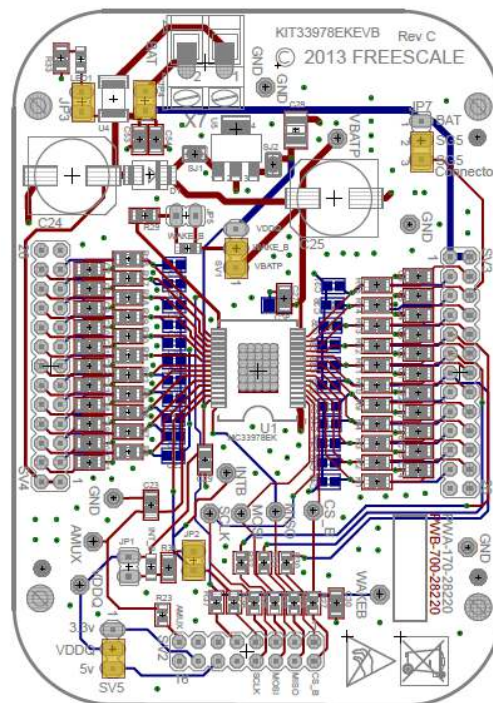

Figure 4. Default Jumper Configuration

4 Accessory Interface Board

The KIT33978EKEVB and KIT34978EKEVB may be used with the KITUSBSPIDGLEVME interface dongle, which provides a USB-to-SPI interface. This small board makes use of the USB, SPI and parallel ports built into Freescale's MC68HC908JW32 microcontroller. The main function provided by this dongle is to allow Freescale evaluation kits having a parallel port to communicate via a USB port to a PC.



Figure 5. KITUSBSPIDGLEVME Interface Dongle

4.1 Connecting the KITUSBSPIDGLEVME Interface Dongle

A typical connection of KITUSBSPIDGLEVME Interface Dongle to the KIT33978EKEVB and KIT34978EKEVB evaluation board is done through a straight through flat ribbon cable from the IO PORT connector on the SPI Dongle to connector SV2 on the KIT33978EKEVB and KIT34978EKEVB board.

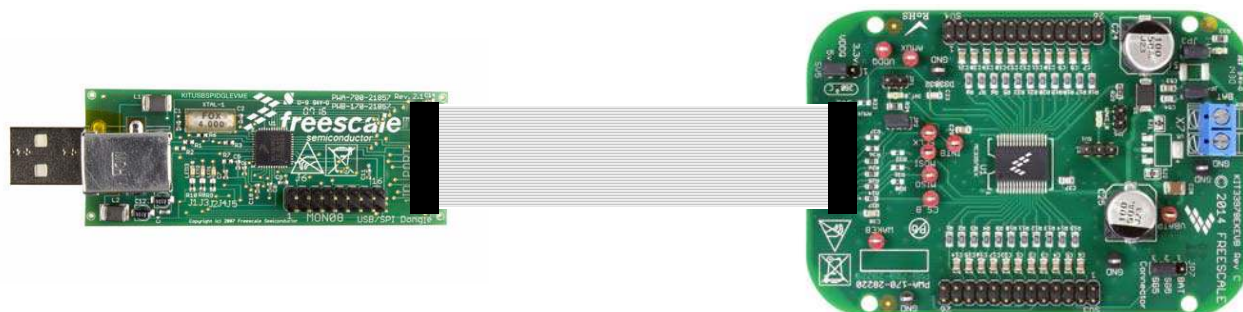

Figure 6. Connecting KITUSBSPIDGLEVME to the Evaluation Board

Table 5. KITUSBSPIDGLEVME I/O Port plus KIT33978EKEVB / KIT34978EKEVB SV2 Pin Definitions

KIT33978EKEVB and KIT34978EKEVB		KITUSBSPIDGLEVME		
Pin Number	Name	Pin Number	Name	Description
2	CS_B	1	CSB	SPI signal, Chip Select Bar
1	SG1	2	CNTL2	CNTL2 connected to SG1
4	MISO	3	SO	SPI signal, Serial Out
3	SG2	4	CNTL1	CNTL1 connected to SG2
6	MOSI	5	SI	SPI signal, Serial In
5	SG3	6	CNTL0	CNTL0 connected to SG3
8	SCLK	7	SCLK	SPI signal, Serial Clock
7	INT_B	8	DATA4	DATA4 connected to INT_B
10	UNUSED	9	CNTL3	NC
9	WAKE_B	10	DATA3	DATA3 connected to WAKE_B
12	5V	11	VDD	+5.0 Volt VDD from USB
11	UNUSED	12	DATA2	NC
14	3.3V	13	+3.3 V	+3.3 V from USB
13	UNUSED	14	DATA1	NC
16	GND	15	GND	Signal Ground
15	AMUX	16	DATA0	DATA0 connected to AMUX

5 Installing the Software and Setting up the Hardware

5.1 Installing SPIGen Freeware on your Computer

The latest version of SPIGen is designed to run on any Windows 8, Windows 7, Vista, or XP-based operating system. To install the software, go to www.freescale.com/analogtools and select your kit. Click on the link to open the corresponding Tool Summary Page. Look for “Jump Start Your Design”. Download to your computer desktop the SPIGen software. Run the install program from the desktop. The Installation Wizard guides you through the rest of the process.

To use SPIGen, go to the Windows Start menu, then Programs, then SPIGen, and click on the SPIGen icon. The SPIGen Graphic User Interface (GUI) appears. The GUI provide embedded support for some Freescale devices, eliminating the need of loading a configuration file to talk to an specific device. The MC33978 / MC34978 is already supported by the latest SPIGen software. Locate the MC33978 / MC34978 folder from the “Device View” window, and click on it to expand and get access to all the configuration registers for the MC33978 / MC34978 device.

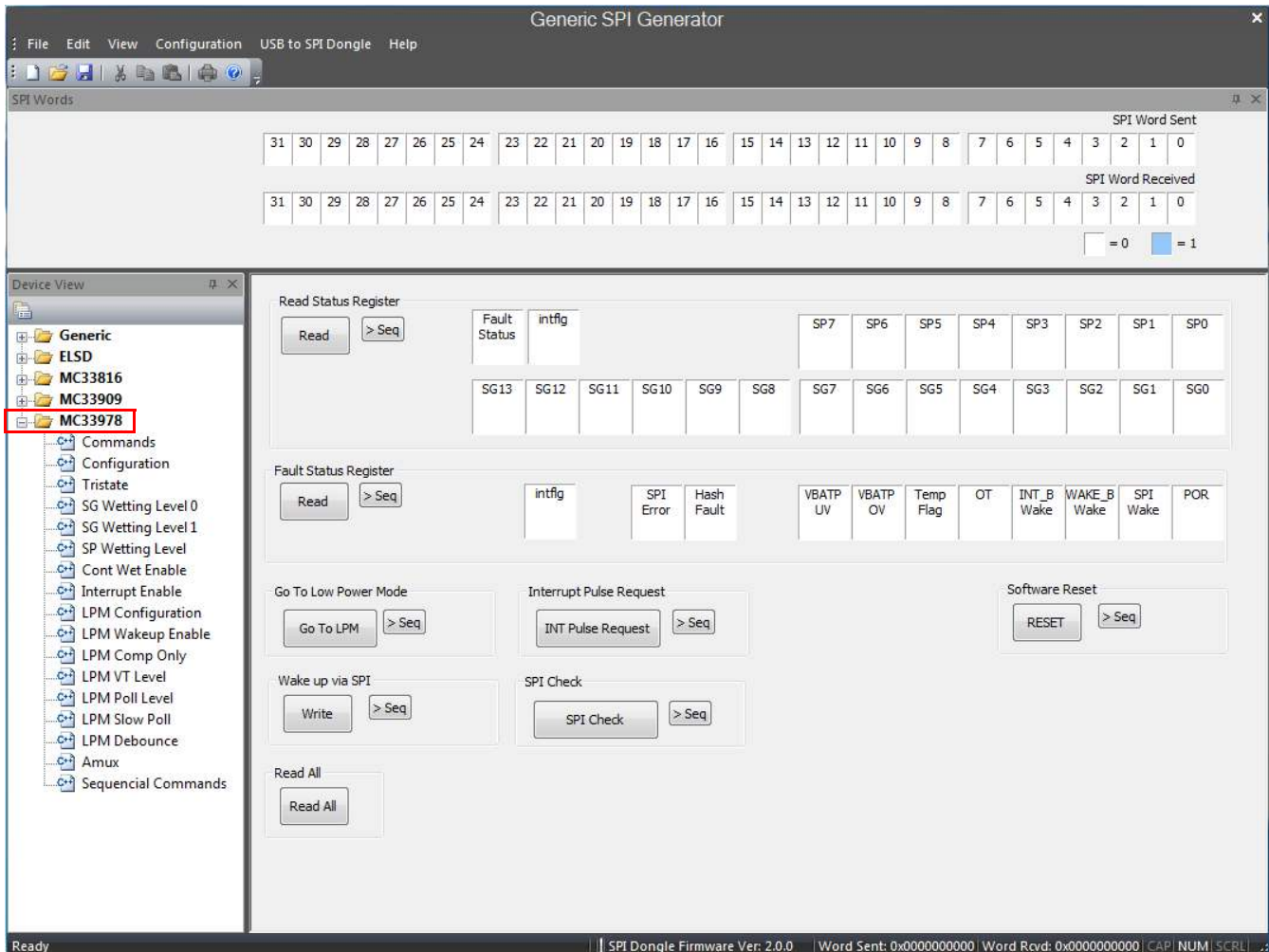

Figure 7. SPIGen GUI

5.2 Describing the GUI Interface

The SPIGen GUI is divided into three major sections:

1. Device View: provide a list of supported devices embedded into the SPIGen software.
2. Command window: provide access to all the functions and commands contained in each one of the command pages for the MC33978 / MC34978.
3. SPI Words window: provide the latest SPI word sent and received in RAW format (32 bits).

5.3 Using the GUI Interface

Before starting the communication with the KIT33978EKEVB / KIT34978EKEVB, it is important to understand the Full Duplex nature of the SPI communication protocol.

During each SPI clock cycle, a full duplex data transmission occurs:

- the master sends a bit on the MOSI line; the slave reads it from that same line
- the slave sends a bit on the MISO line; the master reads it from that same line

Not all transmissions require all four of these operations to be meaningful, but they do happen.

This means that when the master sends a configuration command [A] through the MOSI pin, the actual data received on the MISO pin is the value for the transaction made in the previous SPI request, which in turns means that the user sees the result to the command [A] on the MISO response of the next SPI transaction [B] as depicted in [Figure 8](#).

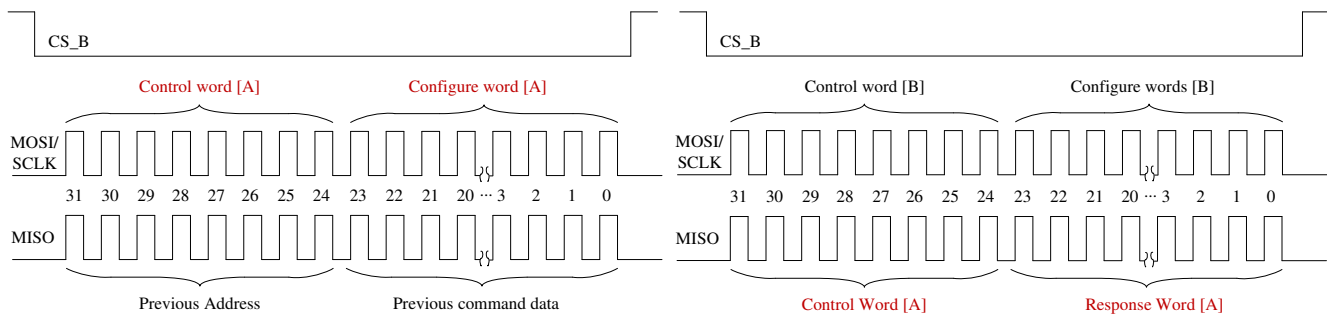

Figure 8. Full Duplex SPI transaction example.

Due to the Full Duplex nature of the protocol, when using the SPIGen GUI, the user should send the command twice in order to see the actual response to the request sent.

5.3.1 Reading/Writing a SPI register

The MC33978 and MC34978 SPI register map is formed by 30 Functional registers that can be Read only, Write only or Read and Write. For more detail on the organization and register definition, refer to the MC33978 / MC34978 Data Sheet. The SPIGen GUI provides a friendly way to configure and read each one of the registers.

To write a configuration register / command:

- Click on the corresponding command page
- Highlight the Register bits to set the register to 1 or clear to set to 0 or select the pre-defined configuration options if available.
- Click the “Write” button to send the SPI command

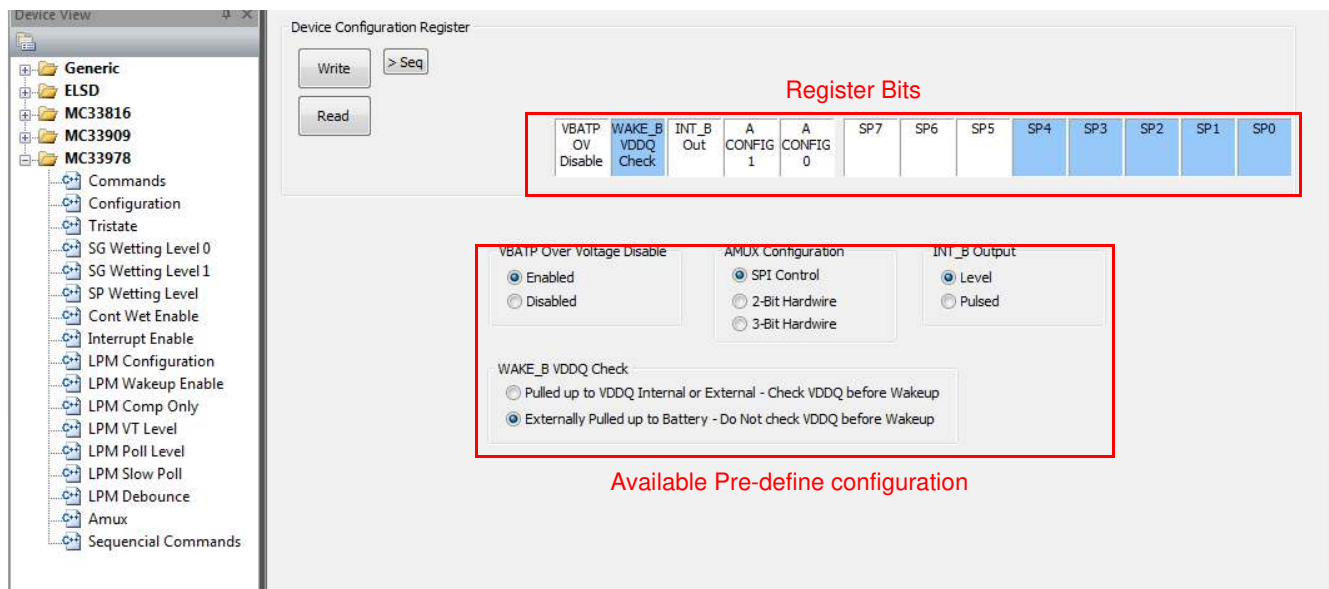

Figure 9. Register SPI Write

To read the value of a specific register, click the “Read” button twice, and the current value is populated on the Raw Register bits. The SPIGen GUI allows to write or read on registers according to its proper function, therefore, if a register is Read only, SPIGen does not provide a predefined way to write into that register. Figure 10 shows the Read Status Register, which is an example of a read only register on the MC33978 and MC34978, therefore SPIGen provides only the “Read” button.

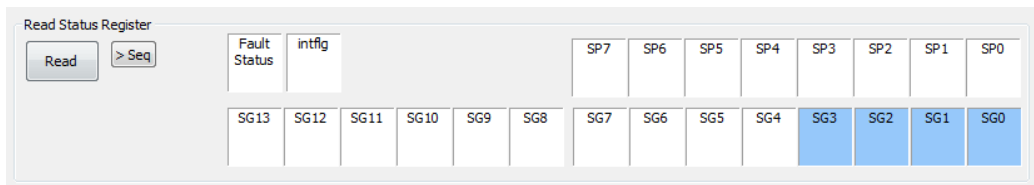

Figure 10. Read only Register example

5.3.2 Creating Sequential Scripts

The SPIGen GUI provides a way to create, save, and load scripts with a sequence of commands for quick configuration. To add commands to the “sequential command” page, set the configuration bits as desired and click on the “>Seq” button. The corresponding configuration is added to the “Sequential commands” in the order they are entered as shown in [Figure 11](#).

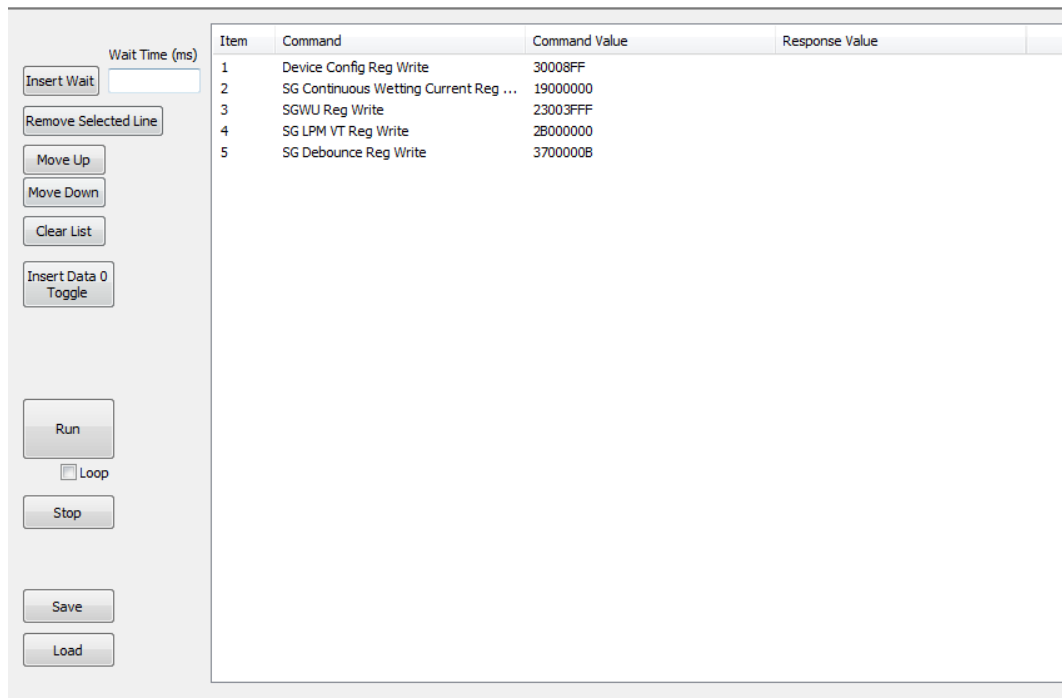

Figure 11. Sequential Command Page

The sequential script page allows to organize and create various functions within the script by using the following buttons.

- Insert Wait: Insert a defined delay before the next command.
- Remove Selected line: Delete the selected line from the script.
- Move Up/Down: Shift the selected command one place up or down.
- Clear List: Delete all lines from the script window.
- Insert Data 0 Toggle: Not Used on KIT33978EKEVB / KIT34978EKEVB
- Run: Start the script run as a single or loop sequence.
- Loop: Enable the looping sequence mode to repeat the script indefinitely.
- Stop: Stops the script before it is over.
- Save: save the current configuration into a .txt file.
- Load: load a previous configuration from a file.

5.3.3 Sending Customize SPI commands

The SPIGen GUI allows the sending of customized 32-bit SPI words for debugging or any other special use with the MC33978 and MC34978.

- From Generic folder in the Device View, select the Single command page.
- Chose the 32-bit length and chose the format preference. (binary or Hex)
- Set the bits high or low as desired.
- Click the “Send Once” or “Send Continuously” button to send the selected word through SPI.

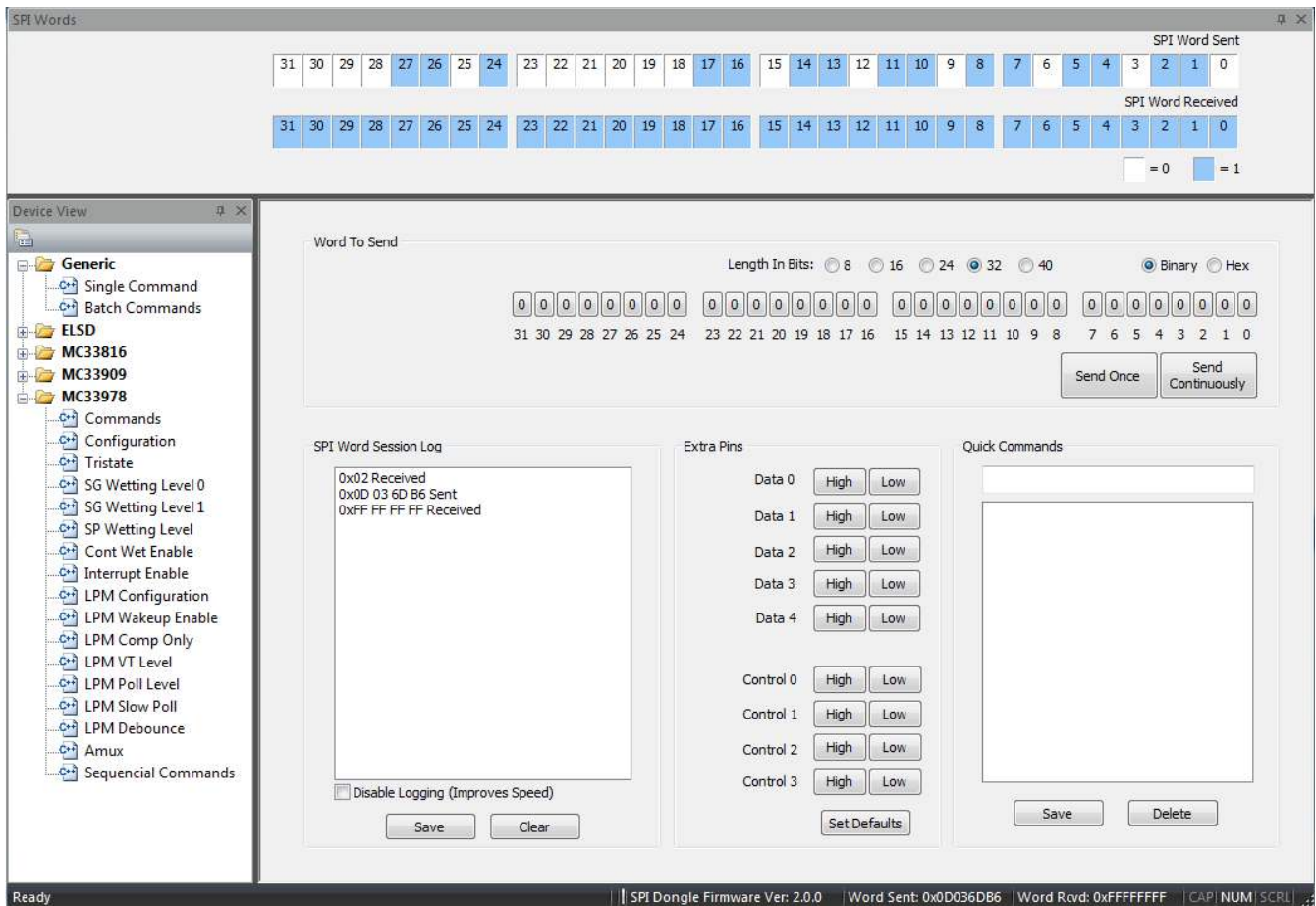

Figure 12. Generic Single command Page

The “SPI word Session Log” frame, shows the history of commands sent.

The “Extra pins” section allows to set high or low the extra control/data I/Os provided in the IO Port of the KITUSBSPIDGLEVME. Refer to [Table 5](#) for the pin to pin correlation between the interface connector on both KITUSBSPIDGLEVME and KIT33978EKEVB / KIT34978EKEVB boards. Note that not all signals may be usable as input or output with the KIT33978EKEVB and KIT34978EKEVB. Make sure you understand each pin function on the MC33978 / MC34978 before applying a high or low to these pins.

Finally, the “Quick Commands” section allow the user to create customized commands and the commands are saved for further quick access during the current session. To save a quick command, set the 32-bit word you want to save, write a name on the header frame, and then click the “Save” button. The new commands added are listed below the header frame.

5.4 Configuring the Hardware

Figure 13 shows the configuration diagram for the KIT33978EKEVB / KIT34978EKEVB.

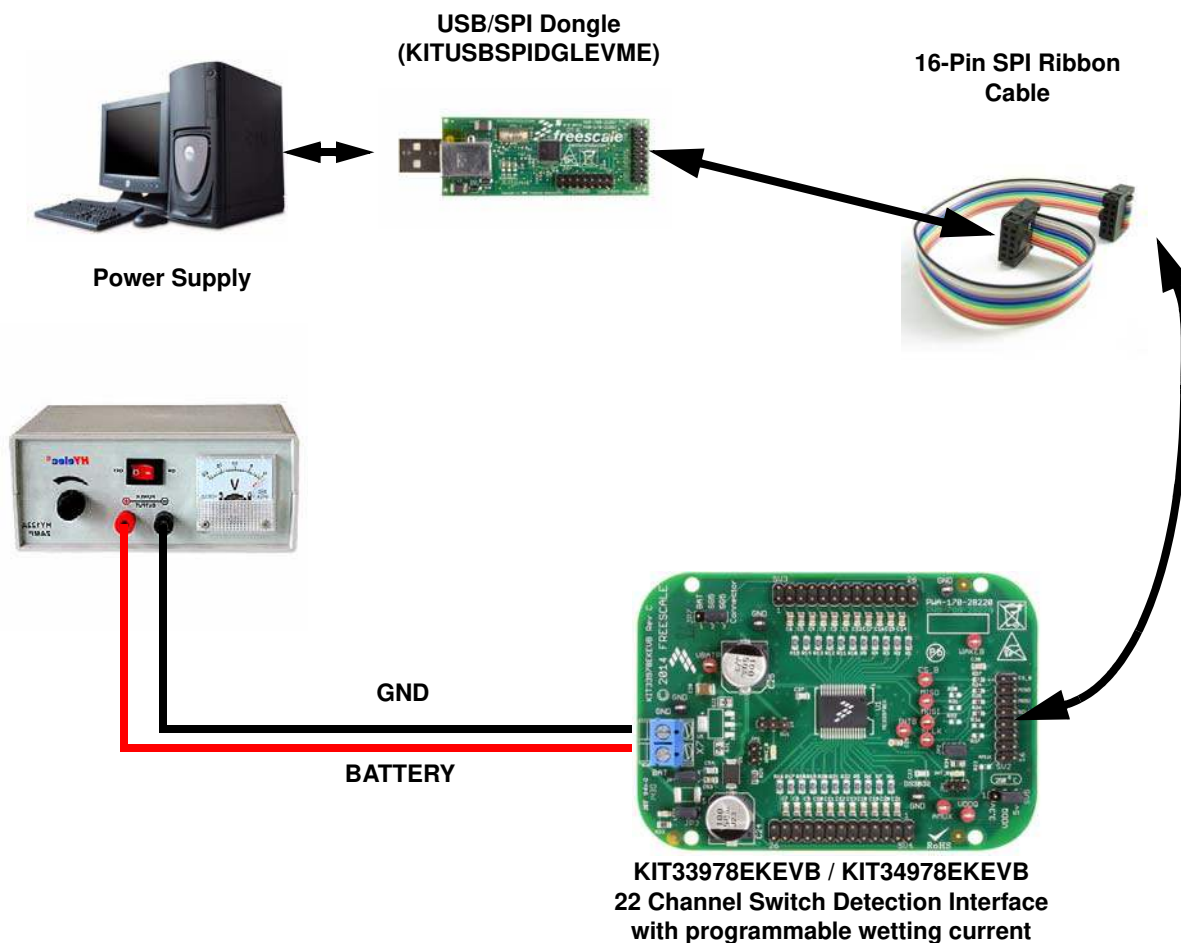

Figure 13. KIT33978EKEVB / KIT34978EKEVB plus KITUSBSPIDGLEVME Board Setup

5.4.1 Step-by-step Instructions for Setting up the Hardware using SPIGen

To start working with the KIT33978EKEVB / KIT34978EKEVB, the following connections and setup must be performed:

1. Install the SPIGen.
2. Connect KITUSBSPIDGLEVME to the computer and to the KIT33978EKEVB / KIT34978EKEVB evaluation board.
3. Attach DC power supply (without turning on the power) to KIT33978EKEVB / KIT34978EKEVB.
4. Attach loads to the KIT33978EKEVB / KIT34978EKEVB board output terminals as desired.
5. Launch SPIGen and select the MC33978 command page.
6. Turn on the power supply. LED1 lights up.
7. Send a command on the SPIGen software and make sure you get a valid response on the SPI Word Received.
8. Go to the Tri-state page and clear all SG/SP bits.
9. If switch load to ground/battery are attached, change the status of the switches and read the status register to verify whether the MC33978 / MC34978 is detecting the switch status change.
 - When a change of status is detected on a channel, the INT_B LED should light up. The LED turns off when the status register is read.

6 Schematic

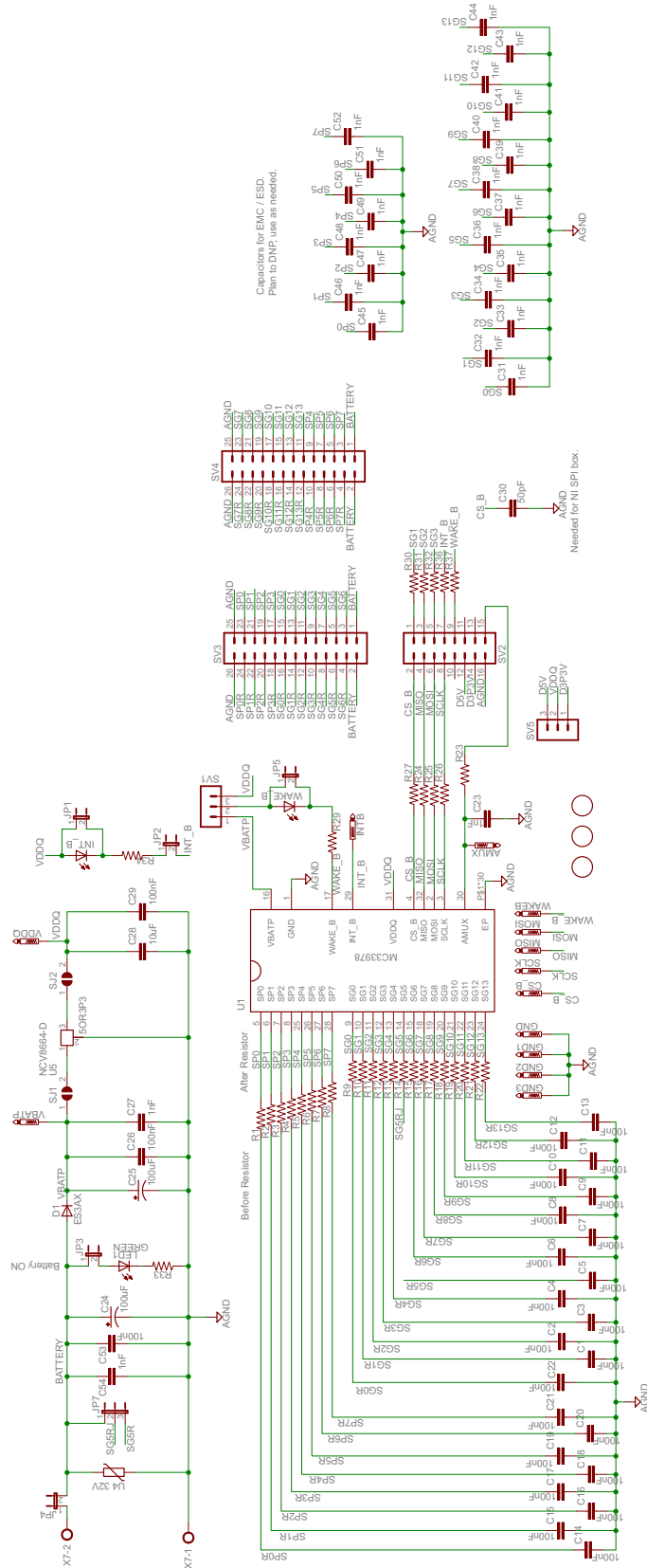

Figure 14. Evaluation Board Schematic

7 Board Layout

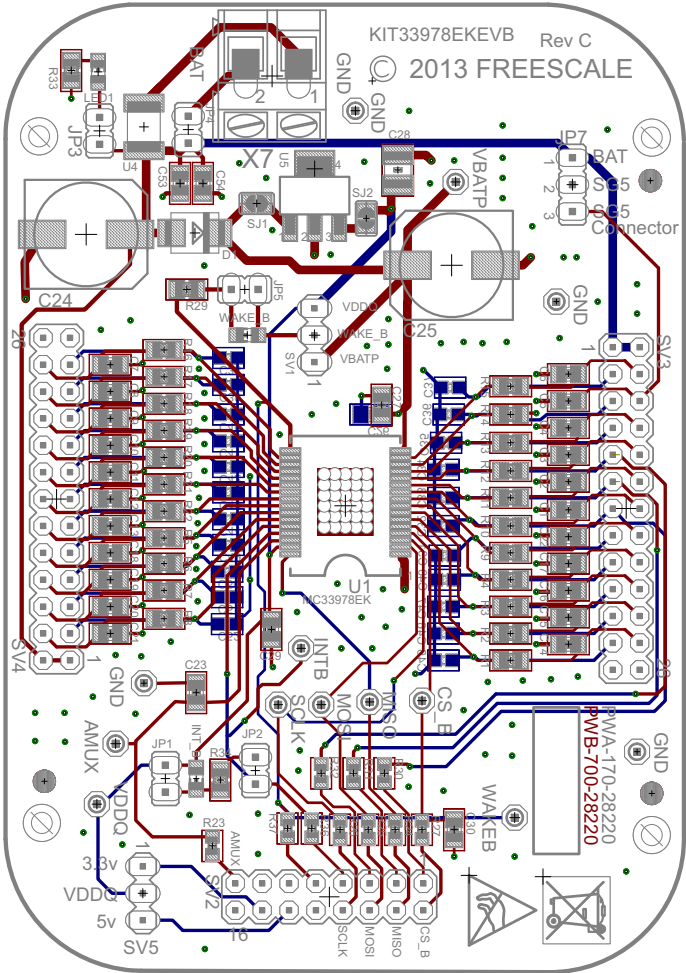

Figure 15. Evaluation Board Layout

8 Bill of Materials

Table 6. Bill of Materials ⁽¹⁾

Item	Qty	Schematic Label	Value	Description	Part Number	Assy Opt
Active Components						
1	1	U1	-	22 Channel Switch Detection Interface SOIC32	MC33978EK/ MC34978EK	(2)
2	1	U4	32 V	Varistor	CN1812	(3)
3	1	U5	-	3.3 V or 5.0 V LDO - SOT223	NCV8664	(3)
Diodes						
4	1	D1	-	RECTIFIER, FAST, 3 A, 50 V, DO-214AB, Diode	ES3A	
5	1	LED1	-	0805 Green LED		
6	2	INT_B, WAKE_B	-	0805 Red LED		
Capacitors						
7	25	C1, C2, C3, C4, C5, C6, C7, C8, C9, C10, C11, C12, C13, C14, C15, C16, C17, C18, C19, C20, C21, C22, C26, C29, C53	100 nF	0805 100 nF capacitor 50 V		
8	2	C24, C25	100 uF	Electrolythic capacitor Radial		
9	1	C28	10 uF	1210 10 uF capacitor 10 V		
10	22	C31, C32, C33, C34, C35, C36, C37, C38, C39, C40, C41, C42, C43, C44, C45, C46, C47, C48, C49, C50, C51, C52	1 nF	0603 1 nF capacitor		(3)
11	3	C23, C27, C54	1 nF	0805 1 nF capacitor		
12	1	C30	50 pF	0805 50 pF capacitor		
Resistors						
13	2	SJ1, SJ2	0 Ω	0805 0 Ω shunt resistor		
14	4	R24, R25, R26, R27,	0 Ω	0603 0 Ω resistor		
15	6	R23, R30, R31, R32, R37, R36	0 Ω	0603 0 Ω resistor		(3)
16	1	R29	10 KΩ	0805 10 KΩ Resistor		
17	2	R33, R34	1.0 KΩ	0805 1 KΩ resistor		
18	22	R1, R2, R3, R4, R5, R6, R7, R8, R9, R10, R11, R12, R13, R14, R15, R16, R17, R18, R19, R20, R21, R22	50 Ω	0805 50 Ω resistor		
Switches, Connectors, Jumpers and Test Points						
19	1	X7	-	Terminal block 5mm 2 POS		
20	5	JP1, JP2, JP3, JP4, JP5	-	1x2 100mils header		
21	3	JP7, SV1, SV5	-	1x3 100 mils header		
22	1	SV2	-	2x8 100 mils header		
23	2	SV3, SV4	-	2x13 100 mils header		
24	13	AMUX, CS_B, GND, GND1, GND2, GND3, INTB, MISO, MOSI, SCLK, VBATP, VDDQ, WAKEB		Test Points		

Notes

1. Freescale does not assume liability, endorse, or warrant components from external manufacturers are referenced in circuit drawings or tables. While Freescale offers component recommendations in this configuration, it is the customer's responsibility to validate their application.
2. **Critical components.** For critical components, it is vital to use the manufacturer listed.
3. Do not populate

9 References

Following are URLs where you can obtain information on related Freescale products and application solutions:

Freescale.com Support Pages	Description	URL
KIT33978EKEVB	Tool Summary Page	http://www.freescale.com/webapp/sps/site/prod_summary.jsp?code=KIT33978EKEVB
MC33978	Product Summary Page	http://www.freescale.com/webapp/sps/site/prod_summary.jsp?code=MC33978
KIT34978EKEVB	Tool Summary Page	http://www.freescale.com/webapp/sps/site/prod_summary.jsp?code=KIT34978EKEVB
MC34978	Product Summary Page	http://www.freescale.com/webapp/sps/site/prod_summary.jsp?code=MC34978
KITUSBSPIDGLEVME	Tool Summary Page	http://www.freescale.com/webapp/sps/site/prod_summary.jsp?code=KITUSBSPIDGLEVME
SPIGen	Software	http://www.freescale.com/webapp/sps/site/prod_summary.jsp?code=SPIGEN

9.1 Support

Visit www.freescale.com/support for a list of phone numbers within your region.

9.2 Warranty

Visit www.freescale.com/warranty for a list of phone numbers within your region.

10 Revision History

Revision	Date	Description of Changes
1.0	12/2014	<ul style="list-style-type: none"> • Initial Release
2.0	1/2015	<ul style="list-style-type: none"> • Adding support for KIT34978EKEVB evaluation board

How to Reach Us:

Home Page:
freescale.com

Web Support:
freescale.com/support

Information in this document is provided solely to enable system and software implementers to use Freescale products. There are no express or implied copyright licenses granted hereunder to design or fabricate any integrated circuits based on the information in this document.

Freescale reserves the right to make changes without further notice to any products herein. Freescale makes no warranty, representation, or guarantee regarding the suitability of its products for any particular purpose, nor does Freescale assume any liability arising out of the application or use of any product or circuit, and specifically disclaims any and all liability, including without limitation consequential or incidental damages. "Typical" parameters that may be provided in Freescale data sheets and/or specifications can and do vary in different applications, and actual performance may vary over time. All operating parameters, including "typicals," must be validated for each customer application by customer's technical experts. Freescale does not convey any license under its patent rights nor the rights of others. Freescale sells products pursuant to standard terms and conditions of sale, which can be found at the following address: freescale.com/SalesTermsandConditions.

Freescale and the Freescale logo are trademarks of Freescale Semiconductor, Inc., Reg. U.S. Pat. & Tm. Off. SMARTMOS is a trademark of Freescale Semiconductor, Inc. All other product or service names are the property of their respective owners.

© 2015 Freescale Semiconductor, Inc.

Document Number: KT33978UG
Rev. 2.0
1/2015