

REVISION

A	TB	D Cheung
6/19/2003	ECN-26615	
RELEASE FOR PRODUCTION		
B	TW	E MINGS
11/29/2004	ECN-41176	
ADD NOTE 8, UPDATE FOOTPRINT		
C	JB	M BOONE
5/6/2009	ECN-109863	
BOM: CHG "POLYIMIDE FILM (KAPTON)" TO "POLYIMIDE FILM"; SECTION "A": "A" CHG DIM .1280 TO .1280 + .0030/- .0010.		
D	TW	J FREEMAN
6/24/2009	ECN-112506	
TAPE & REEL VIEW MOVE SPROCKET HOLES FROM POCKET CENTER		
E	JB	J Koch
6/24/2011	ECN-157157	
NOTES: CHG NOTE 1 "50 POS NOT..." TO "50 POS, CONTACT AREA NOT..."; UPDATE TO STD, BOM CHG ITEM 2 C 126-01-L TO ASP-137228-04-P-L.		
F	VZ	B ASHLEY
4/7/2013	ECN-201427	
SECTION "A": "A" CHG C1 TO C1-B, I-DC; TOP VIEW: ADD C2-B-DC TO OAL DIM 1.2313; BOM, ITEM 3: CHG K-850-850 TO K-DOT-.325-.450-.005, CHG QTY FROM 50000 TO 1.0000.		

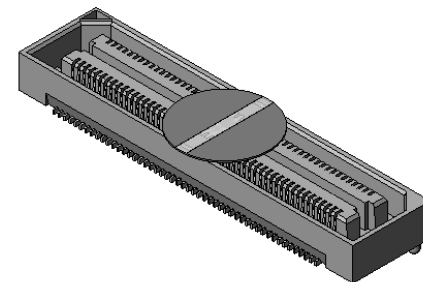
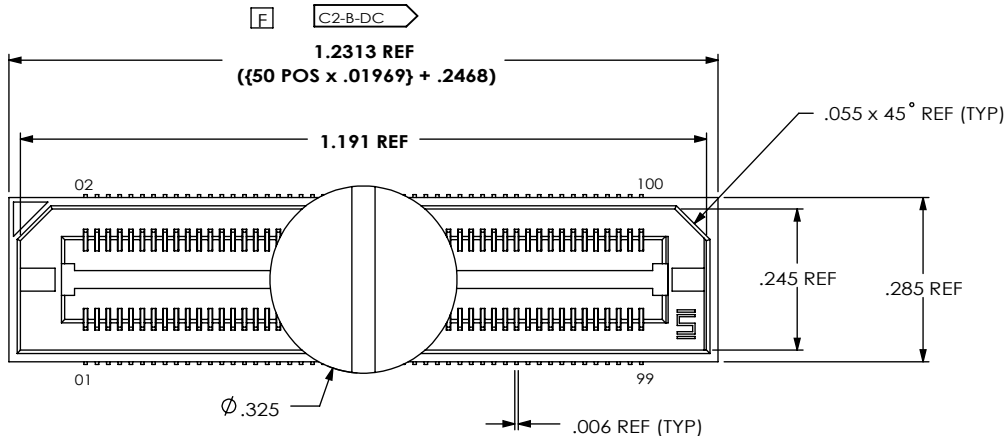

NOTES:

- 50 POS, CONTACT AREA NOT AVAILABLE AS STANDARD.
- ADD KAPTON PAD AND PACKAGE IN TAPE & REEL.
- Ⓢ REPRESENTS A CRITICAL DIMENSION.
- MAXIMUM BURR ALLOWANCE: .0015
- MINIMUM PUSHOUT FORCE: .5 OZ.
- MAXIMUM ALLOWABLE BOW: .002 INCH/INCH AFTER ASSEMBLY.
- HOLES ARE FOR OPTIONAL AGILENT SHROUD NOT SUPPLIED BY SAMTEC.
- PARTS TO BE PACKAGED IN TAPE AND REEL.

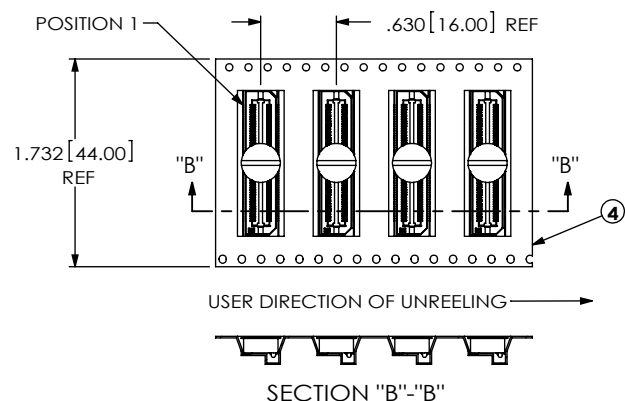
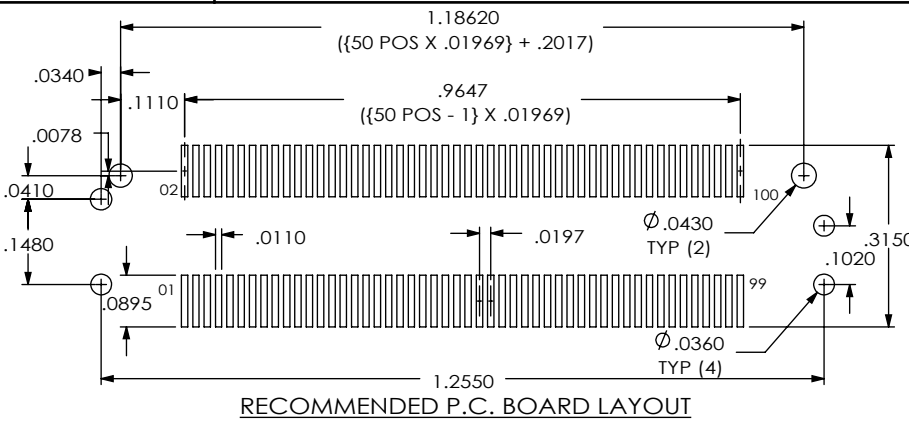
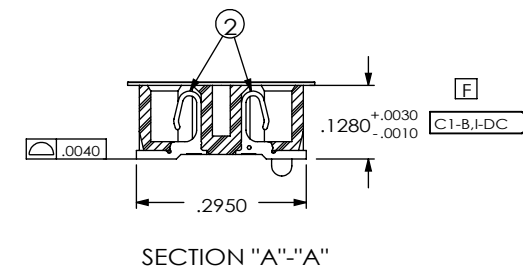
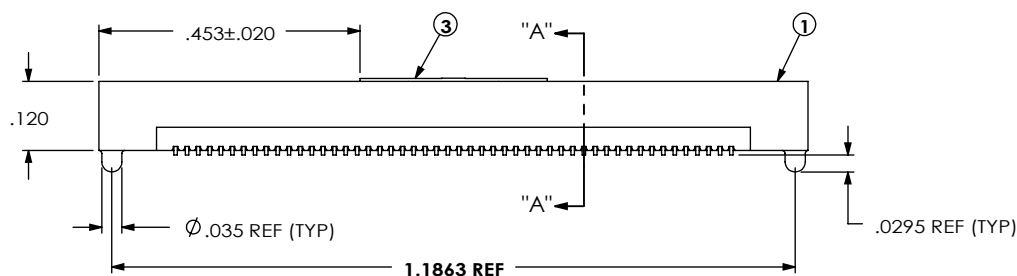

TAPE & REEL VIEW
(POCKET NOT DETAILED)

F

ITEM NO.	PART NUMBER	QUANTITY	MATERIAL
1	BSH-050-01-D-A	1.0000	VECTRA E130i, COLOR: BLACK
2	ASP-137228-04-P-L	100.00	PHOS BRONZE, 510 SPRING TEMPER
3	K-DOT-.325-.450-.005	1.0000	POLYIMIDE FILM
4	CT-ASP717MS	1.0000	CONDUCTIVE POLYMER

UNLESS OTHERWISE SPECIFIED, DIMENSIONS ARE IN INCHES. TOLERANCES ARE:
 DECIMALS ANGLES
 .XX: ±.01 2°
 .XXX: ±.005
 .XXXX: ±.0020

PROPRIETARY NOTE
 THIS DOCUMENT CONTAINS INFORMATION CONFIDENTIAL AND PROPRIETARY TO SAMTEC, INC. AND SHALL NOT BE REPRODUCED OR TRANSFERRED TO OTHER DOCUMENTS OR DISCLOSED TO OTHERS OR USED FOR ANY PURPOSE OTHER THAN THAT WHICH IT WAS OBTAINED WITHOUT THE EXPRESSED WRITTEN CONSENT OF SAMTEC, INC.



520 PARK EAST BLVD, NEW ALBANY, IN 47150
 PHONE: 812-944-6733 FAX: 812-948-5047
 e-Mail: info@SAMTEC.com code 55322

DO NOT SCALE DRAWING SHEET SCALE: 3:1
 PLATING:
 CONTACT AREA: .000010 MIN GOLD OVER .000050 NICKEL
 REMAINDER: .000003 MIN GOLD OVER .000050 NICKEL

DESCRIPTION: .5mm DOUBLE ROW SOCKET ASSEMBLY
DWG. NO. ASP-65067-01-K-TR
BY: BRYANT 06/19/03 SHEET 1 OF 1