

Specification

Date : Oct. 13, 06

TO : Beceem

Approved by

Selling agency
KYOCERA Corporation
(Electronic Components Sales Division)
〒612-8501 6 Takeda Tobadono-cho, Fushimi-ku
Kyoto 612-8501
TEL 075-604-3500, FAX 075-604-3501

Manufacturer
KYOCERA KINSEKI Corporation
〒201-8648 1-8-1 Izumi-Honcho Komae-shi,
Tokyo 201-8648
TEL 03-5497-3111, FAX 03-5497-3209

Let us Submit 1 Copy of the approved Specification on the below items.

Product	Crystal Oscillator
Model	KT3225R40000ECV28TBA (Pb-Free / RoHS Compliant)
Frequency	40.0MHz
Specification No.	_____
Customer Parts No.	_____

Engineering KYOCERA KINSEKI Yamagata Corporation Crystal Oscillator Manufacturing Department Crystal Oscillator Engineering section	Issued by N. Nakano <i>N. Nakano</i>	Approved by Y. Tachiiri <i>Y. Tachiiri</i>	Drawing No. K1101-06303-561
--	--	--	--------------------------------

※Recycled paper is being used for the conservation of nature.

KYOCERA KINSEKI Corporation

KBSK-5110C

Revision History

Revision No.	Revision Date	Customer Receipt Date	Supplier Receipt Date	Revision Content and reason	Notes	Approved by	Checked by	Prepared by
1	06/10/13			◎Document not based on Beceem Specification. ○The first edition.		<i>[Signature]</i>	<i>[Signature]</i>	<i>[Signature]</i>

1. Purpose and scope

This document contains specification related to CRYSTAL OSCILLATOR model KT3225R40000ECV28TBA for Beceem.

2. Nominal condition

	Item	Rating
1	Operating temperature range	-30°C to +80°C
2	Storage temperature range	-40°C to +85°C
3	Nominal frequency	40.0 MHz
4	Supply voltage	2.8V±5%
5	Load impedance	10kΩ//10pF±10%
6	Output signal condition	Clipped sine wave (Without DC-cut)

3. Electrical characteristics

Ta= -30°C to +80°C, Vcc=2.8V, Vc=GND, Load 10kΩ//10pF

	Item	Specification
1	Frequency stability	
	1	Temp characteristics ±2.5 × 10 ⁻⁶ max./-30°C to +80°C (On the basis of 25°C frequency)
	2	Voltage characteristics ±0.3 × 10 ⁻⁶ max./2.8V±5%
	3	Load characteristics ±0.3 × 10 ⁻⁶ max./10kΩ//10pF±10%
	4	Aging characteristics ±1.0 × 10 ⁻⁶ max./year (at 25°C±2°C)
	5	Frequency Tolerance ±1.5 × 10 ⁻⁶ max. (After reflow soldering. Ref. at nominal frequency) (at 25°C±2°C)
2	Current	2.0 mA max.
3	Output voltage	0.8 Vp-p min.
4	Harmonics	-5dBc max.

4. TYPICAL EXTERNAL COMPONENT CONNECTION

※1 Bypass Capacitor and DC-Blocking Capacitor do not build in this TCXO. So, Bypass Capacitor and DC-Blocking Capacitor are attached outside and please use it. And these Capacitor should be placed as close as possible to the pin(No.3 and No.4).
 ※2

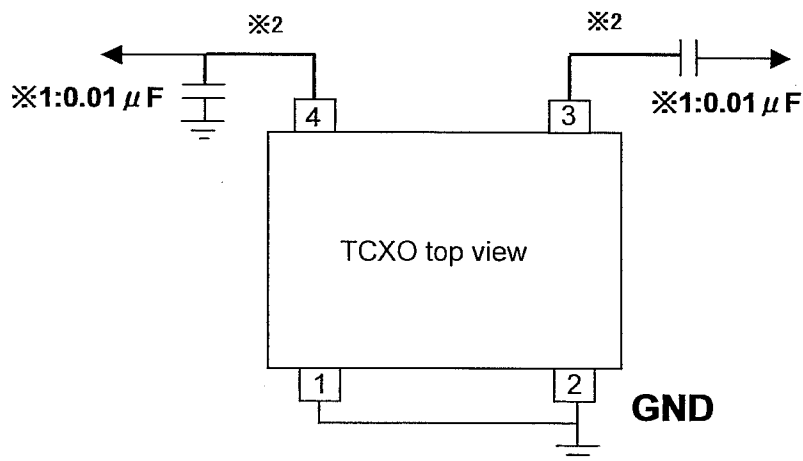

5. Environment

After the following test, shall meet electrical specification and there shall be no change of appearance.

	Item	Specification
1	Thermal shock test	Test to consist of exposing unit to -40°C for 30 minutes then to $+85^{\circ}\text{C}$ for 30 minutes hundred cycles shall complete the test. After reaching the normal condition in 24 hours.
2	Fall down test	Drop 3 times to hard wooden board Height is 75 cm.
3	Vibration	Gave 5 to 36Hz 1.5mm amplitude(5 to 500Hz)or 5G Acceleration (55 to 500Hz) every 20 minutes or sweep time. Should be applied for 2 hours for 3 cycles in each of the X,Y and Z operation.
4	Humidity storage	Stored in chamber keeping $+65^{\circ}\text{C} \pm 2^{\circ}\text{C}$ / 95% for 500 hours. After close, leaving the normal condition for 24 hours.
5	High temperature Storage	Stored in chamber keeping $+85^{\circ}\text{C}$ for 500 hours. After close, leaving the normal condition for 24 hours.

Normal Condition : Temperature $25^{\circ}\text{C} \pm 2^{\circ}\text{C}$
 Humidity 30 % ~ 70 %

6. Mountability

After the following test, shall meet electrical specification and there shall be no change of appearance.

	Item	Specification
1	Solder heat shock Stability	All leads shall be soldered at temperature of $340^{\circ}\text{C} \pm 5^{\circ}\text{C}$ for 3 sec min. using a soldering iron.
2	Lead soldering stability	Dip each of lead into $230^{\circ}\text{C} \pm 5^{\circ}\text{C}$ solder pod for 5 ± 0.5 sec. After close, the test area of loads surfaces must be covered loads three quarters by solder. Measure frequency at room temperature. (On the basis of before reflow frequency.)
	Heart stress Emission	Early reflow heart stress emission should be complete after 2 hours 25°C leaving .
3	Reflow soldering	Temperature of 260°C max for 5 second. After close leaving the normal condition for 24 hours.
4	Washing	Disapprove of washing .

Reflow profile

Surface of mother board

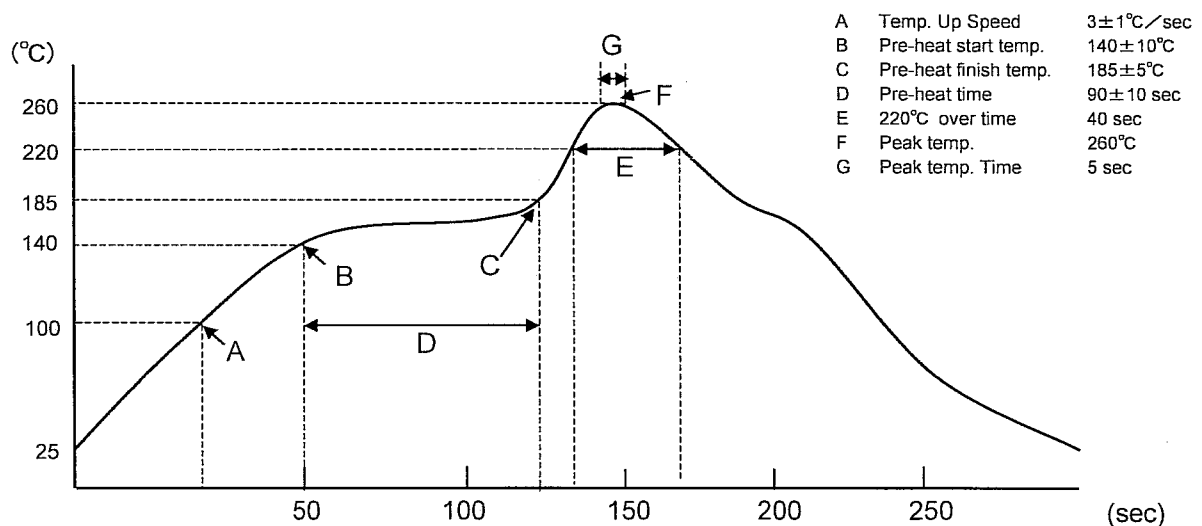

7. Marking contents

	Contents	Example
1	Control Code I	MK (KYOCERA KINSEKI Yamagata Corporation) MT (KYOCERA KINSEKI (Thailand) Co., Ltd)
2	Frequency+ Control Code II	40.0□
3	Lot No.	601
4	Pin-1 identifier	■

※ Laser Marking

8. Check item

	Item	All check	Sampling check	Guarantee of design
1	Frequency stability			
	1 Temp characteristics	◎	—	—
	2 Voltage characteristics	◎	—	—
	3 Load characteristics	—	—	◎
	4 Aging characteristics	—	—	◎
	5 Frequency tolerance	◎	—	—
2	Current	◎	—	—
3	Output voltage	◎	—	—
4	Harmonics	—	—	◎
5	Environment	—	—	◎
6	Mountability	—	—	◎
7	Final check of Frequency tolerance (QC)	—	◎	—

*Product test data is not normally attached to mass production orders. If data should be necessary, this must be separately ordered at time of order placement.

9. Dimensions

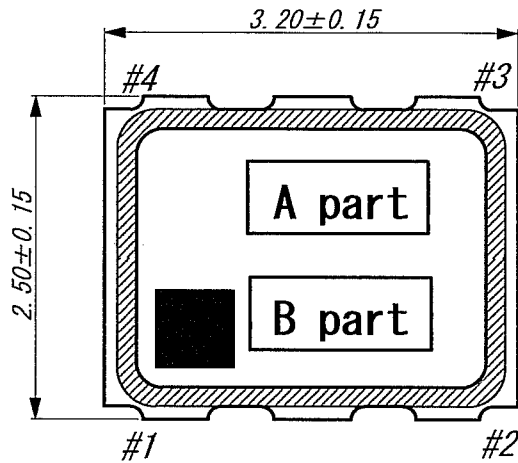

* Refer to Marking contents

A part : Frequency+ Control Code II

B part : Control Code I + Lot Number

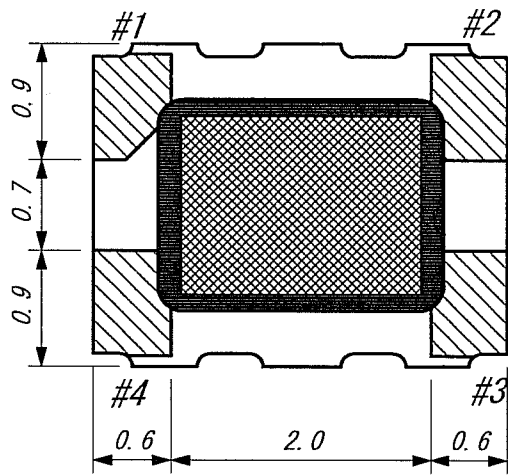
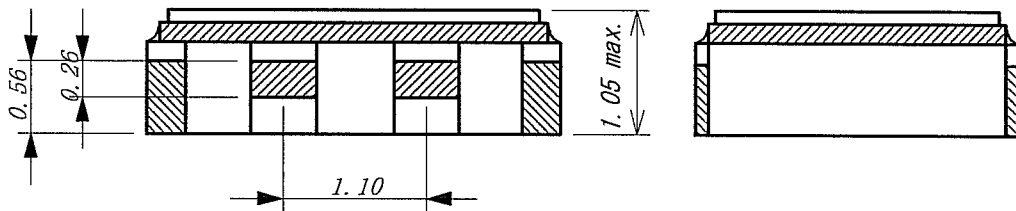

#1 GND

#2 GND

#3 OUT

#4 Vcc

Unit:mm

* Coplanarity

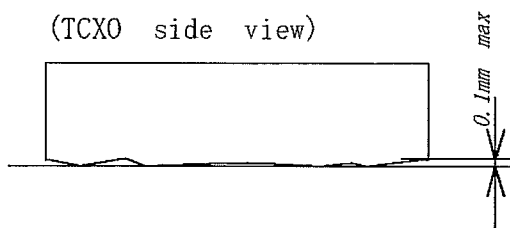

* Land pattern (Reference)

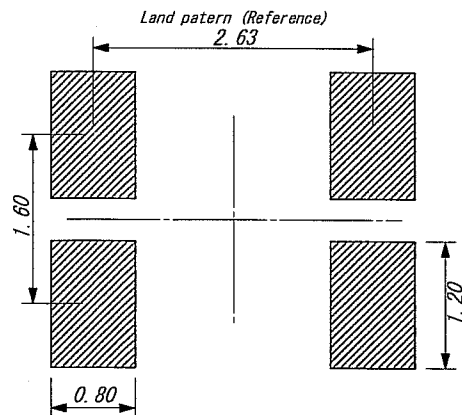

10.Packing and shipping

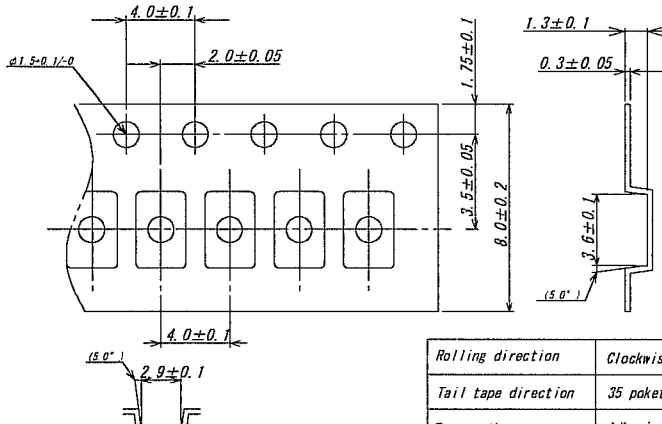
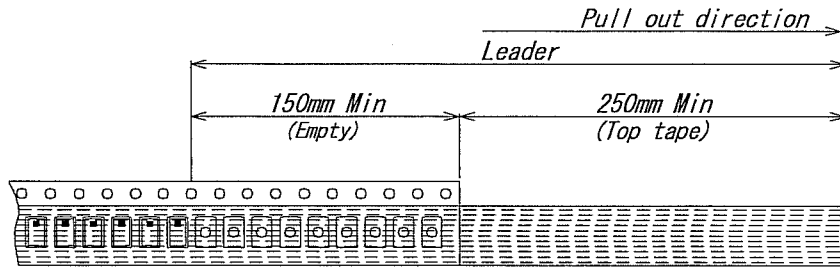

(Materials : PS or A-Pet included Carbon.)

Rolling direction	Clockwise
Tail tape direction	35 pokets Min
Tape ending management	Adhesive tape fixed on reel
Pull out strength	10N Min
Tear off strength	0.1N~0.7N (Speed 300mm/min)

Reel Dimensions

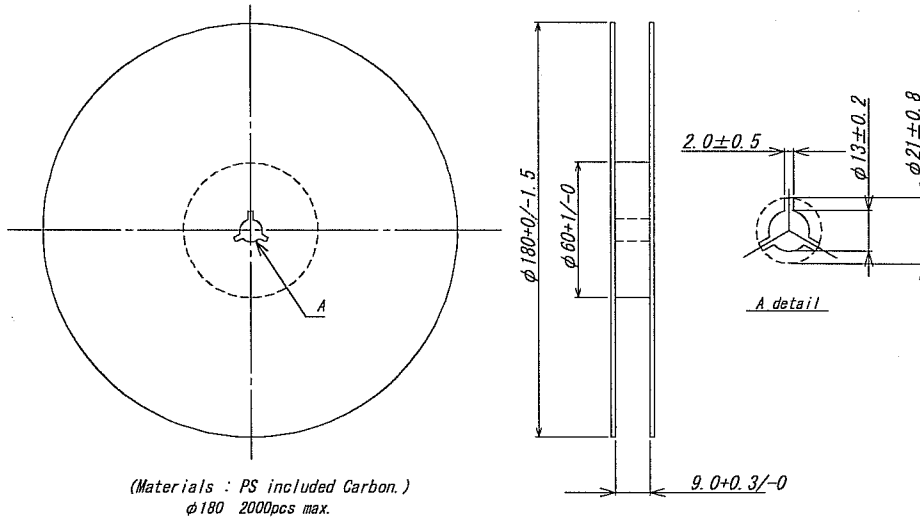

(Materials : PS included Carbon.)
 $\phi 180$ 2000pcs max.

- ① Reel diameter $\phi 180$
- ② Quantity 2000pcs
- ③ Tape width 8mm
- ④ Tape pitch 4mm
- ⑤ Set direction Guide side , Fiducail marking
- ⑥ For exclusive label No.

Packing material

Item	Item standard	Material	Antistatic
Reel	EIAJ-RRM08BC	PS Included Carbon	○
Carrier Tape	TCXO-214C-44000P	PS Included Carbon	○
Cover Film	SP-TZ (5.5×200M)	PET film	○

KYOCERA KINSEKI Corporation

Dwg No

K1101-06303-561-7/9

11. Structure of the TCXO

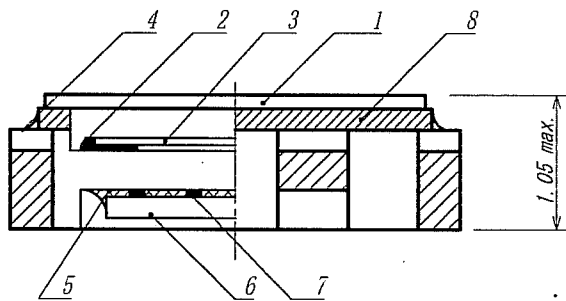
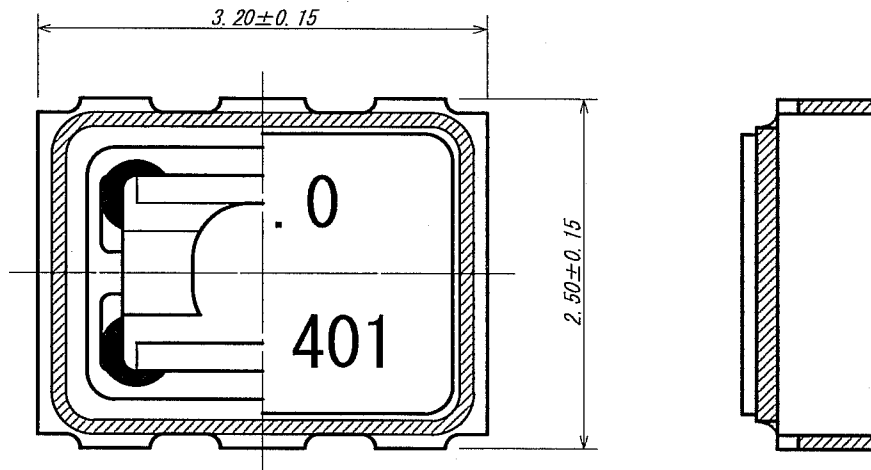

NO.	N A M E
1	Metal Lid
2	Conductive Paste
3	X'tal
4	Alumina Ceramic Package
5	Epoxy resin
6	IC Chip
7	Au Bump
8	Seal ring (KV)

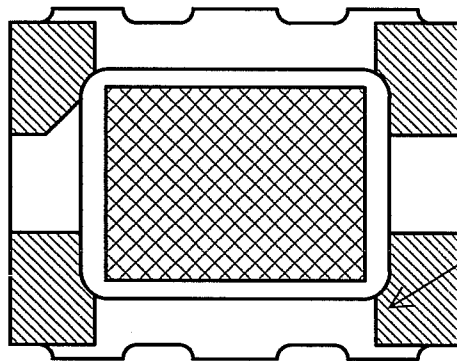

W+Ni(2~6 μm)+Au(0.5 μm)

※Flip chip bonding process is the gold gold interconnection.

12. Require careful handling

1. A thing is kept in the place which avoids direct rays and dew condensation does not produce.
2. Since there are high temperature and a possibility which comes out humidly of degrading the soldering nature of a product terminal part, about a thing if it is kept please avoid.(0~40°C, 30~70%RH)
3. Please use a thing within 168 hours after aluminum pack opening.
(A thing is kept by desiccator etc., when 168 hours after opening are exceeded. It is used after checking the product soldering nature of a thing.)

13. ESD

1. Human model 1.5KΩ 100pF: ±1000V
2. Machine model 0Ω 200pF: ±200V

14. Production place

This product is produced in KYOCERA KINSEKI Yamagata Corporation and the KYOCERA KINSEKI (Thailand) Co., Ltd.

15. Others

If you find further points in this specifications, contact us within 45 days after the date of issue.

16. Parts Numbering Guide

KT3225R 40000 E C V 28 T BA
 A B C D E F G H

- A. Series(3.2×2.5 SMD KT3225R)
- B. frequency (40.0MHz)
- C. Frequency temperature accuracy (E : +/-2.5ppm)
- D. Minimum temperature range (C:-30°C)
- E. Maximum temperature range (V :+80°C)
- F. Supply voltage(28 : 2.8V)
- G. Control voltage stability (T: TCXO)
- H. Customer special model Suffix