



+2.7 V to +5.5 V, Parallel Input, Voltage Output 8-Bit DAC

AD7801

FEATURES

- Single 8-Bit DAC
- 20-Pin SOIC/TSSOP Package
- +2.7 V to +5.5 V Operation
- Internal and External Reference Capability
- DAC Power-Down Function
- Parallel Interface
- On-Chip Output Buffer Rail-to-Rail Operation
- Low Power Operation 1.75 mA max @ 3.3 V
- Power-Down to 1 μ A max @ 25°C

APPLICATIONS

- Portable Battery Powered Instruments
- Digital Gain and Offset Adjustment
- Programmable Voltage and Current Sources
- Programmable Attenuators

FUNCTIONAL BLOCK DIAGRAM

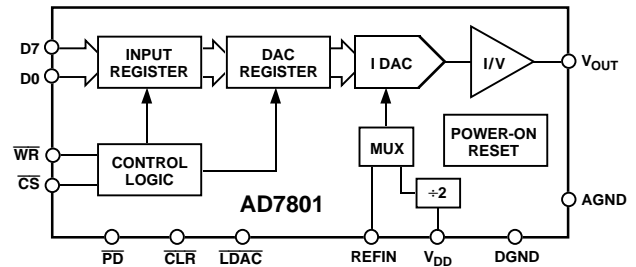

GENERAL DESCRIPTION

The AD7801 is a single, 8-bit, voltage out DAC that operates from a single +2.7 V to +5.5 V supply. Its on-chip precision output buffer allows the DAC output to swing rail to rail. The AD7801 has a parallel microprocessor and DSP compatible interface with high speed registers and double buffered interface logic. Data is loaded to the input register on the rising edge of \overline{CS} or \overline{WR} .

Reference selection for the AD7801 can be either an internal reference derived from the V_{DD} or an external reference applied at the REF pin. The output of the DAC can be cleared by using the asynchronous \overline{CLR} input.

The low power consumption of this part makes it ideally suited to portable battery operated equipment. The power consumption is less than 5 mW at 3.3 V, reducing to less than 3 μ W in power-down mode.

The AD7801 is available in a 20-lead SOIC and a 20-lead TSSOP package.

PRODUCT HIGHLIGHTS

1. Low Power, Single Supply operation. This part operates from a single +2.7 V to +5.5 V supply and consumes typically 5 mW at 3 V, making it ideal for battery powered applications.
2. The on-chip output buffer amplifier allows the output of the DAC to swing rail to rail with a settling time of typically 1.2 μ s.
3. Internal or external reference capability.
4. High speed parallel interface.
5. Power-down capability. When powered down the DAC consumes less than 1 μ A at 25°C.
6. Packaged in 20-lead SOIC and TSSOP packages.

REV. 0

Information furnished by Analog Devices is believed to be accurate and reliable. However, no responsibility is assumed by Analog Devices for its use, nor for any infringements of patents or other rights of third parties which may result from its use. No license is granted by implication or otherwise under any patent or patent rights of Analog Devices.

One Technology Way, P.O. Box 9106, Norwood, MA 02062-9106, U.S.A.
Tel: 617/329-4700 World Wide Web Site: <http://www.analog.com>
Fax: 617/326-8703 © Analog Devices, Inc., 1997

AD7801—SPECIFICATIONS

($V_{DD} = +2.7\text{ V to }+5.5\text{ V}$, Internal Reference; $C_L = 100\text{ pF}$, $R_L = 10\text{ k}\Omega$ to V_{DD} and GND. All specifications T_{MIN} to T_{MAX} unless otherwise noted.)

Parameter	B Versions ¹	Units	Conditions/Comments
STATIC PERFORMANCE			
Resolution	8	Bits	
Relative Accuracy ²	± 1	LSB max	
Differential Nonlinearity	± 1	LSB max	Guaranteed Monotonic
Zero-Code Error @ +25°C	3	LSB typ	All Zeros Loaded to DAC Register
Full-Scale Error	-0.75	LSB typ	All Ones Loaded to DAC Register
Zero-Code Error Drift	100	$\mu\text{V}/^\circ\text{C}$ typ	
Gain Error ³	± 1	% FSR typ	
DAC REFERENCE INPUT			
REFIN Input Range	1 to $V_{DD}/2$	V min/V max	
REFIN Input Impedance	10	M Ω typ	
OUTPUT CHARACTERISTICS			
Output Voltage Range	0 to V_{DD}	V min/V max	
Output Voltage Settling Time	2	μs max	Typically 1.2 μs
Slew Rate	7.5	V/ μs typ	
Digital-to-Analog Glitch Impulse	1	nV-s typ	1 LSB Change Around Major Carry
Digital Feedthrough	0.2	nV-s typ	
DC Output Impedance	40	Ω typ	
Short Circuit Current	14	mA typ	
Power Supply Rejection Ratio ⁴	0.0003	%/% max	$\Delta V_{DD} = \pm 10\%$
LOGIC INPUTS			
Input Current	± 10	μA max	
V_{INL} , Input Low Voltage	0.8	V max	$V_{DD} = +5\text{ V}$
V_{INL} , Input Low Voltage	0.6	V max	$V_{DD} = +3\text{ V}$
V_{INH} , Input High Voltage	2.4	V min	$V_{DD} = +5\text{ V}$
V_{INH} , Input High Voltage	2.1	V min	$V_{DD} = +3\text{ V}$
Pin Capacitance	7	pF max	
POWER REQUIREMENTS			
V_{DD}	2.7/5.5	V min/V max	
I_{DD} (Normal Mode)			DAC Active and Excluding Load Current
$V_{DD} = 3.3\text{ V}$			$V_{IH} = V_{DD}$ and $V_{IL} = \text{GND}$
@ 25°C	1.55	mA max	See Figure 6
T_{MIN} to T_{MAX}	1.75	mA max	
$V_{DD} = 5.5\text{ V}$			
@ 25°C	2.35	mA max	
T_{MIN} to T_{MAX}	2.5	mA max	
I_{DD} (Power-Down)			
@ 25°C	1	μA max	$V_{IH} = V_{DD}$ and $V_{IL} = \text{GND}$
T_{MIN} to T_{MAX}	2	μA max	See Figure 18

NOTES

¹Temperature ranges are as follows: B Version: -40°C to +105°C

²Relative Accuracy is calculated using a reduced code range of 15 to 245.

³Gain Error is specified between Codes 15 and 245. The actual error at Code 15 is typically 3 LSB.

⁴Guaranteed by characterization at product release, not production tested.

Specifications subject to change without notice.

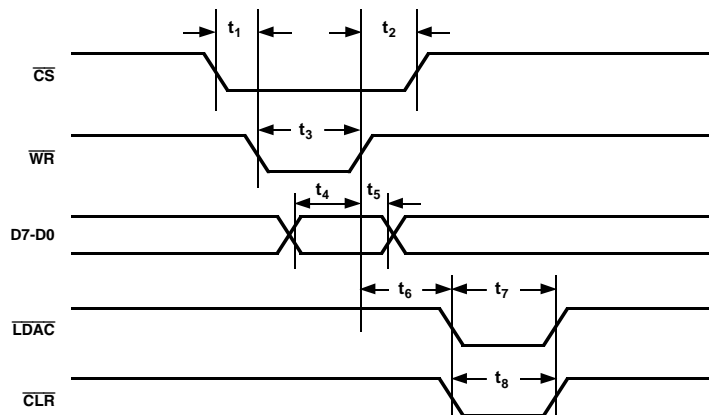

Figure 1. Timing Diagram for Parallel Data Write

TIMING CHARACTERISTICS^{1, 2} ($V_{DD} = +2.7\text{ V to }+5.5\text{ V}$; $GND = 0\text{ V}$; Internal $V_{DD}/2$ Reference. All specifications T_{MIN} to T_{MAX} unless otherwise noted.)

Parameter	Limit at T_{MIN} , T_{MAX} (B Version)	Units	Conditions/Comments
t_1	0	ns min	Chip Select to Write Setup Time
t_2	0	ns min	Chip Select to Write Hold Time
t_3	20	ns min	Write Pulse Width
t_4	15	ns min	Data Setup Time
t_5	4.5	ns min	Data Hold Time
t_6	20	ns min	Write to \overline{LDAC} Setup Time
t_7	20	ns min	\overline{LDAC} Pulse Width
t_8	20	ns min	CLR Pulse Width

NOTES

¹Sample tested at +25°C to ensure compliance. All input signals are specified with $t_r = t_f = 5\text{ ns}$ (10% to 90% of V_{DD}) and timed from a voltage level of $(V_{IL} + V_{IH})/2$. t_r and t_f should not exceed 1 μs on any digital input.

²See Figure 1.

ABSOLUTE MAXIMUM RATINGS*

($T_A = +25^\circ\text{C}$ unless otherwise noted)

V_{DD} to GND	−0.3 V to +7 V
Reference Input Voltage to AGND	−0.3 V to $V_{DD} + 0.3\text{ V}$
Digital Input Voltage to DGND	−0.3 V to $V_{DD} + 0.3\text{ V}$
AGND to DGND	−0.3 V to +0.3 V
V_{OUT} to AGND	−0.3 V to $V_{DD} + 0.3\text{ V}$
Operating Temperature Range	
Commercial (B Version)	−40°C to +105°C
Storage Temperature Range	−65°C to +150°C
Junction Temperature	+150°C
SSOP Package, Power Dissipation	700 mW
θ_{JA} Thermal Impedance	143°C/W
Lead Temperature, Soldering	
Vapor Phase (60 sec)	+215°C
Infrared (15 sec)	+220°C
SOIC Package, Power Dissipation	870 mW
θ_{JA} Thermal Impedance	74°C/W
Lead Temperature, Soldering	
Vapor Phase (60 sec)	+215°C
Infrared (15 sec)	+220°C

*Stresses above those listed under Absolute Maximum Ratings may cause permanent damage to the device. This is a stress rating only; functional operation of the device at these or any other conditions above those listed in the operational sections of this specification is not implied. Exposure to absolute maximum rating conditions for extended periods may affect device reliability.

CAUTION

ESD (electrostatic discharge) sensitive device. Electrostatic charges as high as 4000 V readily accumulate on the human body and test equipment and can discharge without detection. Although the AD7801 features proprietary ESD protection circuitry, permanent damage may occur on devices subjected to high energy electrostatic discharges. Therefore, proper ESD precautions are recommended to avoid performance degradation or loss of functionality.

ORDERING GUIDE

Model	Temperature Range	Package Option*
AD7801BR	−40°C to +105°C	R-20
AD7801BRU	−40°C to +105°C	RU-20

*R = Small Outline; RU = Thin Shrink Small Outline.



PIN CONFIGURATION

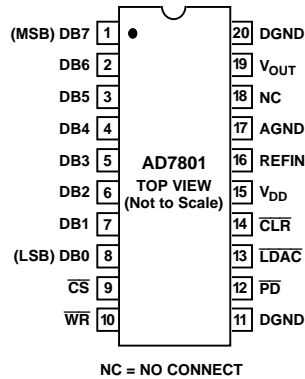

PIN FUNCTION DESCRIPTIONS

Pin No.	Mnemonic	Function
1–8	D7–D0	Parallel Data Inputs. 8-bit data is loaded to the input register of the AD7801 under the control of \overline{CS} and \overline{WR} .
9	\overline{CS}	Chip Select. Active low logic input.
10	\overline{WR}	Write Input. \overline{WR} is an active low logic input used in conjunction with \overline{CS} to write data to the input register.
11	DGND	Digital Ground
12	\overline{PD}	Active low input used to put the part into low power mode reducing current consumption to less than 1 μ A.
13	\overline{LDAC}	Load DAC Logic Input. When this logic input is taken low the DAC output is updated with the contents of its DAC register. If \overline{LDAC} is permanently tied low the DAC is updated on the rising edge of \overline{WR} .
14	\overline{CLR}	Asynchronous Clear Input (Active Low). When this input is taken low the DAC register is loaded with all zeroes and the DAC output is cleared to zero volts.
15	V_{DD}	Power Supply Input. This part can be operated from +2.7 V to +5.5 V and should be decoupled to GND.
16	REFIN	External Reference Input. This can be used as the reference for the DAC. The range on this reference input is 1 V to $V_{DD}/2$. If REFIN is tied directly to V_{DD} the internal $V_{DD}/2$ reference is selected.
17	AGND	Analog Ground reference point and return point for all analog current on the part.
18	NC	No Connect Pin.
19	V_{OUT}	Analog Output Voltage from the DAC. The output amplifier can swing rail to rail on its output.
20	DGND	Digital Ground reference point and return point for all digital current on the part.

Typical Performance Characteristics—AD7801

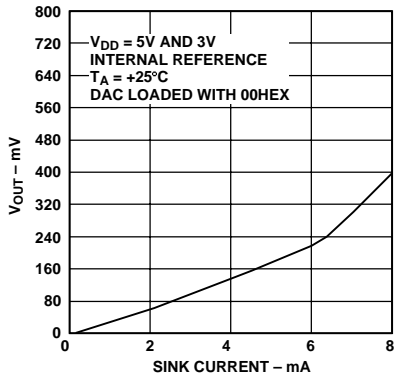

Figure 2. Output Sink Current Capability with $V_{DD} = 3\text{ V}$ and $V_{DD} = 5\text{ V}$

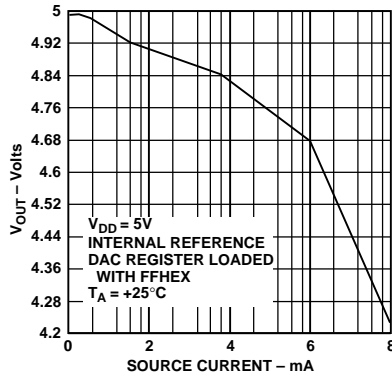

Figure 3. Output Source Current Capability with $V_{DD} = 5\text{ V}$

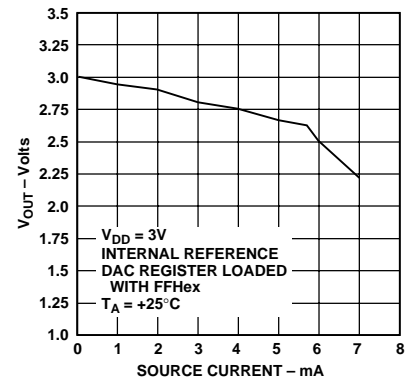

Figure 4. Output Source Current Capability with $V_{DD} = 3\text{ V}$

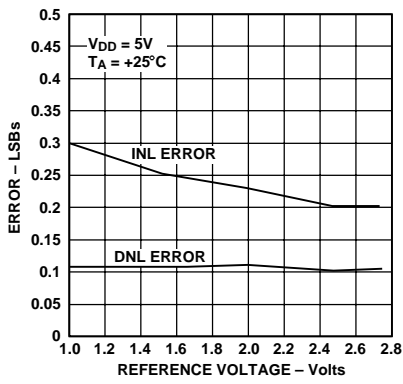

Figure 5. Relative Accuracy vs. External Reference

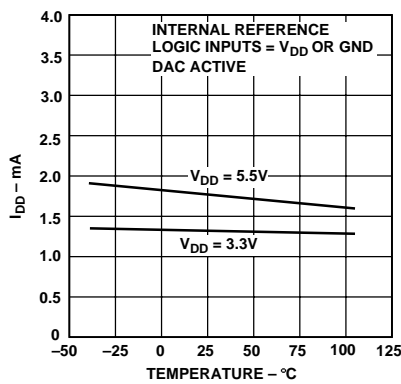

Figure 6. Typical Supply Current vs. Temperature

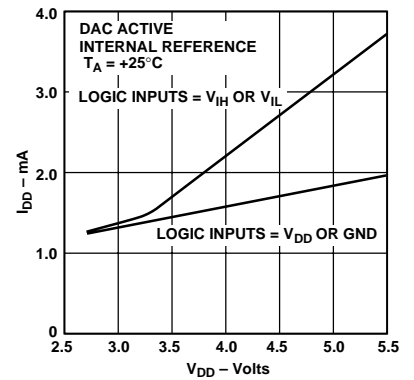

Figure 7. Typical Supply Current vs. Supply Voltage

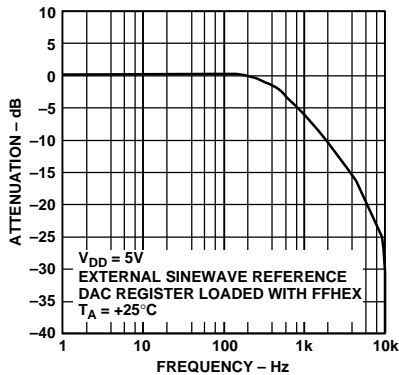

Figure 8. Large Scale Signal Frequency Response

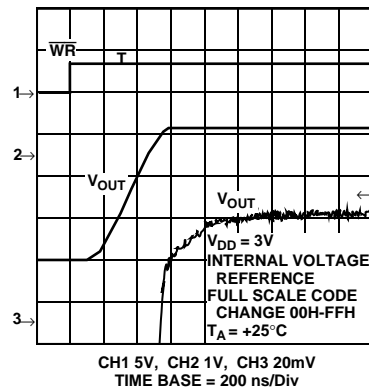

Figure 9. Full-Scale Settling Time

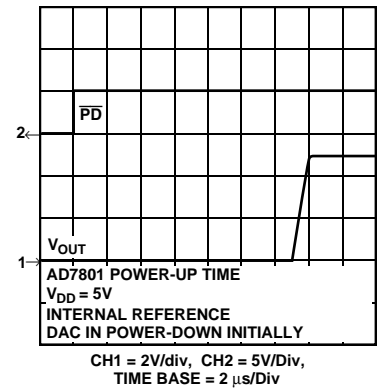

Figure 10. Exiting Power-Down (Full Power-Down)

AD7801—Typical Performance Characteristics

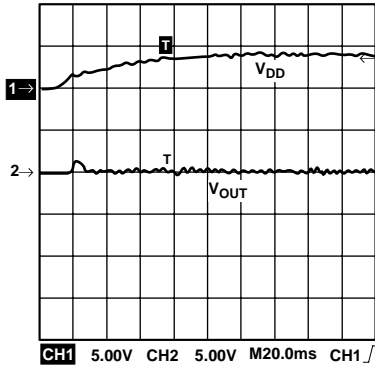

Figure 11. Power-On—Reset

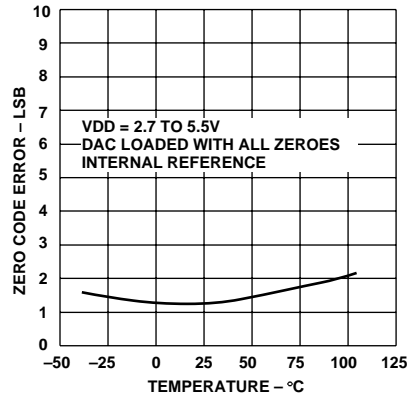

Figure 12. Zero Code Error vs. Temperature

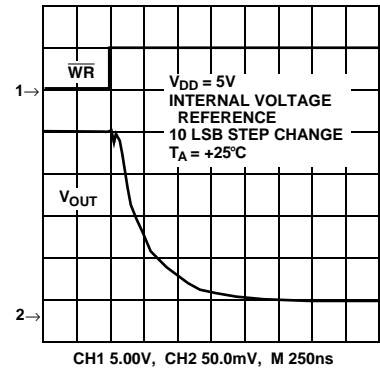

Figure 13. Small-Scale Settling Time

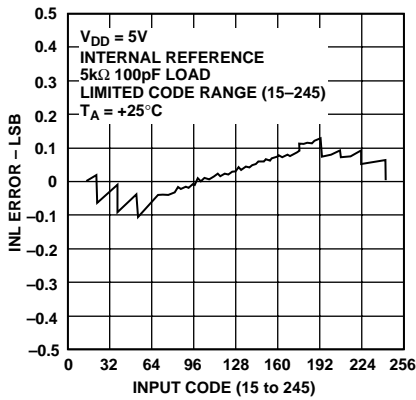

Figure 14. Integral Linearity Plot

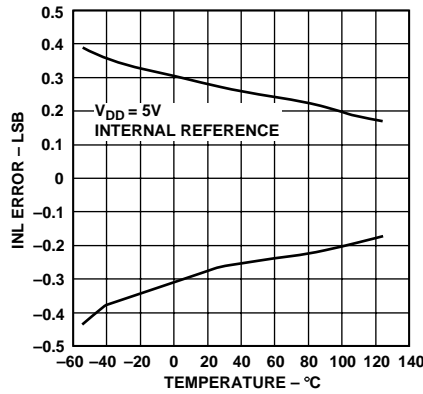

Figure 15. Typical INL vs. Temperature

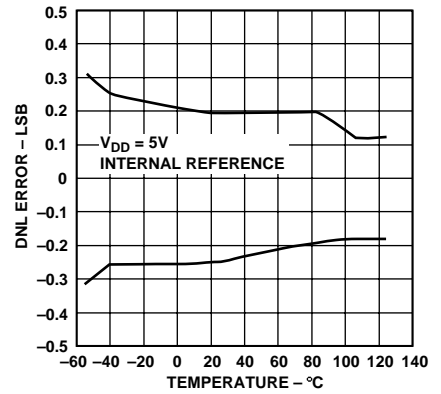

Figure 16. Typical DNL vs. Temperature

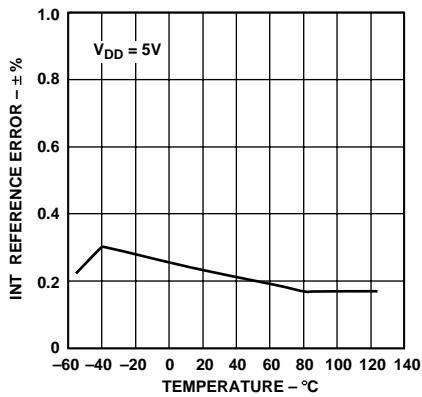

Figure 17. Typical Internal Reference Error vs. Temperature

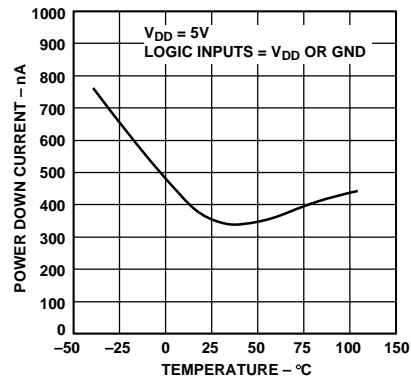

Figure 18. Power-Down Current vs. Temperature

TERMINOLOGY

Integral Nonlinearity

For the DAC, Relative Accuracy or End-Point nonlinearity is a measure of the maximum deviation, in LSBs, from a straight line passing through the endpoints of the DAC transfer function. A graphical representation of the transfer curve is shown in Figure 14.

Differential Nonlinearity

Differential Nonlinearity is the difference between the measured change and the ideal 1 LSB change between any two adjacent codes. A specified differential nonlinearity of ± 1 LSB maximum ensures monotonicity.

Zero-Code Error

Zero-Code Error is the measured output voltage from V_{OUT} of the DAC when zero code (all zeros) is loaded to the DAC latch. It is due to a combination of the offset errors in the DAC and output amplifier. Zero-code error is expressed in LSBs.

Gain Error

This is a measure of the span error of the DAC. It is the deviation in slope of the DAC transfer characteristic from ideal expressed as a percent of the full-scale value. It includes full-scale errors but not offset errors.

Digital-to-Analog Glitch Impulse

Digital-to-Analog Glitch Impulse is the impulse injected into the analog output when the digital inputs change state with the DAC selected and the \overline{LDAC} used to update the DAC. It is normally specified as the area of the glitch in nV-secs and measured when the digital input code is changed by 1 LSB at the major carry transition.

Digital Feedthrough

Digital Feedthrough is a measure of the impulse injected into the analog output of a DAC from the digital inputs of the same DAC, but is measured when the DAC is not updated. It is specified in nV-secs and measured with a full-scale code change on the data bus, i.e., from all 0s to all 1s and vice versa.

Power Supply Rejection Ratio (PSRR)

This specification indicates how the output of the DAC is affected by changes in the power supply voltage. Power supply rejection ratio is quoted in terms of % change in output per % change in V_{DD} for full-scale output of the DAC. V_{DD} is varied $\pm 10\%$.

GENERAL DESCRIPTION

D/A Section

The AD7801 is an 8-bit voltage output digital-to-analog converter. The architecture consists of a reference amplifier and a current source DAC followed by a current-to-voltage converter capable of generating rail-to-rail voltages on the output of the DAC. Figure 19 shows a block diagram of the basic DAC architecture.

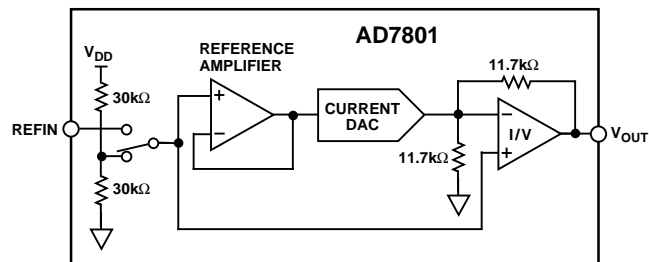

Figure 19. DAC Architecture

The DAC output is internally buffered and has rail-to-rail output characteristics. The output amplifier is capable of driving a load of 100 pF and 10 k Ω to both V_{DD} and ground. The reference selection for the DAC can be either internally generated from V_{DD} or externally applied through the REF_{IN} pin. A comparator on the REF_{IN} pin detects whether the required reference is the internally generated reference or the externally applied voltage to the REF_{IN} pin. If REF_{IN} is connected to V_{DD} , the reference selected is the internally generated $V_{DD}/2$ reference. When an externally applied voltage is more than one volt below V_{DD} , the comparator selection switches to the externally applied voltage on the REF_{IN} pin. The range on the external reference input is from 1.0 V to $V_{DD}/2$ V. The output voltage from the DAC is given by:

$$V_O = 2V_{REF} \times \left(\frac{N}{256} \right)$$

where V_{REF} is the voltage applied to the external REF_{IN} pin or $V_{DD}/2$ when the internal reference is selected. N is the decimal equivalent of the code loaded to the DAC register and ranges from 0 to 255.

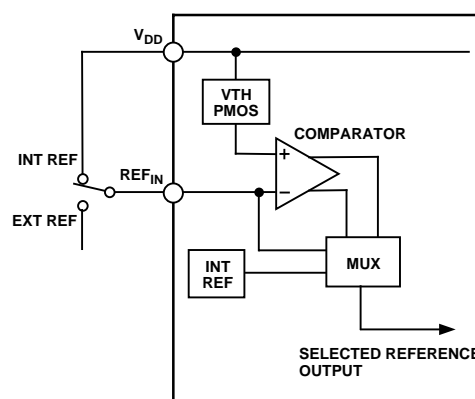

Figure 20. Reference Selection Circuitry

AD7801

Reference

The AD7801 has the ability to use either an external reference applied through the REFIN pin or an internal reference generated from V_{DD} . Figure 20 shows the reference input arrangement where either the internal $V_{DD}/2$ or the externally applied reference can be selected.

The internal reference is selected by tying the REFIN pin to V_{DD} . If an external reference is to be used, this can be directly applied to the REFIN pin and if this is 1 V below V_{DD} , the internal circuitry will select this externally applied reference as the reference source for the DAC.

Digital Interface

The AD7801 contains a fast parallel interface allowing this DAC to interface to industry standard microprocessors, microcontrollers and DSP machines. There are two modes in which this parallel interface can be configured to update the DAC output. The synchronous update mode allows synchronous updating of the DAC output; the automatic update mode allows the DAC to be updated individually following a write cycle. Figure 21 shows the internal logic associated with the digital interface. The PON STRB signal is internally generated from the power-on reset circuitry and is low during the power-on reset phase of the power up procedure.

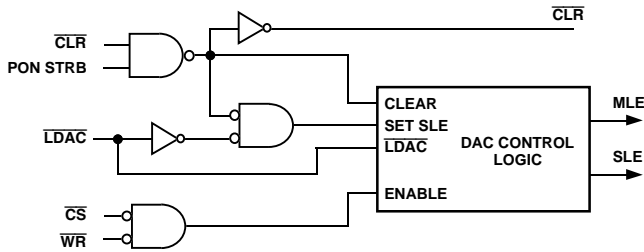

Figure 21. Logic Interface

The AD7801 has a double buffered interface, which allows for synchronous updating of the DAC output. Figure 22 shows a block diagram of the register arrangement within the AD7801.

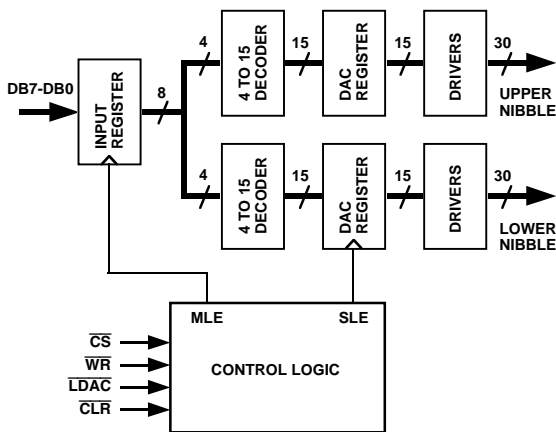

Figure 22. Register Arrangement

Automatic Update Mode

In this mode of operation the \overline{LDAC} signal is permanently tied low. The state of the \overline{LDAC} is sampled on the rising edge of \overline{WR} . \overline{LDAC} being low allows the DAC register to be automatically updated on the rising edge of \overline{WR} . The output update occurs on the rising edge of \overline{WR} . Figure 23 shows the timing associated with the automatic update mode of operation and also the status of the various registers during this frame.

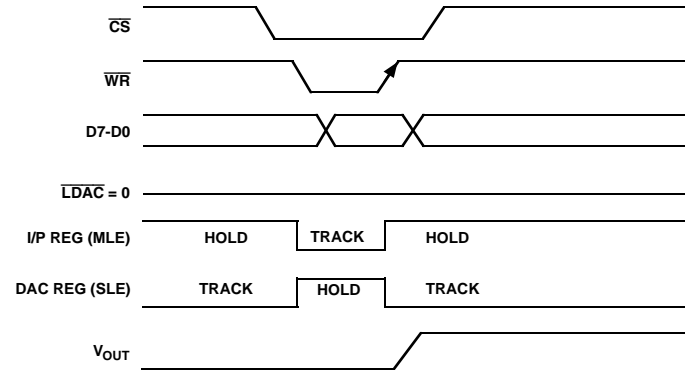

Figure 23. Timing and Register Arrangement for Automatic Update Mode

Synchronous Update Mode

In this mode of operation the \overline{LDAC} signal is used to update the DAC output to synchronize with other updates in the system. The state of the \overline{LDAC} is sampled on the rising edge of \overline{WR} . If \overline{LDAC} is high, the automatic update mode is disabled and the DAC latch is updated at any time after the write by taking \overline{LDAC} low. The output update occurs on the falling edge of \overline{LDAC} . \overline{LDAC} must be taken back high again before the next data transfer takes place. Figure 24 shows the timing associated with the synchronous update mode of operation and also the status of the various registers during this frame.

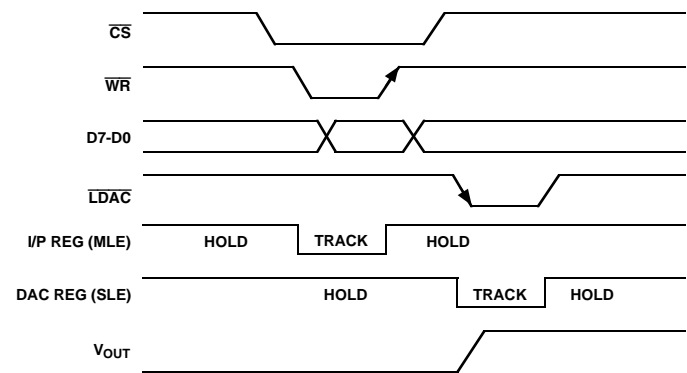

Figure 24. Timing and Register Arrangement for Synchronous Update Mode

POWER-ON RESET

The AD7801 has a power-on reset circuit designed to allow output stability during power up. This circuit holds the DAC in a reset state until a write takes place to the DAC. In the reset state all zeros are latched into the input register of the DAC and the DAC register is in transparent mode thus the output of the DAC is held at ground potential until a write takes place to the DAC. The power-on reset circuitry generates a PON STRB signal which is a gating signal used within the logic to identify a power-on condition.

POWER-DOWN FEATURES

The AD7801 has a power-down feature implemented by exercising the external PD pin. An active low signal puts the complete DAC into power-down mode. When in power-down, the current consumption of the device is reduced to less than 1 μA max at +25°C or 2 μA max over temperature, making the device suitable for use in portable battery powered equipment. The internal reference resistors, the reference bias servo loop, the output amplifier and associated linear circuitry are all shut down when the power-down is activated. The output terminal sees a load of $\approx 23 \text{ k}\Omega$ to GND when in power-down mode as shown in Figure 25. The contents of the data register are unaffected when in power-down mode. The device typically comes out of power-down in 13 μs (see Figure 10).

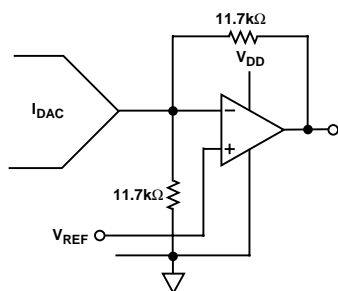

Figure 25. Output Stage During Power-Down

Analog Outputs

The AD7801 contains a voltage output DAC with 8-bit resolution and rail-to-rail operation. The output buffer provides a gain of two at the output. Figures 2, 3 and 4 show the source and sink capabilities of the output amplifier. The slew rate of the output amplifier is typically 7.5 V/ μs and has a full-scale settling to eight bits with a 100 pF capacitive load in typically 1.2 μs .

The input coding to the DAC is straight binary. Table I shows the binary transfer function for the AD7801. Figure 26 shows the DAC transfer function for binary coding. Any DAC output voltage can be expressed as:

$$V_{OUT} = 2 \times V_{REF} \left(\frac{N}{256} \right)$$

where:

N is the decimal equivalent of the binary input code. N ranges from 0 to 255.

V_{REF} is the voltage applied to the external REFIN pin when the external reference is selected and is $V_{DD}/2$ if the internal reference is used.

Table I. Output Voltage for Selected Input Codes

Digital MSB . . . LSB	Analog Output
1111 1111	$2 \times \frac{255}{256} \times V_{REF} V$
1111 1110	$2 \times \frac{254}{256} \times V_{REF} V$
1000 0001	$2 \times \frac{129}{256} \times V_{REF} V$
1000 0000	$V_{REF} V$
0111 1111	$2 \times \frac{127}{256} \times V_{REF} V$
0000 0001	$2 \times \frac{V_{REF}}{256} V$
0000 0000	0 V

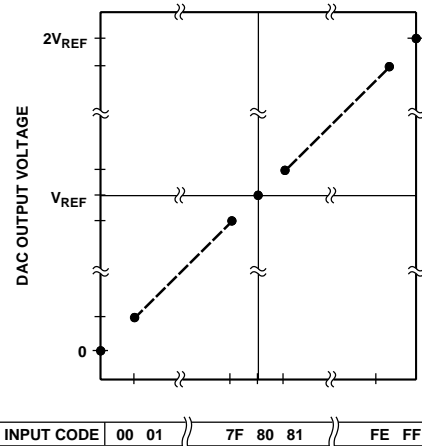

Figure 26. DAC Transfer Function

AD7801

Figure 27 shows a typical setup for the AD7801 when using its internal reference. The internal reference is selected by tying the REF IN pin to V_{DD} . Internally in the reference section there is a reference detect circuit that will select the internal $V_{DD}/2$ based on the voltage connected to the REF IN pin. If REF IN is within a threshold voltage of a PMOS device (approximately 1 V) of V_{DD} the internal reference is selected. When the REF IN voltage is more than 1 V below V_{DD} , the externally applied voltage at this pin is used as the reference for the DAC. The internal reference on the AD7801 is $V_{DD}/2$, the output current to voltage converter within the AD7801 provides a gain of two. Thus the output range of the DAC is from 0 V to V_{DD} , based on Table I.

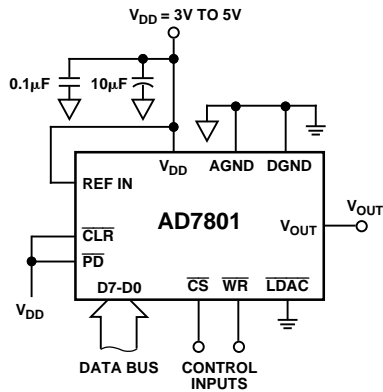

Figure 27. Typical Configuration Selecting the Internal Reference

Figure 28 shows a typical setup for the AD7801 when using an external reference. The reference range for the AD7801 is from 1 V to $V_{DD}/2$ V. Higher values of reference can be incorporated but will saturate the output at both the top and bottom end of the transfer function. There is a gain of two from input to output on the AD7801. Suitable references for 5 V operation are the AD780 and REF192. For 3 V operation a suitable external reference would be the AD589 a 1.23 V bandgap reference.

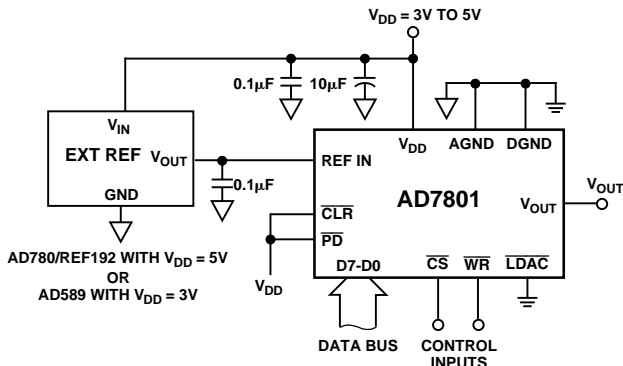

Figure 28. Typical Configuration Using An External Reference

MICROPROCESSOR INTERFACING AD7801-ADSP-2101/ADSP-2103 Interface

Figure 29 shows an interface between the AD7801 and the ADSP-2101/ADSP-2103. The fast interface timing associated with the AD7801 allows easy interface to the ADSP-2101/ADSP-2103.

\overline{LDAC} is permanently tied low in this circuit so the DAC output is updated on the rising edge of the \overline{WR} signal.

Data is loaded to the AD7801 input register using the following ADSP-21xx instruction.

$$DM(DAC) = MR0$$

MR0 = ADSP-21xx MR0 Register.

DAC = Decoded DAC Address.

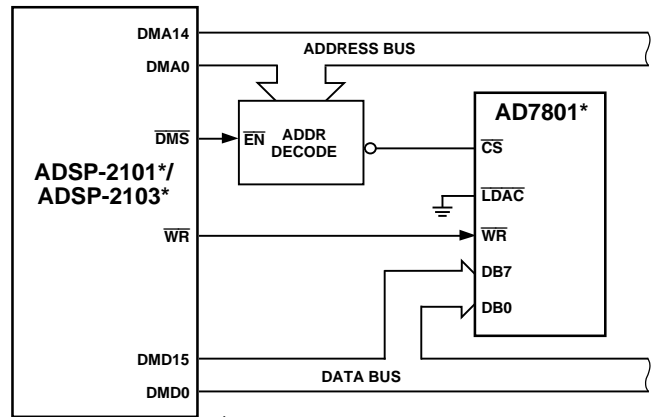

*ADDITIONAL CIRCUITRY OMITTED FOR CLARITY.

Figure 29. AD7801-ADSP-2101/ADSP-2103 Interface

AD7801-TMS320C20 Interface

Figure 30 shows an interface between the AD7801 and the TMS320C20. Data is loaded to the AD7801 using the following instruction:

$$OUT\ DAC, D$$

DAC = Decoded DAC Address.

D = Data Memory Address.

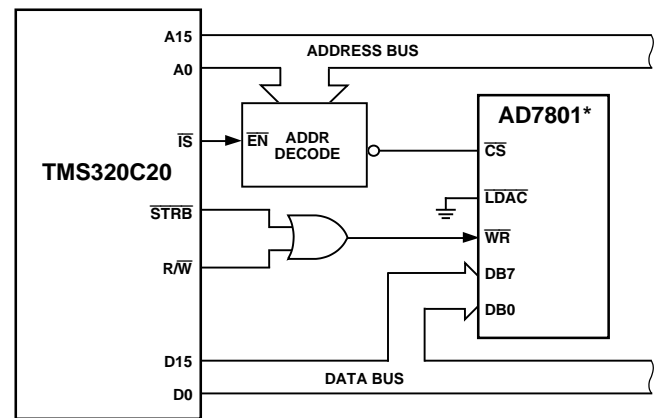

*ADDITIONAL CIRCUITRY OMITTED FOR CLARITY.

Figure 30. AD7801-TMS320C20 Interface

In the circuit shown the $\overline{\text{LDAC}}$ is hardwired low thus the DAC output is updated on the rising edge of $\overline{\text{WR}}$. Some applications may require synchronous updating of the DAC in the AD7801. In this case the $\overline{\text{LDAC}}$ signal can be driven from an external timer or can be controlled by the microprocessor. One option for synchronous updating is to decode the $\overline{\text{LDAC}}$ from the address bus so a write operation at this address will synchronously update the DAC output. A simple OR gate with one input driven from the decoded address and the second input from the $\overline{\text{WR}}$ signal will implement this function.

AD7801–8051/8088 Interface

Figure 31 shows a serial interface between the AD7801 and the 8051/8088 processors.

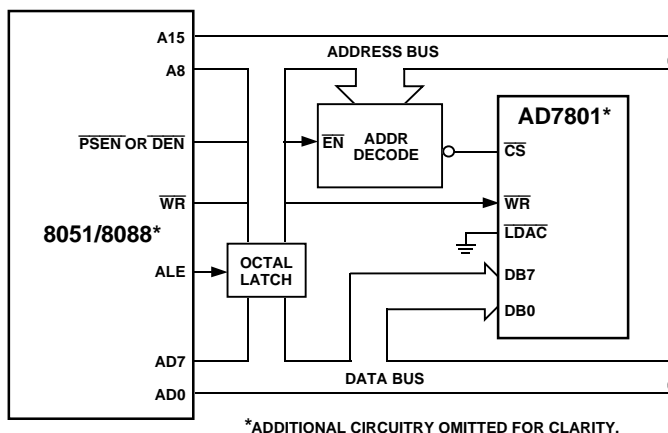

Figure 31. AD7801–8051/8088 Interface

APPLICATIONS

Bipolar Operation Using the AD7801

The AD7801 has been designed for unipolar operation but bipolar operation is possible using the circuit in Figure 32. The circuit shown is configured for an output voltage range of –5 V to +5 V. Rail-to-rail operation at the amplifier output is achievable by using an AD820 or OP295 as the output amplifier.

The output voltage for any input code can be calculated as follows:

$$V_O = \left[R_2 \left(1 + \frac{R_4}{R_3} \right) / (R_1 + R_2) \times \left(\frac{2V_{REF}D}{256} \right) - V_{REF} \left(\frac{R_4}{R_3} \right) \right]$$

Where D is the decimal equivalent of the code loaded to the DAC and V_{REF} is the reference voltage input.

With $V_{REF} = 2.5$ V, $R_1 = R_3 = 10$ k Ω and $R_2 = R_4 = 20$ k Ω and $V_{DD} = 5$ V.

$$V_O = \left(\frac{10D}{256} \right) - 5$$

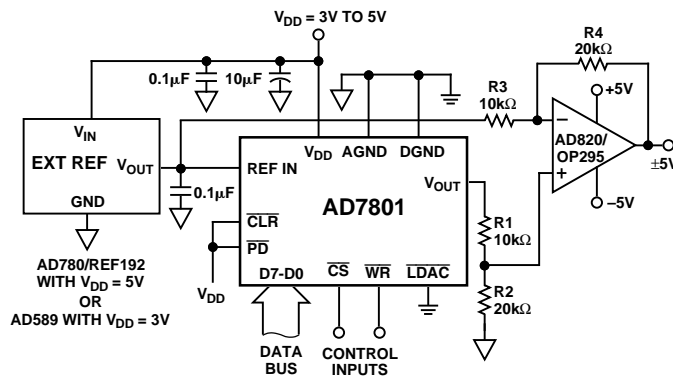

Figure 32. Bipolar Operation Using the AD7801

Decoding Multiple AD7801s in a System

The $\overline{\text{CS}}$ pin on the AD7801 can be used in applications to decode a number of DACs. In this application, all DACs in the system receive the same input data, but only the $\overline{\text{CS}}$ to one of the DACs will be active at any one time allowing access to one channel in the system. The 74HC139 is used as a two-to-four line decoder to address any of the DACs in the system. To prevent timing errors from occurring, the Enable input on the 74HC139 should be brought to its inactive state while the Coded Address inputs are changing state. Figure 33 shows a diagram of a typical setup for decoding multiple AD7801 devices in a system. The built-in power-on reset circuit on the AD7801 ensures that the outputs of all DACs in the system power up with zero volts on their outputs.

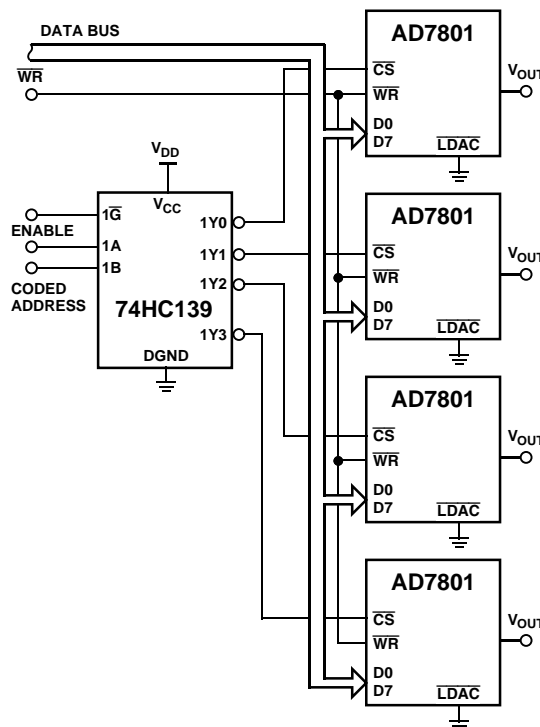

Figure 33. Decoding Multiple AD7801s

AD7801

AD7801 as a Digitally Programmable Indicator

A digitally programmable upper limit detector using the DAC is shown in Figure 34. The upper limit for the test is loaded to the DAC, which in turn sets the limit for the CMP04. If a signal at the V_{IN} input is not below the programmed value, an LED will indicate the Fail condition.

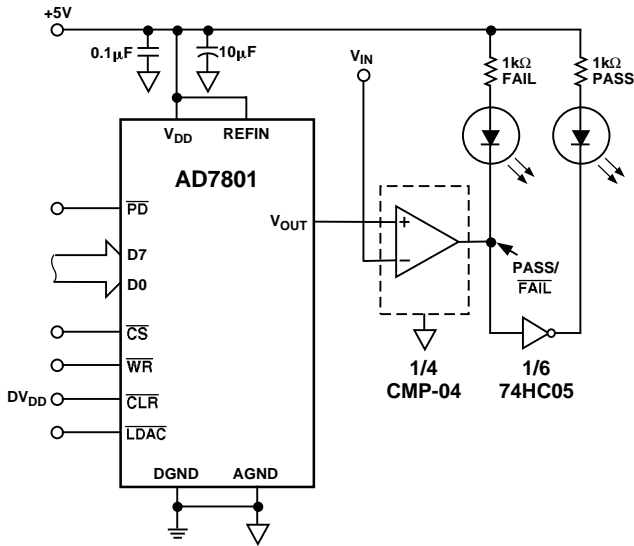

Figure 34. Digitally Programmable Indicator

Programmable Current Source

Figure 35 shows the AD7801 used as the control element of a programmable current source. In this circuit the full-scale current is set to 1 mA. The output voltage from the DAC is applied across the current setting resistor of 4.7 kΩ in series with the full-scale setting resistor of 470 Ω. Suitable transistors to place in the feedback loop of the amplifier include the BC107 and the 2N3904, which enable the current source to operate from a minimum V_{SOURCE} of 6 V. The operating range is determined by the operating characteristics of the transistor. Suitable amplifiers include the AD820 and the OP295, both of which have rail-to-rail operation on their outputs. The current for any digital input code can be calculated as follows:

$$I = \frac{(2 V_{REF D})}{(256 (5 k\Omega))}$$

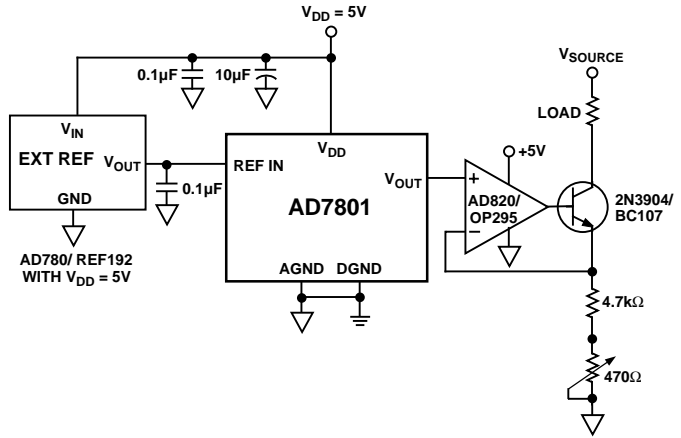

Figure 35. Programmable Current Source

Coarse and Fine Adjustment using two AD7801s

The two DACs can be paired together to form a coarse and fine adjustment function for a setpoint as shown in Figure 36. In this circuit, the first DAC is used to provide the coarse adjustment and the second DAC is used to provide the fine adjustment. Varying the ratio of R1 and R2 will vary the relative effect of the coarse and fine tune elements in the circuit. For the resistor values shown, the second DAC has a resolution of 148 µV giving a fine tune range of 38 mV (approximately 2 LSB) for operation with a V_{DD} of 5 V and a reference of 2.5 V. The amplifier shown allows a rail-to-rail output voltage to be achieved on the output. A typical application for the circuit would be in a setpoint controller.

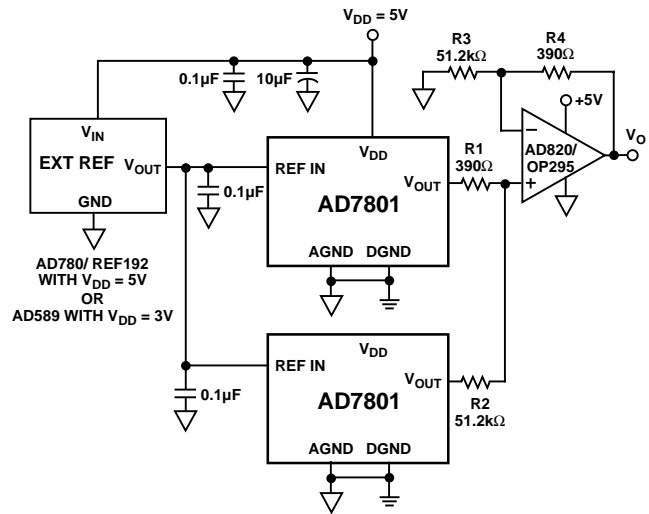

Figure 36. Coarse and Fine Adjustment

Power Supply Bypassing and Grounding

In any circuit where accuracy is important, careful consideration of the power supply and ground return layout helps to ensure the rated performance. The printed circuit board on which the AD7801 is mounted should be designed so that the analog and digital sections are separated and confined to certain areas of the board. If the AD7801 is in a system where multiple devices require an AGND to DGND connection, the connection should be made at one point only, a star ground point which should be established as closely as possible to the AD7801. The AD7801 should have ample supply bypassing of 10 μF in parallel with 0.1 μF located as close to the package as possible, ideally right up against the device. The 10 μF capacitors are the tantalum bead type. The 0.1 μF capacitors should have low Effective Series Resistance (ESR) and Effective Series Inductance (ESI), such as the common ceramic types, which provide a low impedance path to ground at high frequencies to handle transient currents due to internal logic switching.

The power supply lines of the AD7801 should use as large a trace as possible to provide low impedance paths and reduce the effects of glitches on the supply line. Fast switching signals like clocks should be shielded with digital ground to avoid radiating noise to other parts of the board and should never be run near reference inputs. Avoid crossover of digital and analog signals. Traces on opposite sides of the board should run at right angles to each other. This reduces the effect of feedthrough through the board. A microstrip technique is by far the best, but not always possible with a double-sided board. In this technique, the component side of the board is dedicated to the ground plane while signal traces are placed on the solder side.

OUTLINE DIMENSIONS

Dimensions shown in inches and (mm).

**20-Lead Wide Body SOIC
(R-20)**

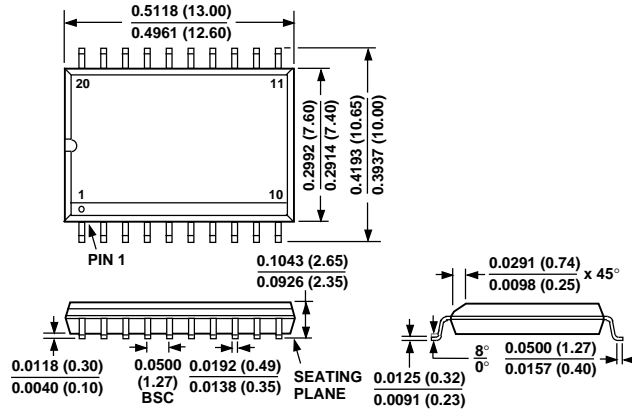

**20-Lead TSSOP
(RU-20)**

