

CONTACT SIZE	MIN. INSUL O.D	MAX. INSUL O.D	TYPICAL WIRE RANGE	CURRENT RATING
12	3.40mm (.134 in)	4.32mm (.170 in)	12-14AWG	25 AMPS

REVISIONS					
REV	ECO	DESCRIPTION	DATE	BY	APPR
A1	-	RELEASE	11APR2019	JAH	-

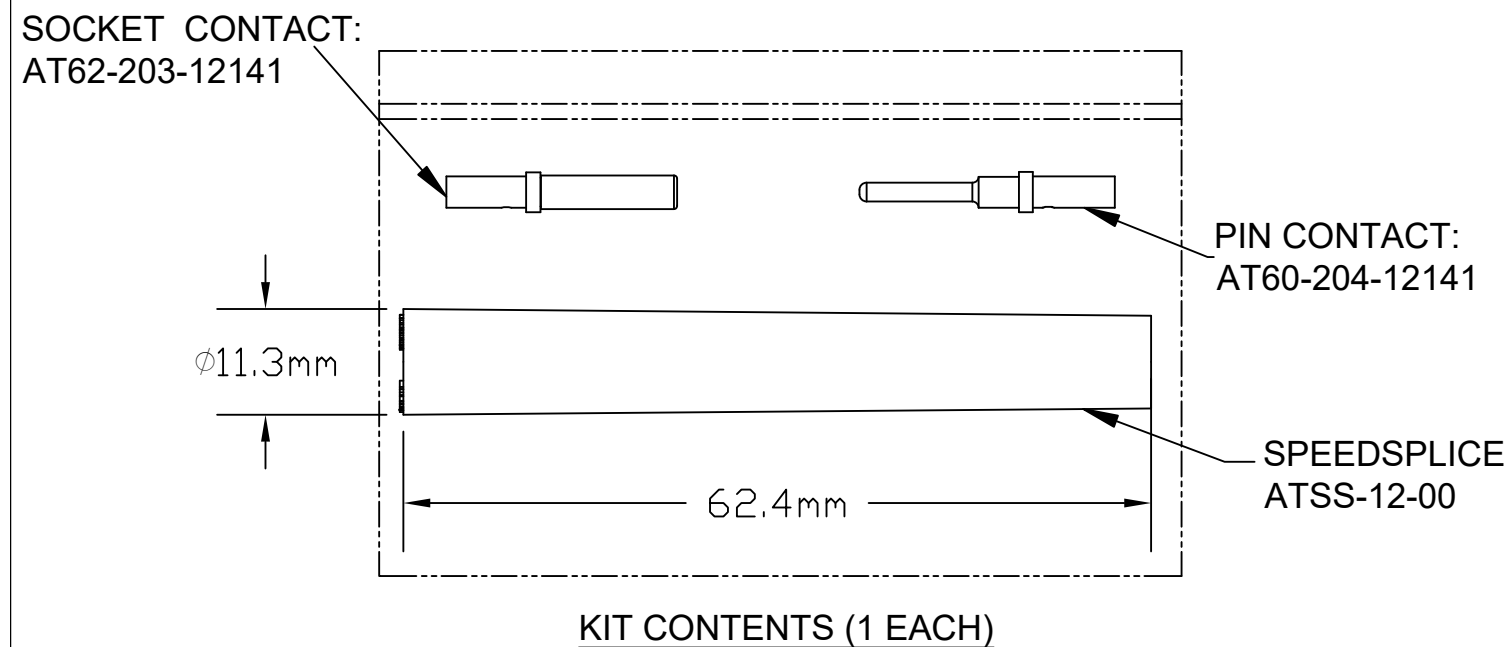

P/N	DEUTSCH CROSS
ATSS-12-00	JS-12-00
AT60-204-12141	0460-204-12141
AT62-203-12141	0462-203-12141

1. MATERIAL:  
CONTACTS: COPPER ALLOY; NICKEL PLATED  
INTEGRATED CONTACT RETENTION SYSTEM  
SPEEDSPlice SEAL: SILICONE RUBBER

2. CONTACT SIZE: 12

3. SPECIFICATIONS:  
3.1 CURRENT RATING: 25AMPS  
3.2 CONTACT MILLIVOLT DROP: 60MILLIVOLT  
DROP @ 125AMP TEST CURRENT.  
3.3 RoHS COMPLIANT

4. RECOMMENDED WIRE RANGE: 12-14AWG

5. AVAILABLE HAND CRIMPER: CA-5D12

6. ALL DIMENSIONS ARE FOR REFERENCE USE ONLY

ASSY P/N	RECOMMENDED WIRE RANGE	PIN CONTACT P/N	SOCKET CONTACT P/N
ATSS-12-KIT01	12-14AWG	AT60-204-12141	AT62-203-12141

QUANTITY	PART NUMBER	DESCRIPTION	ITEM
MATERIALS LIST			
UNLESS OTHERWISE SPECIFIED 1) All dimensions are in metric (mm). 2) Tolerances are as follows: 1 PL DEC ±0.30 2 PL DEC ±0.15 Fractions ±1/64 3 PL DEC ±0.08 Angles ±1° 3) Note reference =		SIGNATURES DATE DRAWN: J.HEAD 11APR2019 CHECKED: ENGINEER: APPROVAL: CUSTOMER:	
MATERIAL SPECIFICATIONS:		<h1 style="text-align: center;">Amphenol</h1> <p style="text-align: center;">Sine Systems - www.amphenol-sine.com 44724 Morley Drive Clinton Township, MI 48036</p> <p style="text-align: center;"><b>KIT, SPEEDSPlice &amp; SIZE 12 SOLID CONTACTS. 12-14 AWG</b></p>	
PROCESS SPECIFICATIONS:			
NEXT ASS'Y:		SIZE: A TYPE: C DWG NO: ATSS-12-KIT01 REVISION: A1 SCALE: NONE SHEET 1 OF 1	