

Turbo 2 ultrafast high voltage rectifier

Datasheet - production data

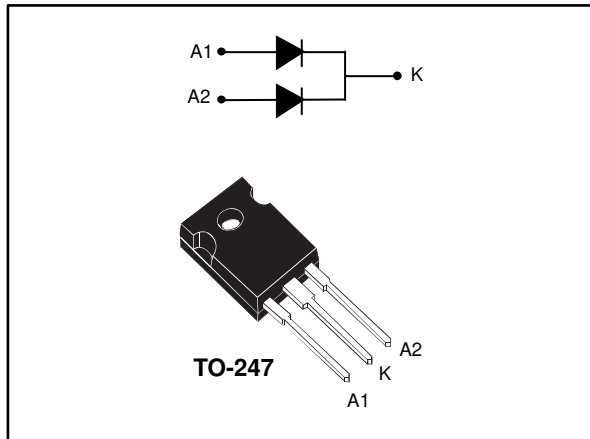

Description

This device using ST Turbo 2 600 V technology, is specially suited as boost diode in continuous mode power factor corrections and hard switching conditions.

The device is also intended for use as a free wheeling diode in power supplies and other power switching applications.

Table 1: Device summary

Symbol	Value
$I_{F(AV)}$	2 x 15 A
V_{RRM}	600 V
I_{RM} (typ.)	8 A
T_j (max.)	175 °C
V_F (typ.)	1.8 V
t_{rr} (max.)	50 ns

Features

- Ultrafast switching
- Low reverse current
- Low thermal resistance
- Reduced switching and conduction losses

1 Characteristics

Table 2: Absolute ratings (limiting values, per diode)

Symbol	Parameter	Value	Unit	
V _{RRM}	Repetitive peak reverse voltage	600	V	
I _{F(RMS)}	Forward rms current	30	A	
I _{F(AV)}	Average forward current	T _c = 115 °C, δ = 0.5, per diode	15	A
		T _c = 100 °C, δ = 0.5, per device	30	
I _{FSM}	Surge non repetitive forward current	t _p = 10 ms sinusoidal	120	A
T _{stg}	Storage temperature range	-65 to +175	°C	
T _j	Maximum operating junction temperature	175	°C	

Table 3: Thermal parameters

Symbol	Parameter	Max. value	Unit	
R _{th(j-c)}	Junction to case	Per diode	1.5	°C/W
		Total	1.0	
R _{th(c)}	Coupling	0.5		

Table 4: Static electrical characteristics (per diode)

Symbol	Parameter	Test conditions		Min.	Typ.	Max.	Unit
I _R ⁽¹⁾	Reverse leakage current	T _j = 25 °C	V _R = V _{RRM}	-		60	µA
		T _j = 125 °C		-	70	800	
V _F ⁽²⁾	Forward voltage drop	T _j = 25 °C	I _F = 15 A	-		2.9	V
		T _j = 125 °C		-	1.4	1.8	

Notes:

⁽¹⁾Pulse test: t_p = 5 ms, δ < 2%

⁽²⁾Pulse test: t_p = 380 µs, δ < 2 %

To evaluate the conduction losses, use the following equation:

$$P = 1.16 \times I_{F(AV)} + 0.043 \times I_{F(RMS)}^2$$

Table 5: Dynamic electrical characteristics

Symbol	Parameters	Test conditions		Min.	Typ.	Max.	Unit
t_{rr}	Reverse recovery time	$T_j = 25\text{ °C}$	$I_F = 0.5\text{ A}$, $I_{rr} = 0.25\text{ A}$, $I_R = 1\text{ A}$	-		30	ns
			$I_F = 1\text{ A}$, $dI_F/dt = -50\text{ A}/\mu\text{s}$, $V_R = 30\text{ V}$	-		50	
I_{RM}	Reverse recovery current	$T_j = 125\text{ °C}$	$I_F = 15\text{ A}$, $dI_F/dt = -200\text{ A}/\mu\text{s}$, $V_R = 400\text{ V}$	-	7.5	9.0	A
S factor	Softness factor			-	0.15		
Q_{rr}	Reverse recovery charges			-	220		nC
t_{fr}	Forward recovery time	$T_j = 25\text{ °C}$	$I_F = 15\text{ A}$, $dI_F/dt = 120\text{ A}/\mu\text{s}$, $V_{FR} = 1.1 \times V_{Fmax}$	-		200	ns
V_{FP}	Forward recovery voltage			-		6	V

1.1 Characteristics (curves)

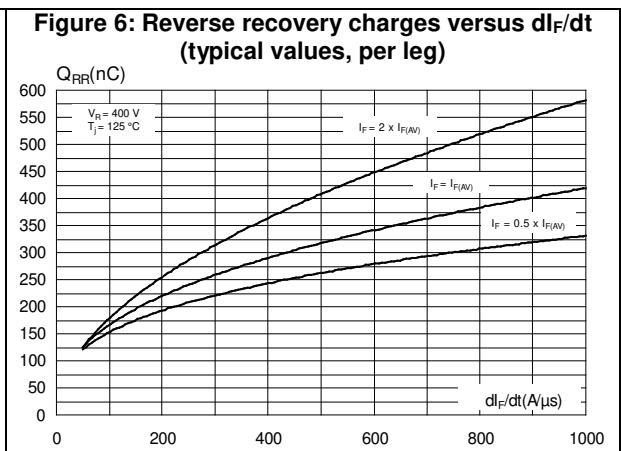
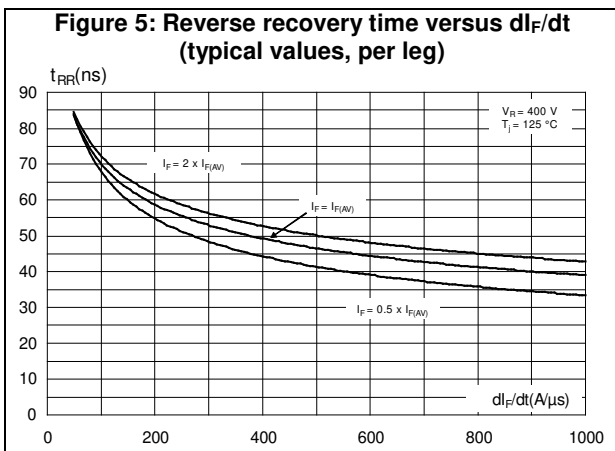
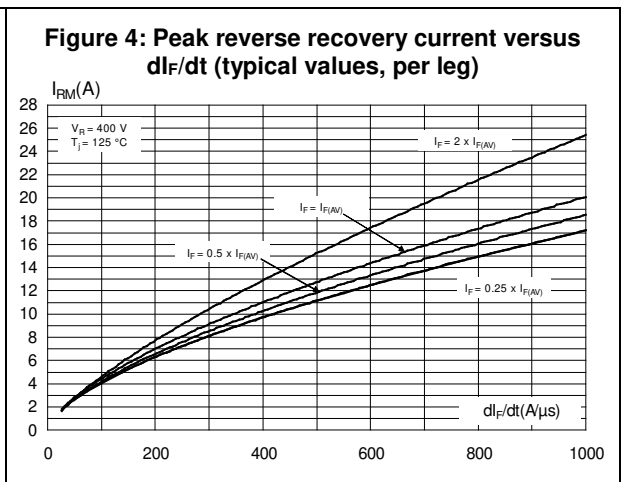
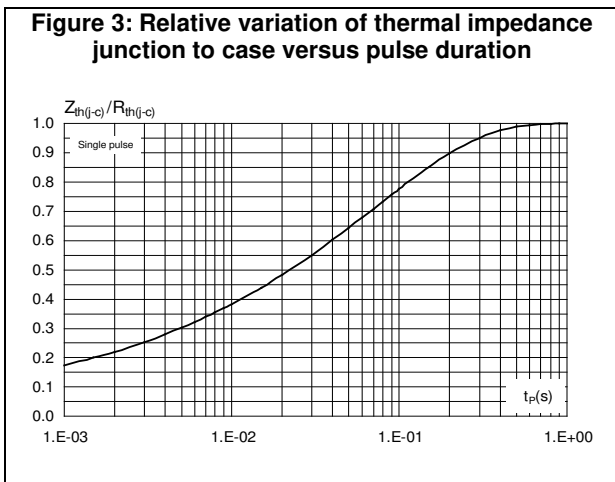
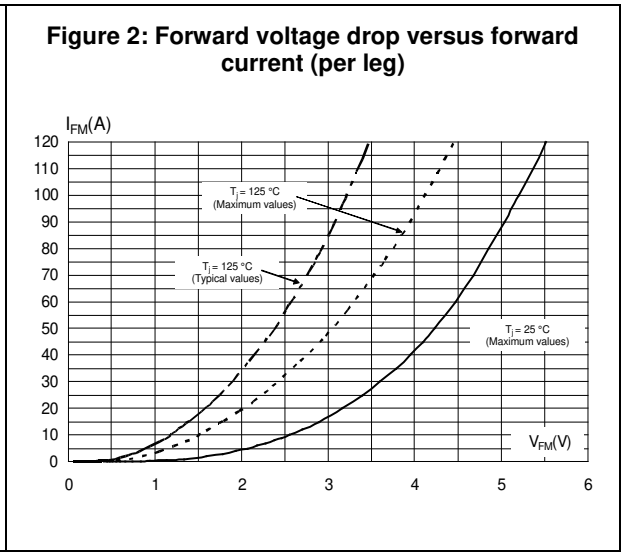
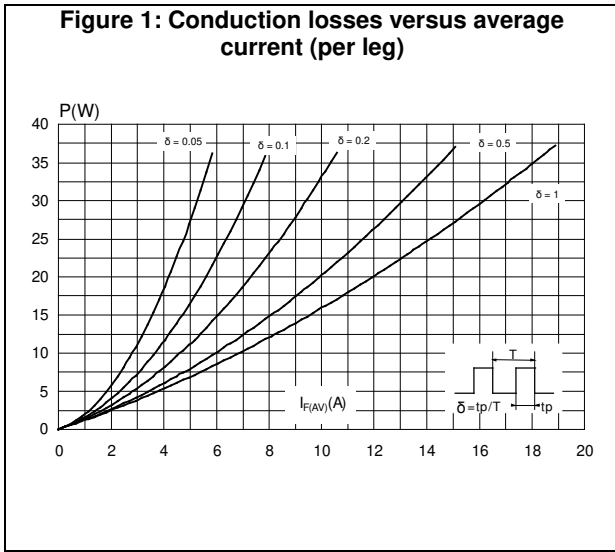

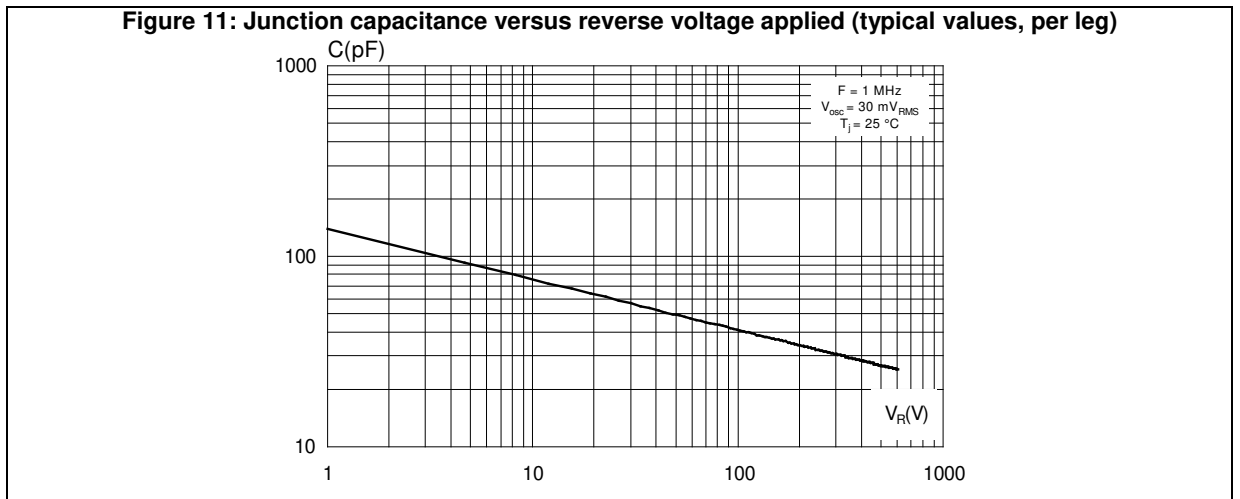
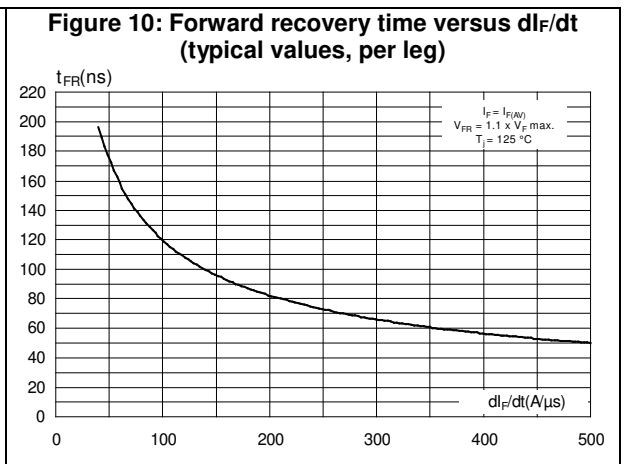
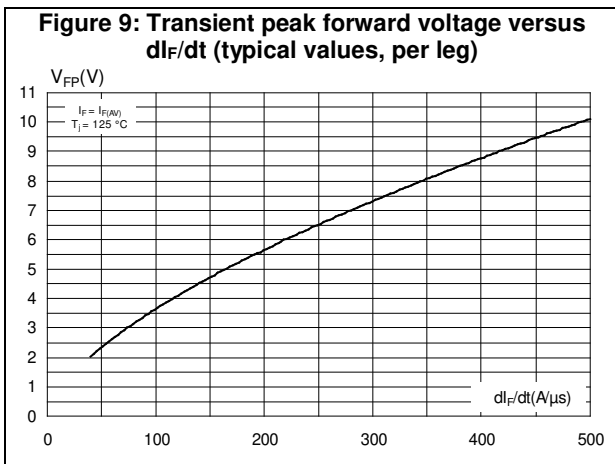
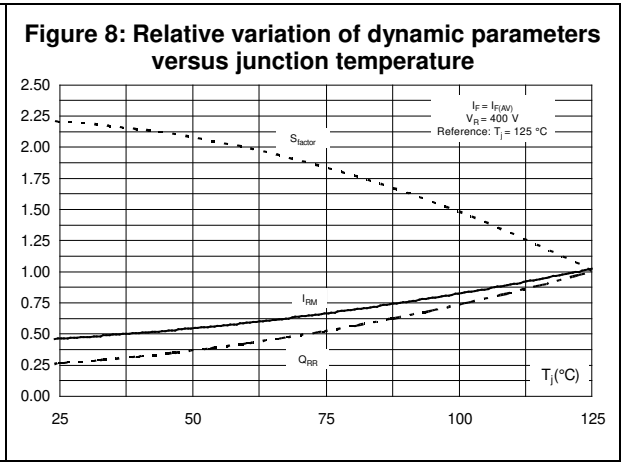
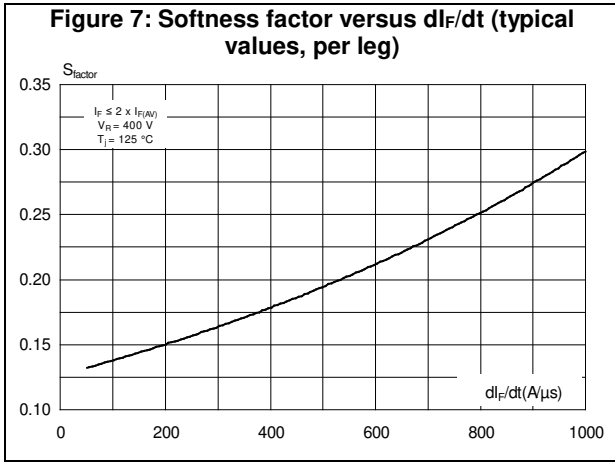

2 Package information

In order to meet environmental requirements, ST offers these devices in different grades of ECOPACK® packages, depending on their level of environmental compliance. ECOPACK® specifications, grade definitions and product status are available at: www.st.com. ECOPACK® is an ST trademark.

- Epoxy meets UL94, V0
- Cooling method: by conduction (C)
- Recommended torque values: 0.8 N·m
- Maximum torque value: 1.0 N·m

2.1 TO-247 package information

Figure 12: TO-247 package outline

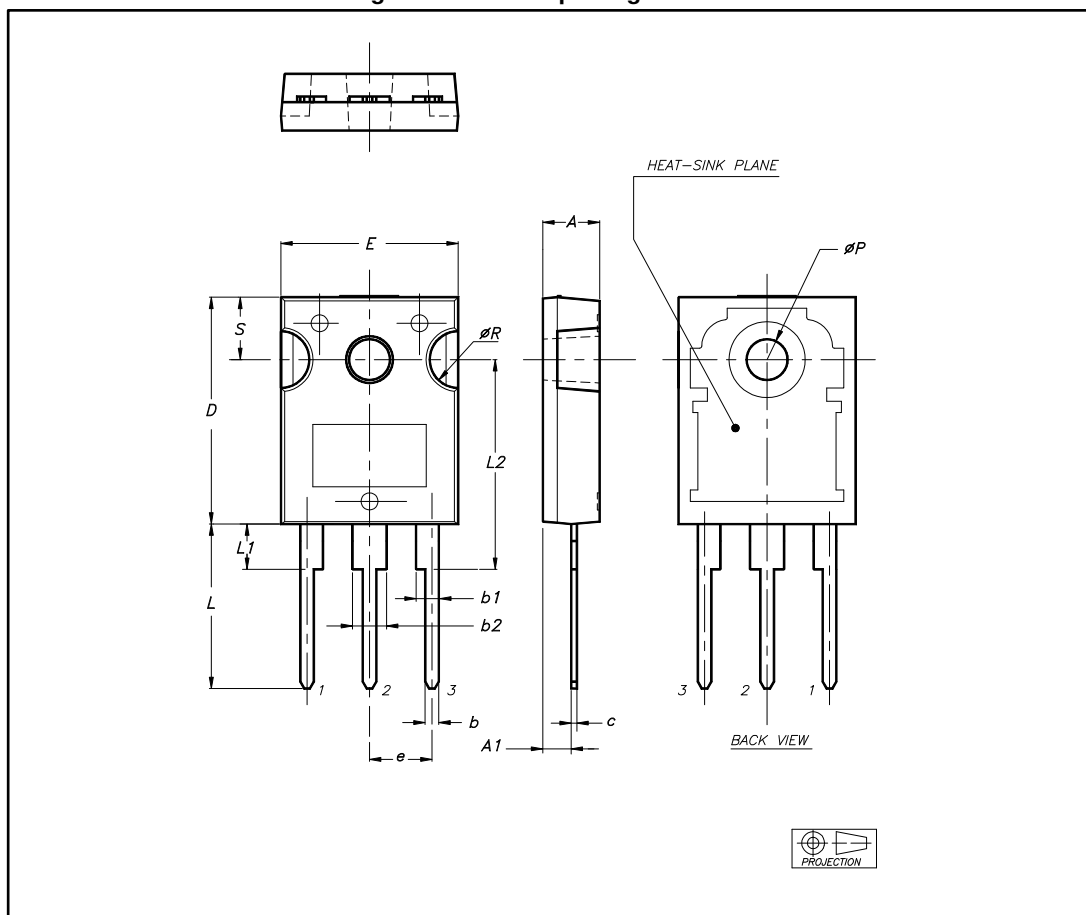

Table 6: TO-247 package mechanical data

Ref.	Dimensions					
	Millimeters			Inches		
	Min.	Typ.	Max.	Min.	Typ.	Max.
A	4.85		5.15	0.191		0.203
A1	2.20		2.60	0.086		0.102
b	1.00		1.40	0.039		0.055
b1	2.00		2.40	0.078		0.094
b2	3.00		3.40	0.118		0.133
c	0.40		0.80	0.015		0.031
D ⁽¹⁾	19.85		20.15	0.781		0.793
E	15.45		15.75	0.608		0.620
e	5.30	5.45	5.60	0.209	0.215	0.220
L	14.20		14.80	0.559		0.582
L1	3.70		4.30	0.145		0.169
L2		18.50			0.728	
ØP ⁽²⁾	3.55		3.65	0.139		0.143
ØR	4.50		5.50	0.177		0.217
S	5.30	5.50	5.70	0.209	0.216	0.224

Notes:

⁽¹⁾Dimension D plus gate protusion does not exceed 20.5 mm

⁽²⁾Resin thickness around the mounting hole is not less than 0.9 mm.

3 Ordering information

Table 7: Ordering information

Order code	Marking	Package	Weight	Base qty.	Delivery mode
STTH30R06CW	STTH30R06CW	TO-247	4.36 g	30	Tube

4 Revision history

Table 8: Document revision history

Date	Revision	Changes
July-2001	1	Last issue.
18-Jun-2014	2	Updated title. ECOPACK statement updated.
16-Feb-18	3	Updated Section 1.1: "Characteristics (curves)" .

IMPORTANT NOTICE – PLEASE READ CAREFULLY

STMicroelectronics NV and its subsidiaries ("ST") reserve the right to make changes, corrections, enhancements, modifications, and improvements to ST products and/or to this document at any time without notice. Purchasers should obtain the latest relevant information on ST products before placing orders. ST products are sold pursuant to ST's terms and conditions of sale in place at the time of order acknowledgement.

Purchasers are solely responsible for the choice, selection, and use of ST products and ST assumes no liability for application assistance or the design of Purchasers' products.

No license, express or implied, to any intellectual property right is granted by ST herein.

Resale of ST products with provisions different from the information set forth herein shall void any warranty granted by ST for such product.

ST and the ST logo are trademarks of ST. All other product or service names are the property of their respective owners.

Information in this document supersedes and replaces information previously supplied in any prior versions of this document.

© 2018 STMicroelectronics – All rights reserved