

10 9 8 7 6 5 4 3 2 1

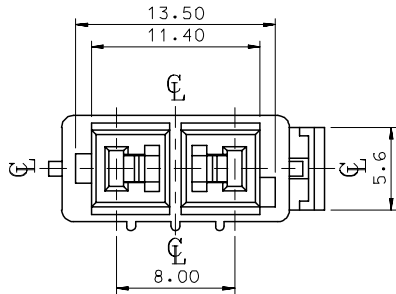

VIEW "A"

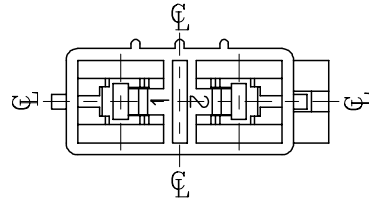

↑ "A"

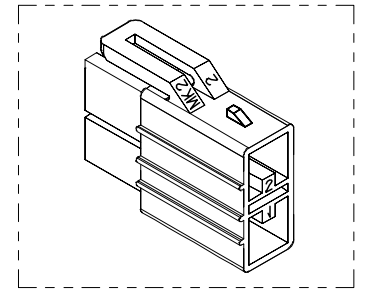

NOTES

1. MATERIAL & COLOR : SEE TABLE
2. MATCHED HOUSING : 35180-060*
3. APPLICABLE TERMINAL : 35748-0*10
4. APPLICABLE T.P.A : 35182-019*

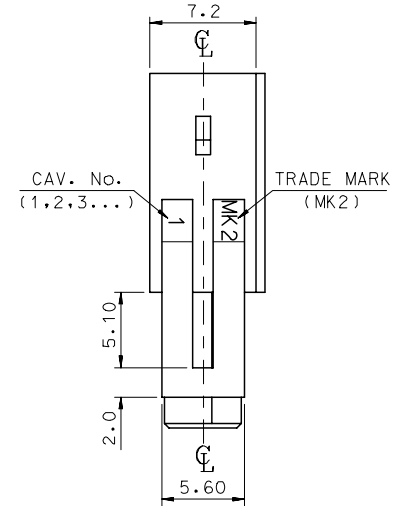
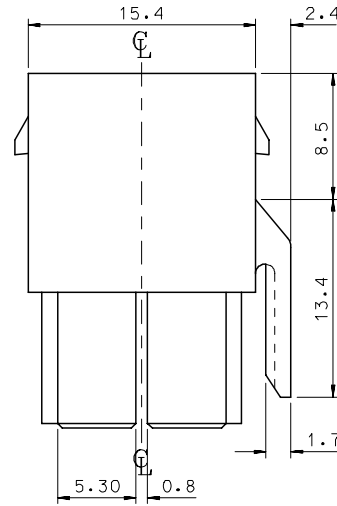
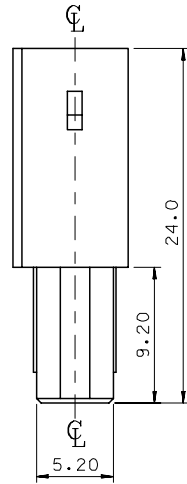

NO	PRODUCT		MATERIAL	
	PART NO	MATERIAL NO	COLOR	DESCRIPTION
1	35181-0220	351810220	NATURAL	PBT (UL94V-0)
2	35181-0229	351810229	NATURAL	PBT/PC(UL94V-0)

REVISED
 EC NO: KOR2008-0078
 DRWN: JHPARK01 2007/09/10
 CHKD: WY. YANG 2007/09/10
 APPR: YUNSIKKIM 2007/09/10

QUALITY SYMBOLS
 ▽=0
 ▽=0

GENERAL TOLERANCES (UNLESS SPECIFIED)	
mm	INCH
4 PLACES ± ---	± ---
3 PLACES ± ---	± ---
2 PLACES ± ---	± ---
1 PLACE ± 0.3	± ---
ANGULAR ± 1 °	

DRAFT WHERE APPLICABLE MUST REMAIN WITHIN DIMENSIONS

DIMENSION STYLE
 MM ONLY

DRAWN BY
 JS. KANG

CHECKED BY

APPROVED BY

MATERIAL NO.

SIZE
 A3

SCALE
 3:1

DESIGN UNITS
 METRIC

THIRD ANGLE PROJECTION

TITLE
 .070 MULTI W/W CONN
 FEMALE HSG-2P(C)

MOLEX INCORPORATED

DOCUMENT NO.
 SD-35181-022*

SHEET NO.
 1 OF 01

THIS DRAWING CONTAINS INFORMATION THAT IS PROPRIETARY TO MOLEX INCORPORATED AND SHOULD NOT BE USED WITHOUT WRITTEN PERMISSION

9 8 7 6 5 4 3 2 1