8-Bit Serial Input, DMOS Power Driver

Discontinued Product

These parts are no longer in production. The device should not be purchased for new design applications. Samples are no longer available.

Date of status change: April 30, 2007

Recommended Substitutions:

NOTE: For detailed information on purchasing options, contact your local Allegro field applications engineer or sales representative.

Allegro MicroSystems, Inc. reserves the right to make, from time to time, revisions to the anticipated product life cycle plan for a product to accommodate changes in production capabilities, alternative product availabilities, or market demand. The information included herein is believed to be accurate and reliable. However, Allegro MicroSystems, Inc. assumes no responsibility for its use; nor for any infringements of patents or other rights of third parties which may result from its use.

6A595

PRELIMINARY INFORMATION

(Subject to change without notice)

June 11, 2001

8-BIT SERIAL-INPUT, DMOS POWER DRIVER

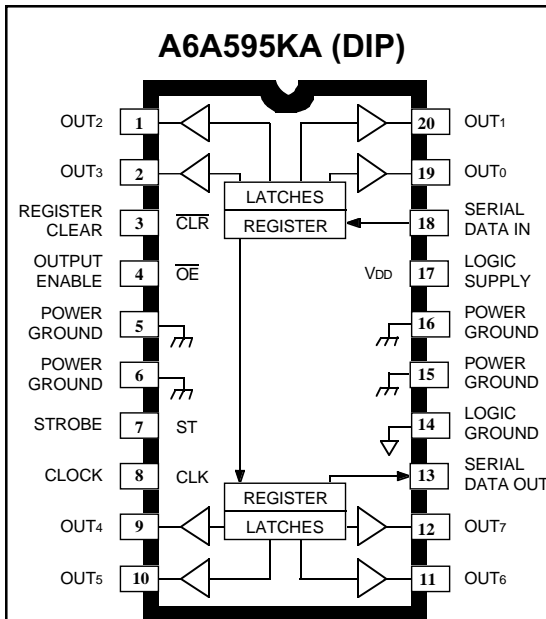

Dwg. PP-029-13

ABSOLUTE MAXIMUM RATINGS at $T_A = 25^\circ\text{C}$

Output Voltage, V_O	50 V
Output Drain Current,	
Continuous, I_O	350 mA*
Peak, I_{OM}	1100 mA†
Single-Pulse Avalanche Energy, E_{AS} ..	75 mJ
Avalanche Current, I_{AS}	600 mA
Source-Drain Diode Current, I_{FM}	2 A
Logic Supply Voltage, V_{DD}	7.0 V
Input Voltage Range, V_I	-0.3 V to +7.0 V
Package Power Dissipation, P_D ...	See Graph
Junction Temperature, T_J	+150°C
Operating Temperature Range,	
T_A	-40°C to +125°C
Storage Temperature Range,	
T_S	-55°C to +150°C

* Each output, all outputs on.

† Pulse duration $\leq 100 \mu\text{s}$, duty cycle $\leq 2\%$.

Caution: These CMOS devices have input static protection (Class 3) but are still susceptible to damage if exposed to extremely high static electrical charges.

The A6A595KA and A6A595KLB combine an 8-bit CMOS shift register and accompanying data latches, control circuitry, and DMOS power driver outputs. Power driver applications include relays, solenoids, and other medium-current or high-voltage peripheral power loads.

The serial-data input, CMOS shift register and latches allow direct interfacing with microprocessor-based systems. Serial-data input rates are over 5 MHz. Use with TTL may require appropriate pull-up resistors to ensure an input logic high.

A CMOS serial-data output enables cascade connections in applications requiring additional drive lines.

The A6A595 DMOS open-drain outputs are capable of sinking up to 500 mA. All of the output drivers are disabled (the DMOS sink drivers turned off) by the OUTPUT ENABLE input high.

The A6A595KA is furnished in a 20-pin dual in-line plastic package. The A6A595KLB is furnished in a 24-lead wide-body, small-outline plastic batwing package (SOIC) with gull-wing leads. Copper lead frames, reduced supply current requirements, and low on-state resistance allow both devices to sink 150 mA from all outputs continuously, to ambient temperatures over 85°C.

FEATURES

- 50 V Minimum Output Clamp Voltage
- 350 mA Output Current (all outputs simultaneously)
- 1 Ω Typical $r_{DS(on)}$
- Internal Short-Circuit Protection
- Low Power Consumption
- Replacements for TPIC6A595N and TPIC6A595DW

Always order by complete part number:

Part Number	Package	$R_{\theta JA}$	$R_{\theta JC}$	$R_{\theta JT}$
A6A595KA	20-pin DIP	55°C/W	25°C/W	—
A6A595KLB	24-lead SOIC	55°C/W	—	6°C/W

6A595

8-BIT SERIAL-INPUT, DMOS POWER DRIVER

A6A595KLB (SOIC)

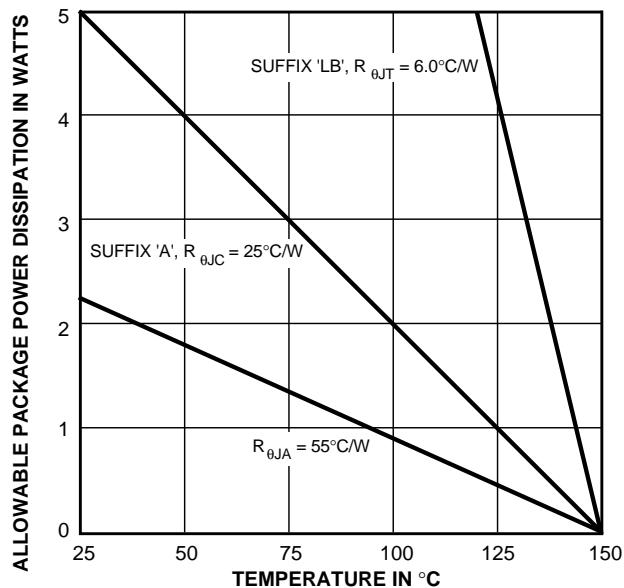

Dwg. GP-049-5

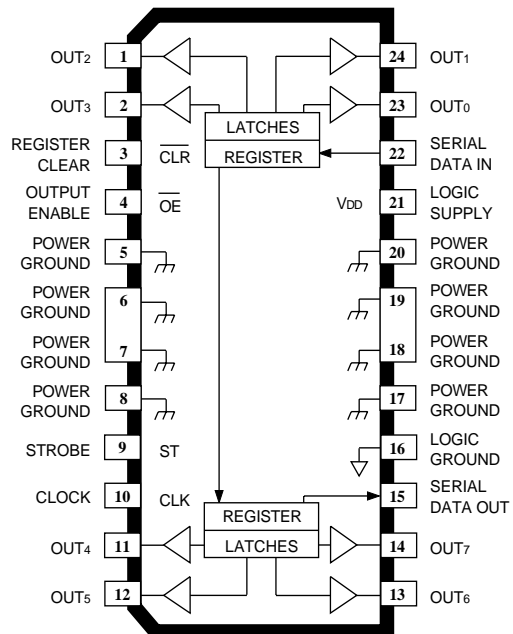

Dwg. PP-029-16A

FUNCTIONAL BLOCK DIAGRAM

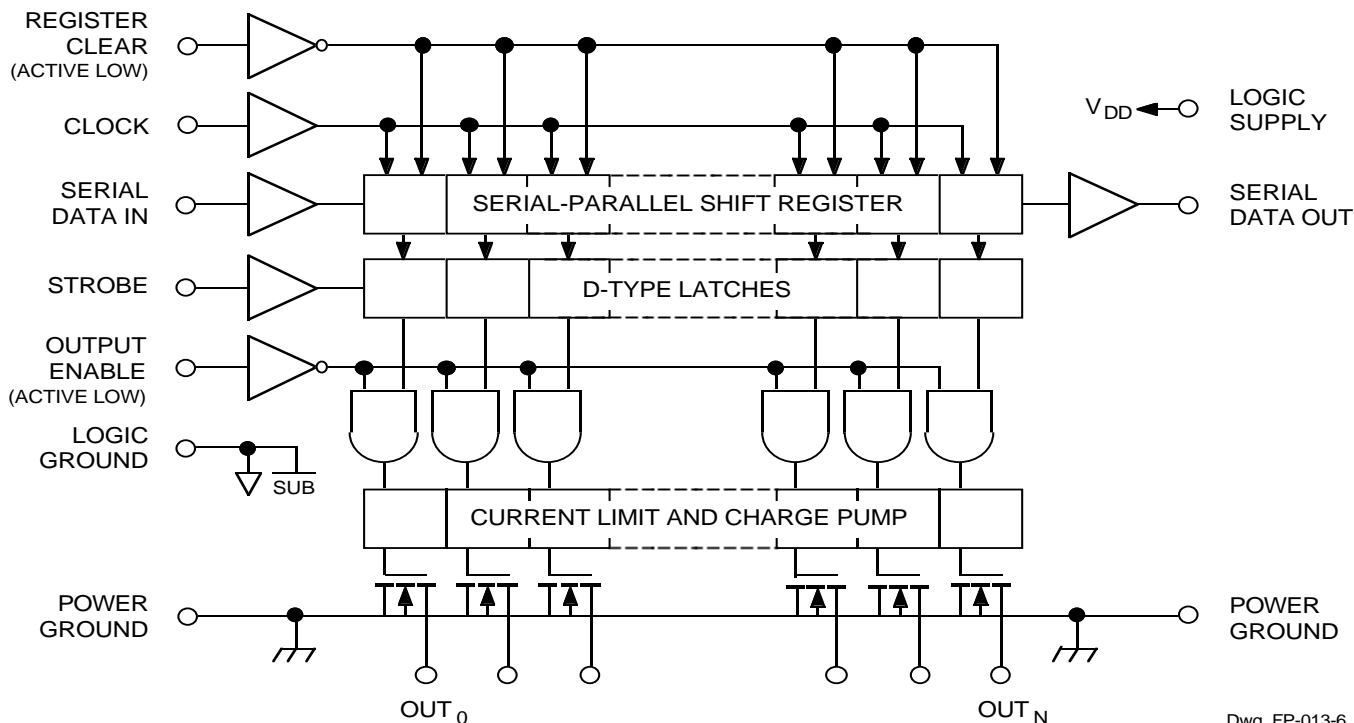

Dwg. FP-013-6

Power grounds must be connected together externally.

6A595

8-BIT SERIAL-INPUT, DMOS POWER DRIVER

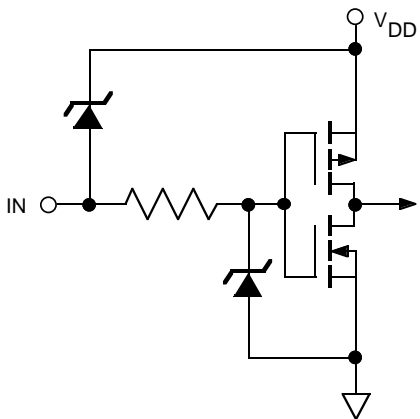

Dwg. EP-010-10

LOGIC INPUTS

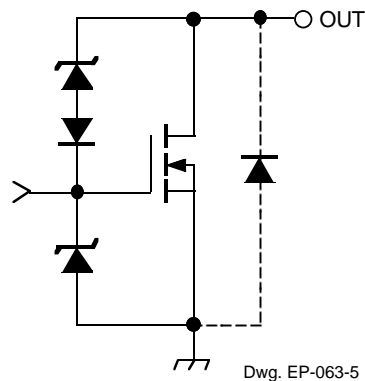

Dwg. EP-063-5

DMOS POWER DRIVER OUTPUT

RECOMMENDED OPERATING CONDITIONS

over operating temperature range

- Logic Supply Voltage Range, V_{DD} 4.5 V to 5.5 V
- High-Level Input Voltage, V_{IH} $\geq 0.85V_{DD}$
- Low-level input voltage, V_{IL} $\leq 0.15V_{DD}$

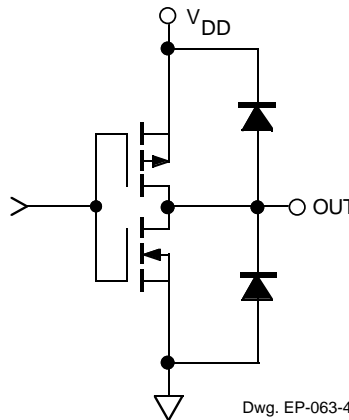

Dwg. EP-063-4

SERIAL DATA OUT

TRUTH TABLE

Data Input	Clock Input	Shift Register Contents						Serial Data Output	Strobe	Latch Contents						Output Enable	Output Contents																				
		l_0	l_1	l_2	...	l_6	l_7			l_0	l_1	l_2	...	l_6	l_7		l_0	l_1	l_2	...	l_6	l_7															
H		H	R_0	R_1	...	R_5	R_6	R_6																													
L		L	R_0	R_1	...	R_5	R_6	R_6																													
X		R_0	R_1	R_2	...	R_6	R_7	R_7																													
		X	X	X	...	X	X	X	—			R_0	R_1	R_2	...	R_6	R_7																				
		P_0	P_1	P_2	...	P_6	P_7	P_7				P_0	P_1	P_2	...	P_6	P_7	L						P_0	P_1	P_2	...	P_6	P_7								
												X	X	X	...	X	X	H						H	H	H	...	H	H								

L = Low Logic Level H = High Logic Level X = Irrelevant P = Present State R = Previous State

6A595

8-BIT SERIAL-INPUT, DMOS POWER DRIVER

ELECTRICAL CHARACTERISTICS at $T_A = +25^\circ\text{C}$, $V_{DD} = 5\text{ V}$, $t_{ir} = t_{if} \leq 10\text{ ns}$ (unless otherwise specified).

Characteristic	Symbol	Test Conditions	Limits			
			Min.	Typ.	Max.	Units
Output Breakdown Voltage	$V_{(BR)DSX}$	$I_O = 1\text{ mA}$	50	—	—	V
Off-State Output Current	I_{DSX}	$V_O = 40\text{ V}$	—	0.1	1.0	μA
		$V_O = 40\text{ V}$, $T_A = 125^\circ\text{C}$	—	0.2	5.0	μA
Static Drain-Source On-State Resistance	$r_{DS(on)}$	$I_O = 350\text{ mA}$	—	1.0	1.5	Ω
		$I_O = 350\text{ mA}$, $T_A = 125^\circ\text{C}$	—	1.7	2.5	Ω
Source-Drain Diode Voltage	V_{SD}	$I_F = 350\text{ mA}$	—	0.9	1.1	V
Nominal Output Current	$I_{O(nom)}$	$V_{DS(on)} = 0.5\text{ V}$, $T_A = 85^\circ\text{C}$	—	350	—	mA
Output Current	$I_{O(chop)}$	I_O at which chopping starts, $T_C = 25^\circ\text{C}$	0.6	0.8	1.1	A
Logic Input Current	I_{IH}	$V_I = V_{DD}$	—	—	1.0	μA
	I_{IL}	$V_I = 0$	—	—	-1.0	μA
SERIAL-DATA Output Voltage	V_{OH}	$I_{OH} = -20\ \mu\text{A}$	4.9	4.99	—	V
		$I_{OH} = -4\text{ mA}$	4.5	4.7	—	V
	V_{OL}	$I_{OL} = 20\ \mu\text{A}$	—	0	0.1	V
		$I_{OL} = 4\text{ mA}$	—	0.3	0.5	V
Prop. Delay Time	t_{PLH}	$I_O = 350\text{ mA}$, $C_L = 30\text{ pF}$	—	100	—	ns
	t_{PHL}	$I_O = 350\text{ mA}$, $C_L = 30\text{ pF}$	—	60	—	ns
Output Rise Time	t_r	$I_O = 350\text{ mA}$, $C_L = 30\text{ pF}$	—	55	—	ns
Output Fall Time	t_f	$I_O = 350\text{ mA}$, $C_L = 30\text{ pF}$	—	40	—	ns
Supply Current	$I_{DD(off)}$	Outputs OFF	—	0.5	5.0	mA
	$I_{DD(fclk)}$	$f_{clk} = 5\text{ MHz}$, $C_L = 30\text{ pF}$, Outputs OFF	—	1.3	—	mA

Typical Data is at $V_{DD} = 5\text{ V}$ and is for design information only.

NOTE — Pulse test, duration $\leq 100\ \mu\text{s}$, duty cycle $\leq 2\%$.

6A595

8-BIT SERIAL-INPUT, DMOS POWER DRIVER

TIMING REQUIREMENTS and SPECIFICATIONS

(Logic Levels are V_{DD} and Ground)

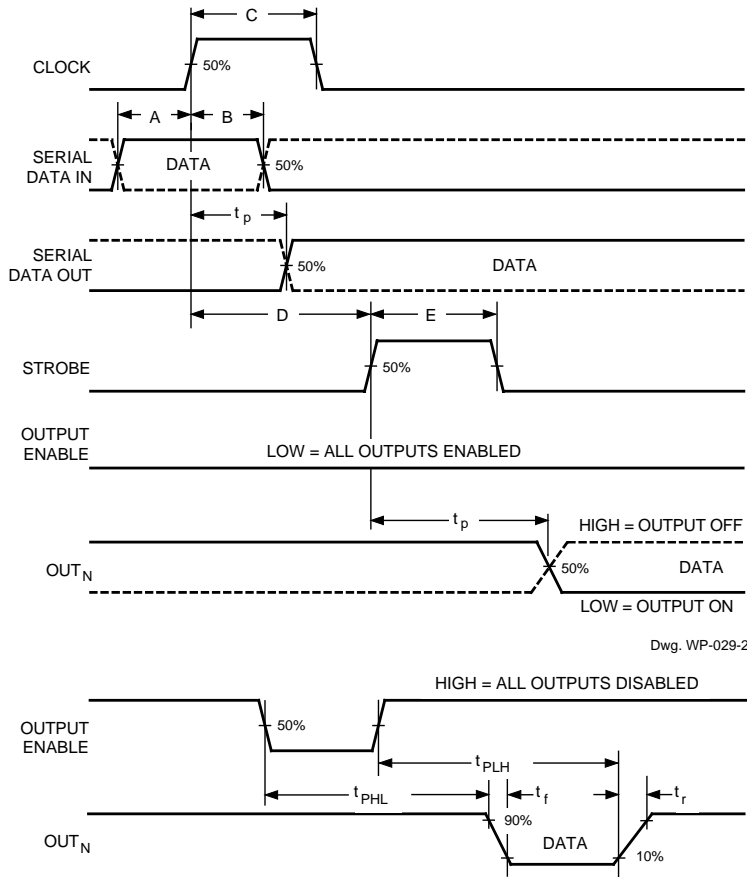

Dwg. WP-029-2

Dwg. WP-030-2

LOGIC SYMBOL

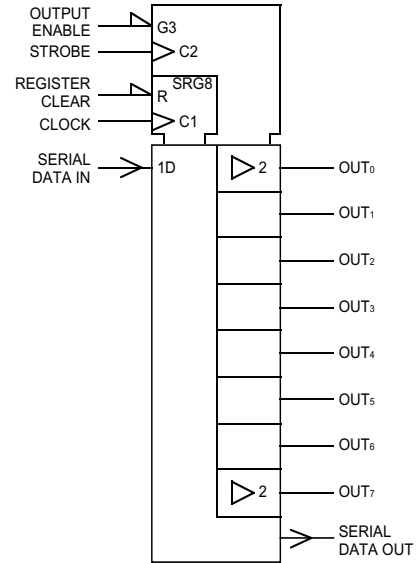

Dwg. FP-043-2

- A.** Data Active Time Before Clock Pulse
(Data Set-Up Time), $t_{su(D)}$ **20 ns**
 - B.** Data Active Time After Clock Pulse
(Data Hold Time), $t_{h(D)}$ **20 ns**
 - C.** Clock Pulse Width, $t_w(CLK)$ **40 ns**
 - D.** Time Between Clock Activation
and Strobe, $t_{su(ST)}$ **50 ns**
 - E.** Strobe Pulse Width, $t_w(ST)$ **50 ns**
 - F.** Output Enable Pulse Width, $t_w(OE)$ **4.5 μ s**
- NOTE – Timing is representative of a 12.5 MHz clock.
Higher speeds are attainable.

Serial data present at the input is transferred to the shift register on the rising edge of the CLOCK input pulse. On succeeding CLOCK pulses, the registers shift data information towards the SERIAL DATA OUTPUT.

Information present at any register is transferred to the respective latch on the rising edge of the STROBE input pulse (serial-to-parallel conversion).

When the OUTPUT ENABLE input is high, the output source drivers are disabled (OFF). The information stored in the latches is not affected by the OUTPUT ENABLE input. With the OUTPUT ENABLE input low, the outputs are controlled by the state of their respective latches.

6A595

8-BIT SERIAL-INPUT, DMOS POWER DRIVER

TEST CIRCUIT

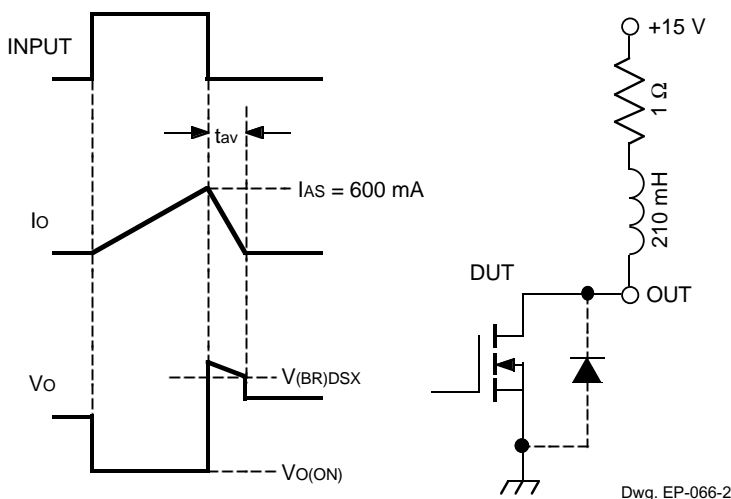

Single-pulse avalanche energy test circuit and waveforms

$$E_{AS} = I_{AS} \times V_{(BR)DSX} \times t_{AV}/2$$

CHOPPING-MODE OPERATION

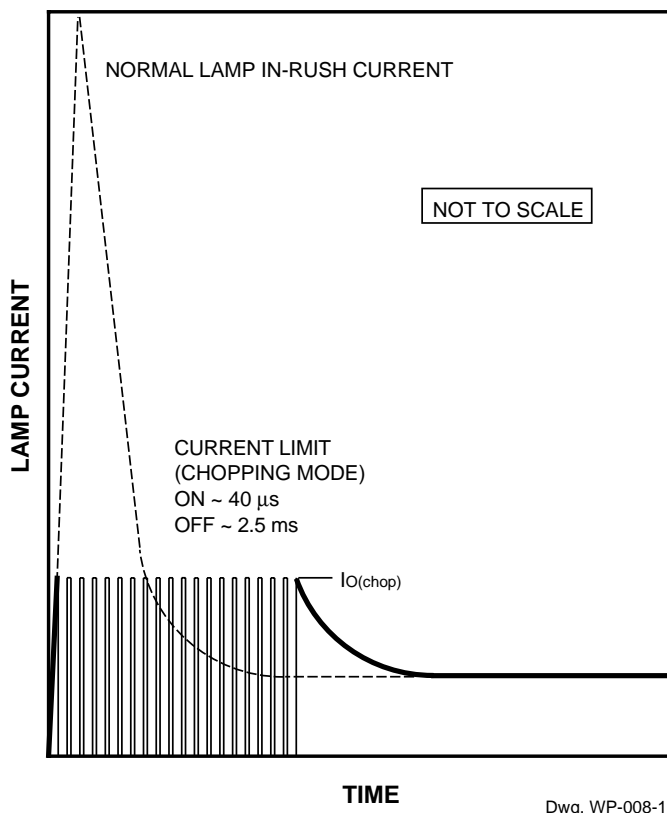

High incandescent lamp turn-on currents (commonly called in-rush currents) can contribute to poor lamp reliability and destroy semiconductor lamp drivers. Warming resistors protect both driver and lamp but use significant power when the lamp is off while current-limiting resistors waste power when the lamp is on. Lamps with steady-state current ratings to 350 mA can be driven by the A6A595 without the need for warming or current limiting resistors.

As shown (the dashed line), when an incandescent lamp is initially turned on, the cold filament is at minimum resistance and will normally allow a 10x peak in-rush current. As the lamp warms up, the filament resistance increases to its rated value and the lamp current is reduced to its steady-state rating. When switching a lamp with the A6A595, the internal chopping circuitry limits the current (the solid line) to $I_{O(chop)}$. The device will stay in the chopping mode until the lamp resistance increases and the current requirement is less than $I_{O(chop)}$. A side-effect of this current-limiting feature is that lamp turn-on time will increase.

6A595

8-BIT SERIAL-INPUT, DMOS POWER DRIVER

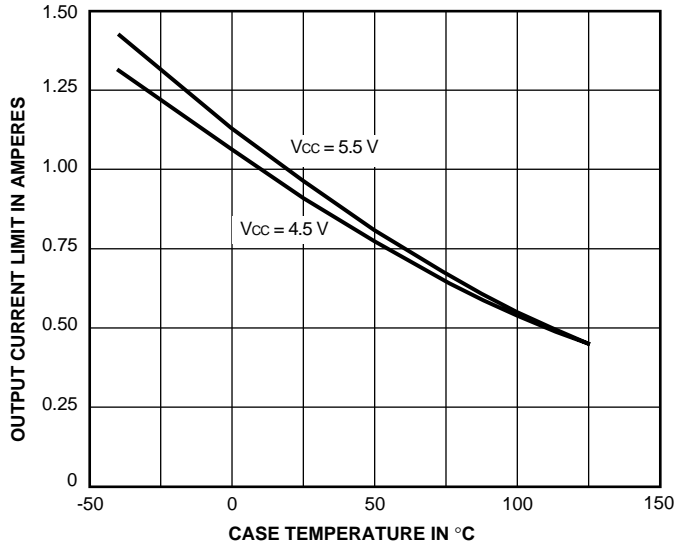

Typical output current limit as a function of case temperature

Dwg. GP-073

TERMINAL DESCRIPTIONS

A6A595KA (DIP) Terminal No.	A6A595KLB (SOIC) Terminal No.	Terminal Name	Function
1-2	1-2	OUT ₂₋₃	Current-sinking, open-drain DMOS output terminals.
3	3	REGISTER CLEAR	When (active) low, the registers are cleared (set low).
4	4	OUTPUT ENABLE	When (active) low, the output drivers are enabled; when high, all output drivers are turned OFF (blanked).
5-6	5-8	POWER GROUND	Reference terminal for output voltage measurements.
7	9	STROBE	Data strobe input terminal; shift register data is latched on rising edge.
8	10	CLOCK	Clock input terminal for data shift on rising edge.
9-12	11-14	OUT ₄₋₇	Current-sinking, open-drain DMOS output terminals.
13	15	SERIAL DATA OUT	CMOS serial-data output to the following shift register.
14	16	LOGIC GROUND	Reference terminal for input voltage measurements.
15-16	17-20	POWER GROUND	Reference terminal for output voltage measurements.
17	21	LOGIC SUPPLY (V _{DD})	The logic supply voltage (typically 5 V).
18	22	SERIAL DATA IN	Serial-data input to the shift-register.
19-20	23-24	OUT ₀₋₁	Current-sinking, open-drain DMOS output terminals.

NOTE — Power grounds must be connected together externally.

6A595

8-BIT SERIAL-INPUT, DMOS POWER DRIVER

A6A595KA

Dimensions in Inches
(controlling dimensions)

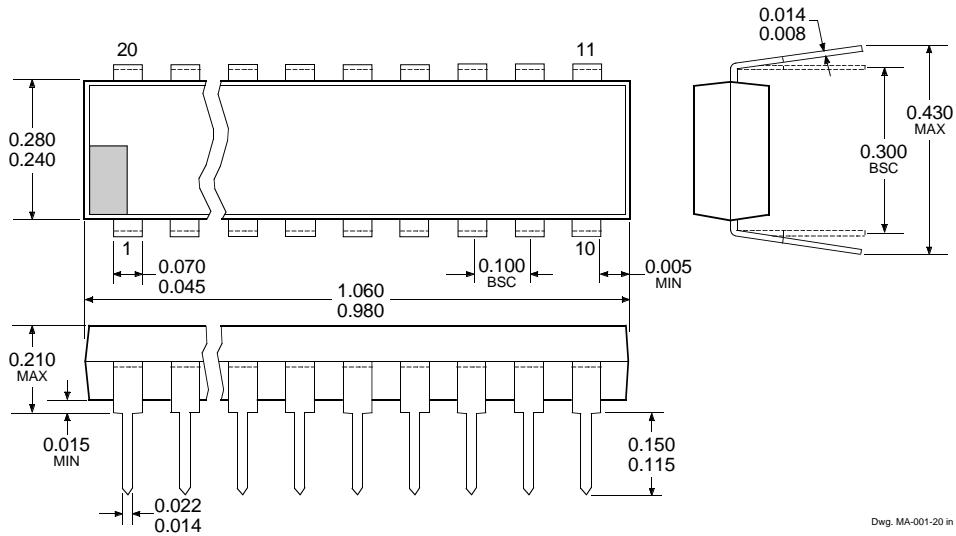

Dimensions in Millimeters (for reference only)

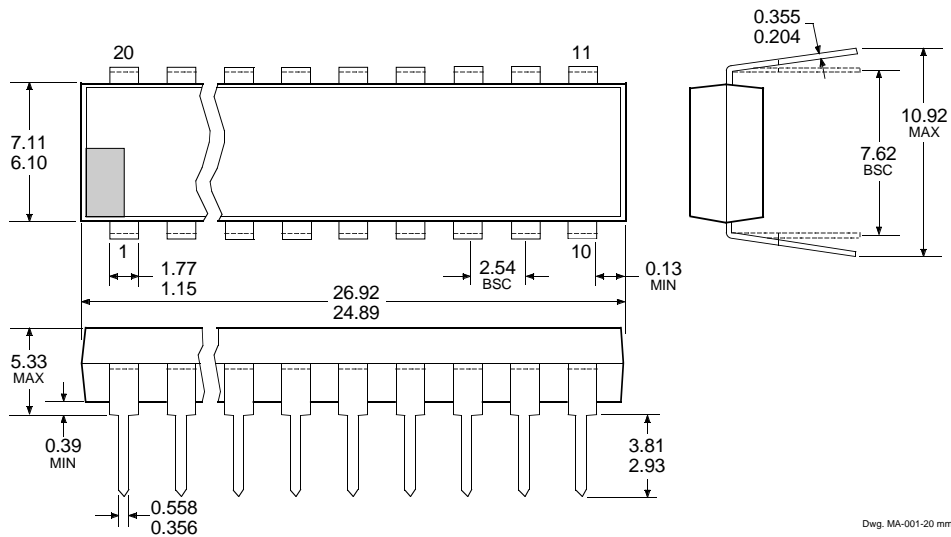

- NOTES: 1. Exact body and lead configuration at vendor's option within limits shown.
 2. Lead spacing tolerance is non-cumulative
 3. Lead thickness is measured at seating plane or below.

6A595

8-BIT SERIAL-INPUT, DMOS POWER DRIVER

A6A595KLB

Dimensions in Inches
(for reference only)

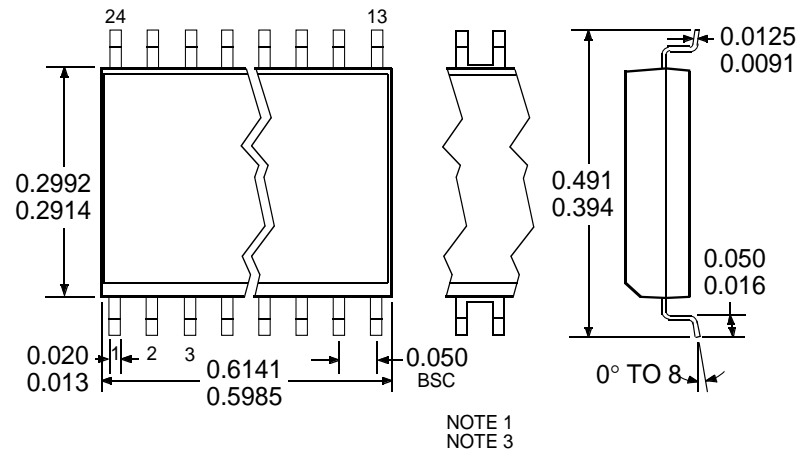

Dwg. MA-008-25 in

Dimensions in Millimeters
(controlling dimensions)

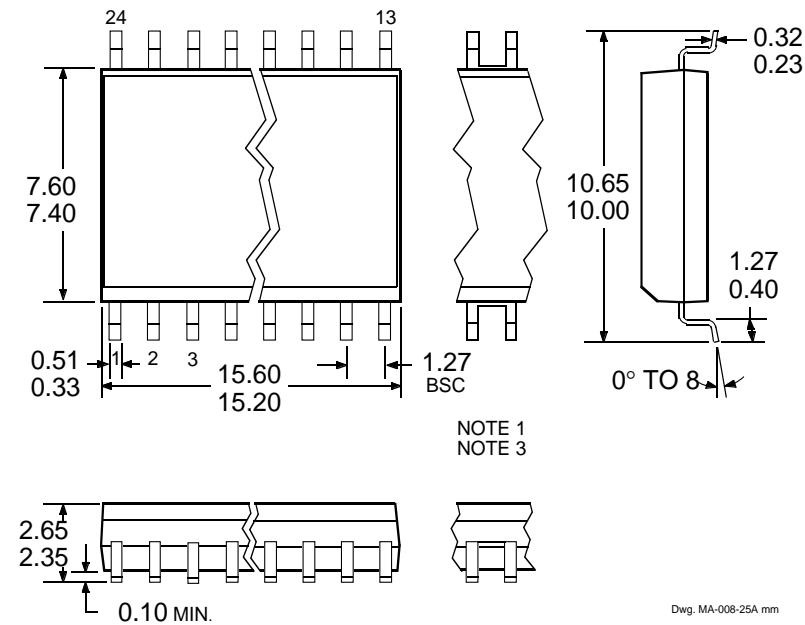

Dwg. MA-008-25A mm

- NOTES: 1. Webbed lead frame. Leads 6, 7, 18, and 19 are internally one piece.
2. Lead spacing tolerance is non-cumulative.
3. Exact body and lead configuration at vendor's option within limits shown.

6A595
8-BIT SERIAL-INPUT,
DMOS POWER DRIVER

The products described here are manufactured under one or more U.S. patents or U.S. patents pending.

Allegro MicroSystems, Inc. reserves the right to make, from time to time, such departures from the detail specifications as may be required to permit improvements in the performance, reliability, or manufacturability of its products. Before placing an order, the user is cautioned to verify that the information being relied upon is current.

Allegro products are not authorized for use as critical components in life-support devices or systems without express written approval.

The information included herein is believed to be accurate and reliable. However, Allegro MicroSystems, Inc. assumes no responsibility for its use; nor for any infringement of patents or other rights of third parties which may result from its use.