

1. MECHANICAL DIMENSIONS :

REV.	DATE	DESCRIPTION
01	Aug.04,16	1st RELEASE

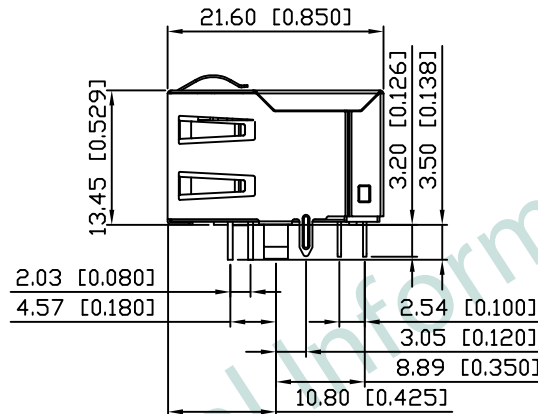

RECOMMENDED PLUG DIMENSION:

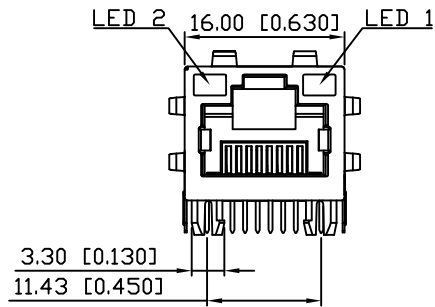
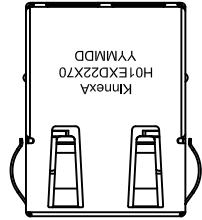
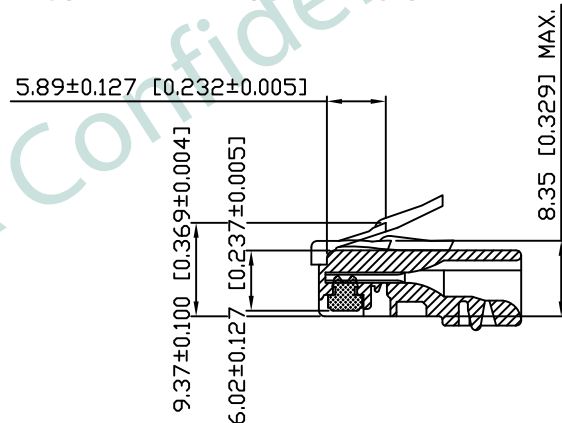

- NOTES:
- MATERIAL:
HOUSING: HIGH TEMPERATURE, NYLON, UL94V-0, COLOR-BLACK
CONTACTS: PHOSPHOR BRONZE, PLATED 6u" GOLD AND TIN ON SOLDER AREA
SHIELD: COPPER ALLOY, PLATED NICKEL.
 - OPERATING TEMPERATURE: -40°C~+85°C
 - INSERTION FORCE: 4 POUNDS MAX.
EXTRACTION FORCE: 4 POUNDS MAX.
 - DURABILITY: 750 MATING CYCLED MIN.
 - CAVITY CONFORMS TO FCC RULES AND REGULATIONS PART 68, SUBPART F.
 - UNSPECIFIED TOLERANCE: .XX ±0.25[0.010]
.X ±0.30[0.012]

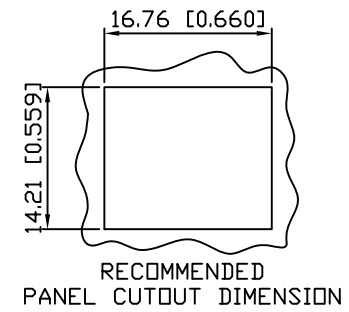

PART NO		KRH-01E-X-D22-X70		
TITLE	RJ45 8P8C, W/ 10/100 TRANSFORMER, W/LED, SHIELDED			
REV : 01				
UNIT	DRAWN	CHKD	DATE	SHEET
mm[inch]	DANIEL	RYAN	Aug.04,16	1 of 5

ROHS Compliant

2. PCB LAYOUT :

3. LED CONFIGURATION :

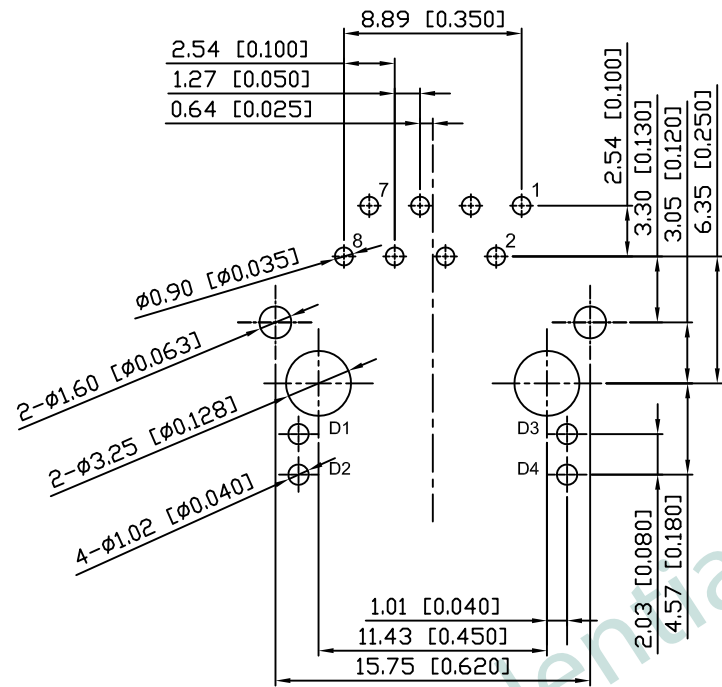

SUGGESTED PCB LAYOUT
(TOP VIEW) SCALE:2:1
DIMENSIONAL TOLERANCE: .XX ±0.08[0.003]

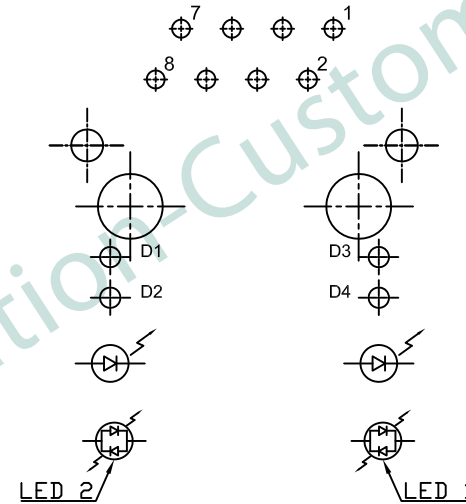

LED Color Options Table

LED Color Options		LED DASH OPTION
Position 2(Left)	Position 1(Right)	
Yellow	Green	1
Green	Yellow	4
Green	Green	5
Yellow/Green	Yellow/Green	8
Green/Yellow	Green/Yellow	A
Green	Green/Yellow	D
Yellow	Green/Yellow	E
Green/Yellow	Green	H

 PART NO KRH-01E-X-D22-X70

TITLE	RJ45 8P8C, W/ 10/100 TRANSFORMER, W/LED, SHIELDED			
REV : 01				
UNIT	DRAWN	CHKD	DATE	SHEET
mm[inch]	DANIEL	RYAN	Aug.04,16	2 of 5

4. SCHEMATIC :

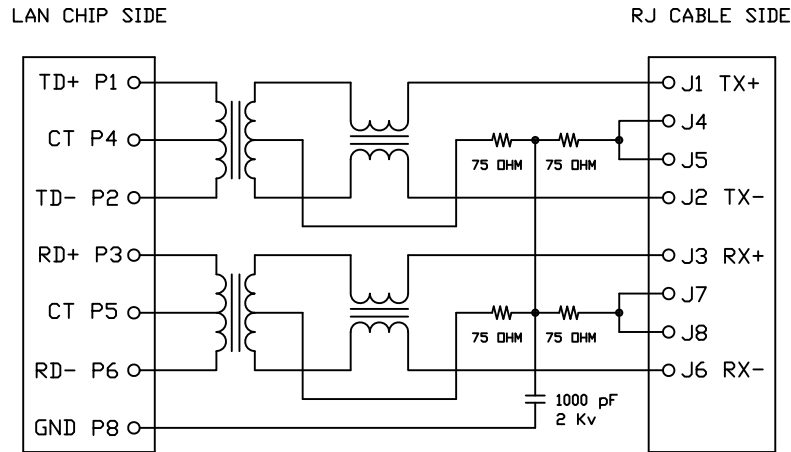

5. ELECTRICAL CHARACTERISTICS :

TEST NOTES:($25 \pm 5^\circ\text{C}$)

- 1.TR:
INPUT TO OUTPUT= $1:1 \pm 3\%$
- 2.LX:(100KHz,100mV,8mA, DC Bias)
350uH MINIMUM
- 3.DCR:
EVERY RJ PAIR= 1.2Ω MAXIMUM
- 4.HIPOT:
INPUT TO OUTPUT PIN: 1500 VAC/60SEC
- 5.INSERTION LOSS:
-0.8dB MAXIMUM AT 0.3MHz TO 100MHz
-1.2dB MAXIMUM AT 100MHz TO 125MHz
- 6.RETURN LOSS:
-20dB MINIMUM AT 1MHz TO 10MHz
-16dB MINIMUM AT 30MHz
-12dB MINIMUM AT 60MHz TO 100MHz
- 7.CROSS TALK:
-40dB MINIMUM AT 1MHz TO 10MHz
-35dB MINIMUM AT 30MHz TO 60MHz
-30dB MINIMUM AT 60MHz TO 100MHz
- 8.COMMON TO COMMON MODE REJECTION:
-30dB MINIMUM AT 300KHz TO 100MHz

KRH-01E-X-D22-X70

PRODUCT SERIES
KRH: LATCH UP

MECHANICAL TYPE
01E: KRH 1 PORT, LENGTH=21.3mm,
STAGGERED PINS
LED COLOR OPTION

CIRCUIT TYPE

SPECIAL CODE
0: STANDARD

SHIELDED TYPE
7: EMI FINGER ON ALL SIDE
LED POLARITY

PART NO		KRH-01E-X-D22-X70		
TITLE	RJ45 8P8C, W/ 10/100 TRANSFORMER, W/LED, SHIELDED			
REV : 01				
UNIT	DRAWN	CHKD	DATE	SHEET
mm[inch]	DANIEL	RYAN	Aug.04,16	3 of 5

6. PACKING SPECIFICATION:

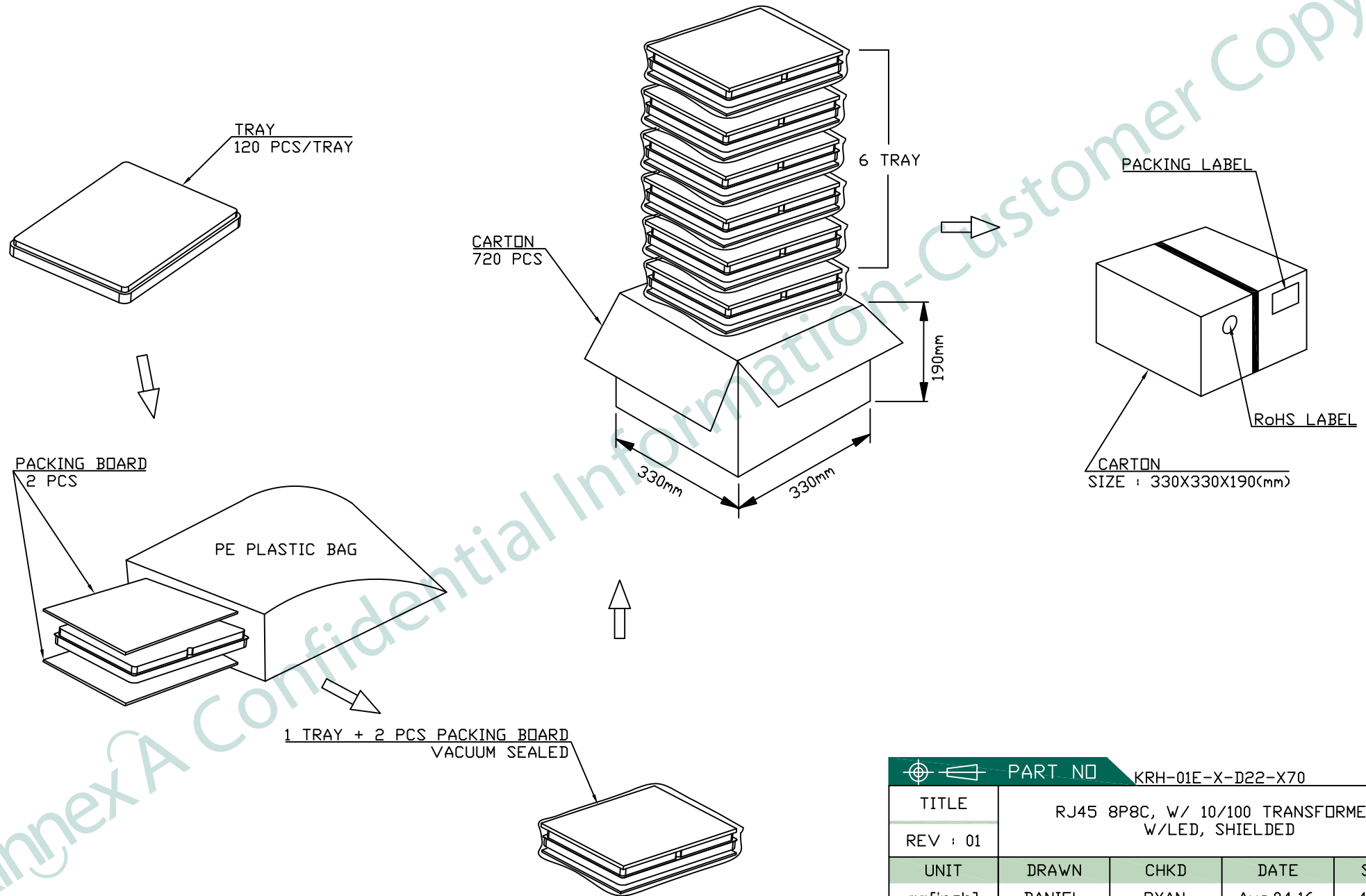

 PART NO KRH-01E-X-D22-X70				
TITLE	RJ45 8P8C, W/ 10/100 TRANSFORMER, W/LED, SHIELDED			
REV : 01				
UNIT	DRAWN	CHKD	DATE	SHEET
mm[inch]	DANIEL	RYAN	Aug.04,16	4 of 5

RoHS Compliant

7. PROFILE OF WAVE SOLDER :

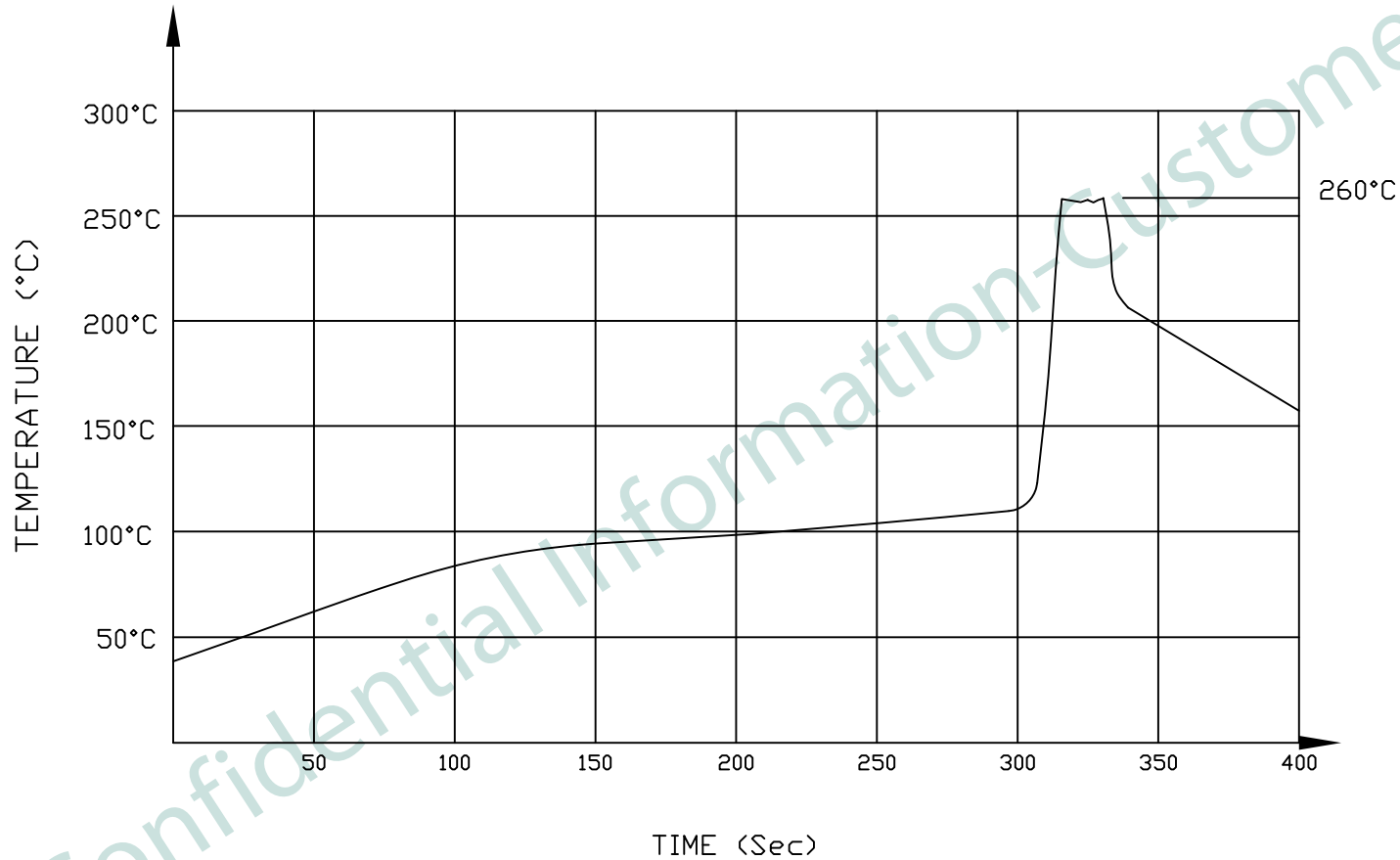

SUGGESTED WAVE SOLDER CURVE

(1) TIP temperature : $260 \pm 5^\circ\text{C}$

(2) TIP temperature time : 10Sec. Max.

 PART NO KRH-01E-X-D22-X70				
TITLE	RJ45 8P8C, W/ 10/100 TRANSFORMER, W/LED, SHIELDED			
REV : 01				
UNIT	DRAWN	CHKD	DATE	SHEET
mm[inch]	DANIEL	RYAN	Aug.04,16	5 of 5