

FEATURES

Isolated Current Input.

Amplifies, Protects, Filters, and Isolates Analog Input.

Measure process-current input signal of 4-20 mA or 0-20 mA by reading the voltage across an external precision 20Ω resistor (supplied).

Generates an output of 0 to +5V.

Extra Current Conversion resistors are available.

Module circuitry can withstand 240v rms at the input screw-terminals.

All 5B32 series modules are mix-and-match and Hot Swappable.

APPLICATIONS

Industrial signal conditioning

Industrial signal isolation

Industrial signal filtering

PRODUCT OVERVIEW

The 5B Series represents an innovative generation of low cost, high performance plug-in signal conditioners. Designed for industrial applications, these modules incorporate highly reliable transformer-based isolation and automated surface-mount manufacturing technology. They are compact, economical components whose performance exceeds that available from more expensive devices. Combining 1500 V rms continuous isolation, +0.05% calibrated accuracy, small size and low cost, the 5B Series is an attractive alternative to expensive signal conditioners and in-house designs

All modules are potted and identical in pin-out and size (2.27" x 2.32" x 0.595"). They can be mixed and matched, permitting users to address their exact needs, and may be "hot swapped" without disturbing field wiring or power. The isolated input modules provide 0 to +5V or +5V outputs and accept J, K, T, E, R, S, N, or B type thermocouples.

These modules feature complete signal conditioning functions including 240 V rms input protection, filtering, chopper stabilized low drift +1 uV/oC amplification, 1500 V rms isolation, and sensor excitation when required.

All modules feature excellent common mode rejection and meet industrial transient surge withstand specifications.

Rev. 0

Information furnished by Analog Devices is believed to be accurate and reliable. However, no responsibility is assumed by Analog Devices for its use, nor for any infringements of patents or other rights of third parties that may result from its use. Specifications subject to change without notice. No license is granted by implication or otherwise under any patent or patent rights of Analog Devices. Trademarks and registered trademarks are the property of their respective companies.

FUNCTIONAL BLOCK DIAGRAM

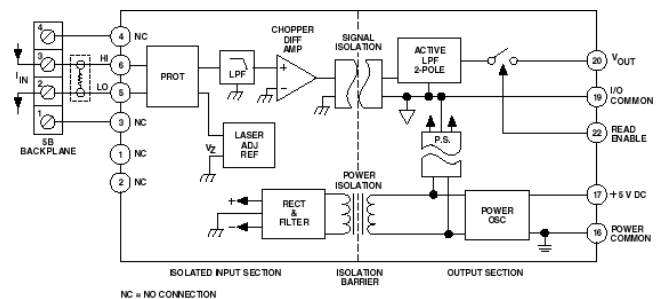

Figure 1. 5B32 Functional Block Diagram

There are also a number of backplanes and mounting sockets which provide a complete signal conditioning solution for end users. Each backplane incorporates screw terminals for field wiring inputs and outputs and cold junction sensors for thermocouple applications.

These signal conditioners are designed to provide an easy and convenient solution to signal conditioning problems of both designers and end users in measurement and control applications. Typical uses include microcomputer-based measurement systems, standard data acquisition systems, programmable controllers, analog recorders and dedicated control systems. The 5 B series modules are ideally suited to applications where monitoring and control of temperature, pressure, flow, rotation and other analog signals are required.

The 5B Series modules and backplanes are approved by Factory Mutual (FM) and the 5B Series modules are approved by the Canadian Standards Association (CSA) for use in Class 1, Division 2, Groups A, B, C, and D locations. These approvals certify that the 5B Series is suitable for use in locations where a hazardous concentration of flammable gas may exist only under fault conditions of operation. Equipment of this category is called "nonincendive" and they need no special enclosures or other physical safeguards.

The 5B series modules and backplanes have been tested and passed the stringent heavy industrial requirements of the European Union's electromagnetic compatibility (EMC) directive – EN50082-1 and EN50081-2. When used according to installation directions (refer to 5B series User Manual), any errors caused by EMI/RFI interference will be less than 0.1% of the full scale 5B measurement range for field strengths up to 10 V/M and frequencies up to 1 GHz.

GENERAL DESCRIPTION

The 5B32 is a single-channel signal conditioning module that amplifies, protects, filters and isolates its analog input. The module measures a process current input signal of 4-20 mA or 0-20 mA by reading the voltage across an external precision 20W resistor (supplied) and generating an output of 0 to +5 V. Extra current conversion resistor are available as accessories (See Model AC1362 in the Accessories section).

Note that the 5B32 module circuitry can withstand 240 V rms at the input screw-terminals, thereby shielding computer-side circuitry from field-side overvoltage conditions. In addition, all 5B32 Series modules are mix-and-match and hot swappable, so can be inserted or removed from any socket in the same backplane without powering down the system.

A chopper-stabilized input amplifier provides low drift and stable gain. At the amplifier input, a stable, laser-trimmed zero-scale input offset is subtracted from the input signal to set the

zero-scale value for the 4-20 mA range. For user convenience, the zero can be optionally factory-set to meet custom needs. This allows suppression of a zero-scale input value many times larger than the total span for precise expanded-scale measurements.

Internal multi-pole lowpass filtering with a four-Hz cutoff (-3dB) enhances normal-mode (noise on signal) and common-mode (noise on signal return) rejection at 50/60 Hz, enabling accurate measurement of small signals in high electrical noise.

A series output switch eliminates the need for external multiplexing in many applications. The switch is turned on by an active-low enable input. If the switch is to be on at all times, the enable-input should be grounded to power common as it is on the 5B01 and 5B08 backplanes..



Figure 2

5B32—SPECIFICATIONS

5B32 Specifications

| | |
|---|---|
| Standard Ranges | 0 mA to 20 mA or 4 mA to 20 mA |
| Custom Ranges | 0 mA to 20 mA (refer to ordering section) |
| Output Ranges ($R_L > 50 \text{ k}\Omega$)⁴ | -5 V to +5 V or 0 V to +5 V |
| Initial @ +25°C | $\pm 0.05\%$ Span $\pm 0.05\%$ I_z ¹ |
| Nonlinearity | $\pm 0.02\%$ Span |
| Input Offset vs. Temperature | ± 0.0025 of $I_z/^\circ\text{C}$ |
| Output Offset vs. Temperature | $\pm 20 \mu\text{V}/^\circ\text{C}$ |
| Gain vs. Temperature | $\pm 0.0025\%$ of Reading/ $^\circ\text{C}$ |
| Value | 20.0 Ω |
| Accuracy | $\pm 0.1\%$ |
| Stability vs. Temperature | $\pm 0.001\%/^\circ\text{C}$ |
| Input, 0.1 Hz to 10 Hz Bandwidth | 10 nA rms |
| Output, 100 kHz Bandwidth | 200 μV rms |
| Bandwidth, -3 dB | 4 Hz |
| Output Rise Time, 10% to 90% Span | 200 ms |
| Input-to-Output, Continuous | 1500 V rms maximum |
| Output-to-Power, Continuous | ± 3 V maximum |
| Transient | ANSI/IEEE C37.90.1-1989 |
| 1 $\text{k}\Omega$ Source Imbalance, 50/60 Hz | 160 dB |
| Normal Mode Rejection 50/60 Hz | 60 dB |
| Continuous | 240 V rms maximum |
| Transient | ANSI/IEEE C37.90.1-1989 |
| Output Resistance ⁴ | 50 Ω |
| Voltage Output Protection | Continuous Short to Ground |
| Output Selection Time | 6 μs @ $C_{\text{load}} = 0$ to 2,000 pF |
| Max Logic "0" | +1 V |

| | |
|-------------------------------|---|
| Min Logic "1" | +2.5 V |
| Max Logic "1" | +36 V |
| Input Current "0" | 0.4 mA |
| Power Supply Voltage | +5 V \pm 5% |
| Power Supply Current | 30 mA |
| Power Supply Sensitivity, RTI | \pm 2 μ V/Vs% |
| Mechanical Dimensions | 2.275" x 2.375" x 0.595" (57.8 mm x 59.1 mm x 15.1 mm) |
| Temperature Range | |
| Rated Performance | -25°C to +85°C |
| Operating | -40°C to +85°C |
| Storage | -40°C to +85°C |
| Relative Humidity | 0 to 93% @ +40°C noncondensing |
| RFI Susceptibility | \pm 0.5% Span error @ 400 MHz, 5 Watt, 3 ft |

1 I_2 is the nominal input current that results in a 0 V output.

2 Includes the combined effects of repeatability, hysteresis, and nonlinearity and assumes $R_L > 50 \text{ k}\Omega$. Does not include current-to-voltage input resistor (AC1362) error.

3 The output common must be kept within $\pm 3 \text{ V}$ of power common.

4 Loads heavier than $50 \text{ k}\Omega$ will degrade nonlinearity and gain temperature coefficient.

5 The current-to-voltage conversion resistor (AC1362) is supplied as a plug-in component for mounting external to the module. All backplanes and mounting cards provide pin sockets for mounting the AC1362 resistor.

Specifications subject to change without notice.

PIN CONFIGURATIONS AND FUNCTIONAL DESCRIPTIONS

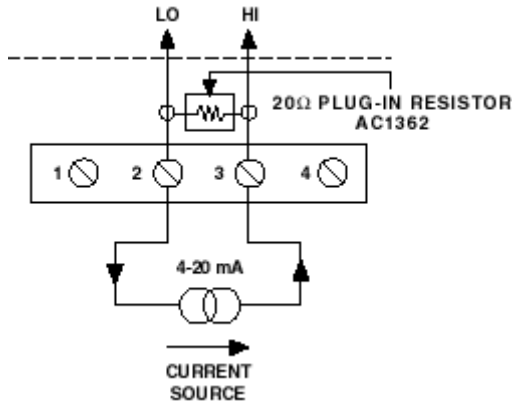

Figure 3 5B32 Input Field Connections

Table 1. Pin Function Descriptions—

| Pin No. | Description |
|---------|--------------------------------|
| 1 | SENSOR - |
| 2 | SENSOR + |
| 3 | EXCITATION - |
| 4 | EXCITATION + |
| 5 | INPUT LO |
| 6 | INPUT HI |
| 16 | POWER COM |
| 17 | +5V DC |
| 18 | V _{IN} (5B39 ONLY) |
| 19 | I/O COM |
| 20 | V _{OUT} (EXCEPT 5B39) |
| 21 | RESERVED |
| 22 | READ ENABLE (0) |
| 23 | WRITE ENABLE (0) |

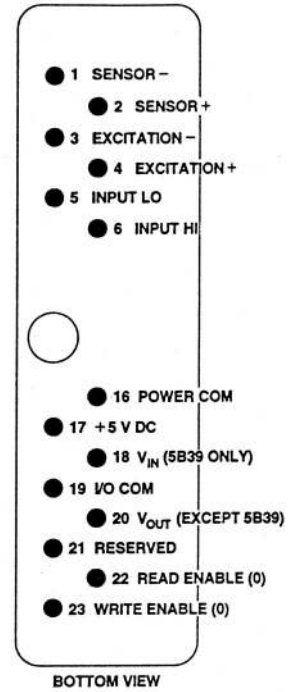
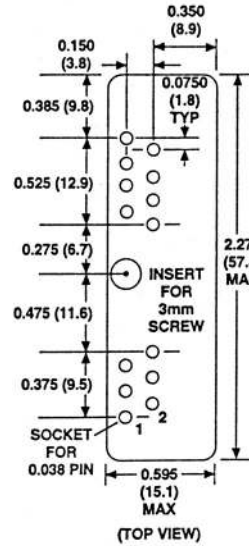

Figure 4 . Model 5B Series Module, with pin-out assignments.

ESD CAUTION

ESD (electrostatic discharge) sensitive device. Electrostatic charges as high as 4000 V readily accumulate on the human body and test equipment and can discharge without detection. Although this product features proprietary ESD protection circuitry, permanent damage may occur on devices subjected to high energy electrostatic discharges. Therefore, proper ESD precautions are recommended to avoid performance degradation or loss of functionality.



NOTES

NOTES