

QT-Brightek Optocoupler Series

5-PIN 1 Mbit/s High Speed Transistor Coupler

Part No.: QTM452, 453

Product: QTM452_453	Date: February 12, 2018	Page 1 of 15
	Version# 1.0	

Table of Contents:

Introduction	3
Absolute Maximum Rating	4
Electrical Characteristic ($T_A=25^\circ\text{C}$)	5
Characteristic Curves.....	7
Test Circuits	9
Solder Profile & Footprint.....	11
Packing & Labeling	13
Device Marking	14
Ordering Information	14
Revision History	15
Disclaimer	15

Introduction

Feature:

- High Speed 1Mbit/s
- High Isolation voltage between input and output (Viso = 3750V rms)
- Guaranteed CTR performance from 0 °C to 70 °C
- Mini-Flat package

Certification & Compliance:

- Pb free and RoHS Compliant
- UL recognized (File #E338132)
- cUL recognized (File #E338132)
- VDE (Pending Approval)

Schematic:

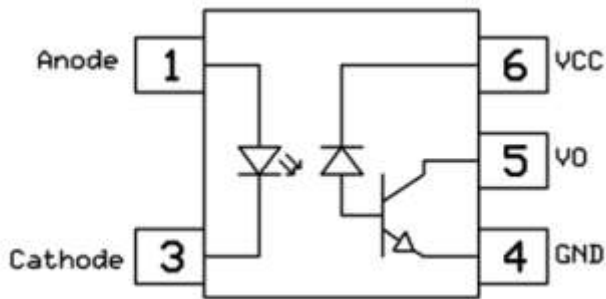

Dimension: (Dot location indicates pin 1)

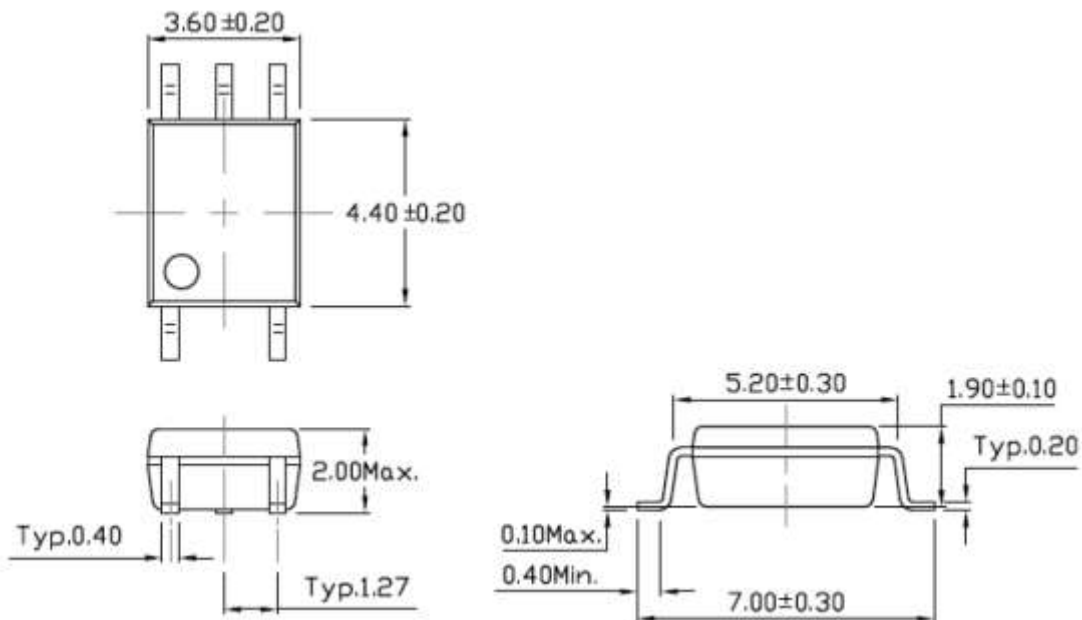

All Dimensions are in mm

Absolute Maximum Rating

Symbol	Parameter	Rating	Units
V _{ISO}	Isolation Voltage	3750	V _{RMS}
T _{STG}	Storage Temperature	-55 ~ +125	°C
T _{OPR}	Operating Temperature	-55 ~ +100	°C
T _{SOL}	Lead Solder Temperature	260 for 10 sec	°C
EMITTER			
I _F	Continuous Forward Current	25	mA
I _{FP}	Peak Forward Current (50% duty, 1ms P.W)	50	mA
I _{FP(TRANS)}	Peak transient Current (≤ 1us P.W, 300pps)	1	A
V _R	Reverse Voltage	5	V
P _D	Power Dissipation	45	mW
	Power Dissipation Derated above 100°C	-	mW/°C
DETECTOR			
P _D	Power Dissipation	100	mW
I _{O(AVG)}	Average Output current	8	mA
I _{O(Peak)}	Peak Output current	16	mA
VO	Output voltage	-0.5 to 20	V
VCC	Supply voltage	-0.5 to 30	V

Electrical Characteristic (T_A=25 °C)

Emitter

Symbol	Characteristics	Device	Test Condition	Range			Unit
				Min	Typ	Max	
V _F	Forward Voltage	-	I _F = 16mA	-	1.45	1.6	V
V _R	Reverse Voltage		I _R = 10μA	5	-	-	V
ΔV _F /ΔT _A	Temperature coefficient of forward voltage		I _F = 16mA	-	-1.6	-	mV/°C

Detector

Symbol	Characteristic	Device	Test Condition	Range			Unit
				Min	Typ	Max	
I _{OH}	Logic High Output Current	-	I _F =0mA, V _O =V _{CC} =5.5V, T _A =25°C	-	0.001	0.5	μA
			I _F =0mA, V _O =V _{CC} =15V, T _A =25°C	-	0.01	1	
			I _F =0mA, V _O =V _{CC} =15V	-	-	50	
I _{CCL}	Logic Low Supply Current	-	I _F =16mA, V _O =Open, V _{CC} =15V	-	120	200	μA
I _{CCH}	Logic High Supply Current	-	I _F =0mA, V _O =Open, V _{CC} =15V, T _A =25°C	-	0.01	1	μA
			I _F =0mA, V _O =Open, V _{CC} =15V	-	-	2	

Transfer Characteristics (T_A=0 to 70C unless specified otherwise)

Symbol	Characteristic	Device	Test Condition	Range			Unit
				Min	Typ	Max	
CTR	Current Transfer Ratio		I _F =16mA, V _O =0.4V, V _{CC} =4.5V, T _A =25°C	20	-	50	%
			I _F =16mA, V _O =0.5V, V _{CC} =4.5V	15	-	-	
V _{OL}	Logic Low Output Voltage		I _F =16mA, I _O =3mA, V _{CC} =4.5V, T _A =25°C	-	-	0.4	V
			I _F =16mA, I _O =2.4mA, V _{CC} =4.5V	-	-	0.5	Ω

Switching Characteristics (TA=25°C, Vcc=5V)

Symbol	Characteristic	Device	Test Condition	Range			Unit
				Min	Typ	Max	
T _{PHL}	Propagation Delay Time Logic High to Logic Low		I _F =16mA, R _L =1.9KΩ, T _A =25°C	-	0.3 5	0.8	μs
			I _F =16mA, R _L =1.9KΩ	-	-	1.0	
T _{PLH}	Propagation Delay Time Logic Low to Logic High		I _F =16mA, R _L =1.9KΩ, T _A =25°C	-	0.3	0.8	μs
			I _F =16mA, R _L =1.9KΩ	-	-	1.0	
CM _H	Common Mode Transient Immunity at Logic High	CTM452	I _F = 0mA, V _{CM} =10Vp-p, R _L =1.9KΩ, T _A =25°C	5000	-	-	V/μs
		CTM453	I _F = 0mA, V _{CM} =1500Vp-p, R _L =1.9KΩ, T _A =25°C	15000	-		
CM _L	Common Mode Transient Immunity at Logic Low	CTM452	I _F = 0mA, V _{CM} =10Vp-p, R _L =1.9KΩ, T _A =25°C	5000	-	-	V/μs
		CTM453	I _F = 0mA, V _{CM} =1500Vp-p, R _L =1.9KΩ, T _A =25°C	15000	-		

Characteristic Curves

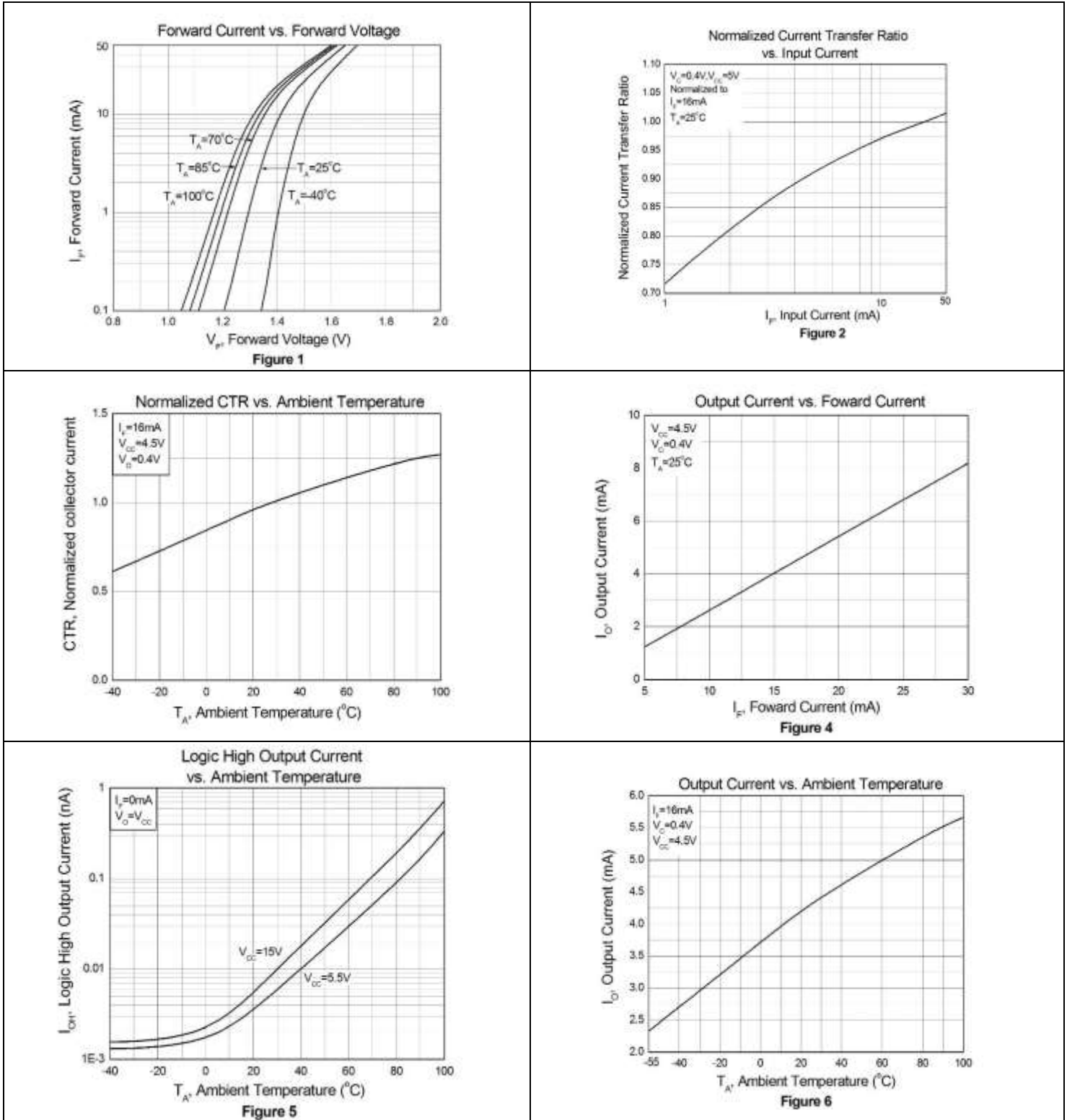

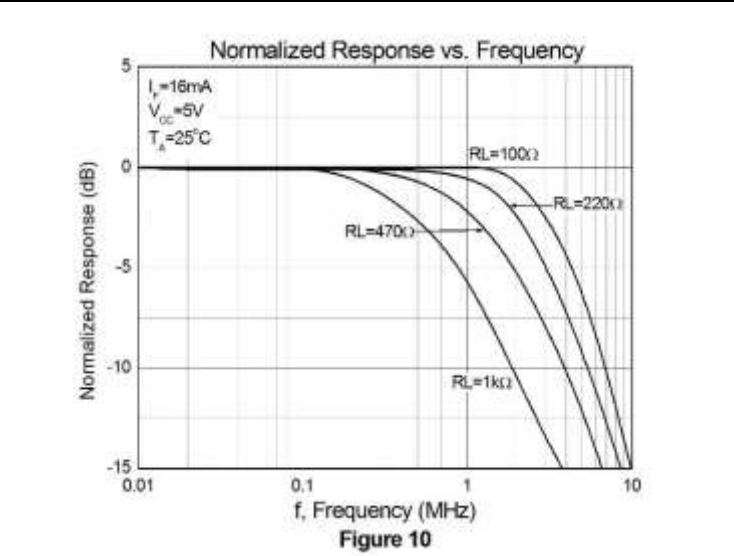
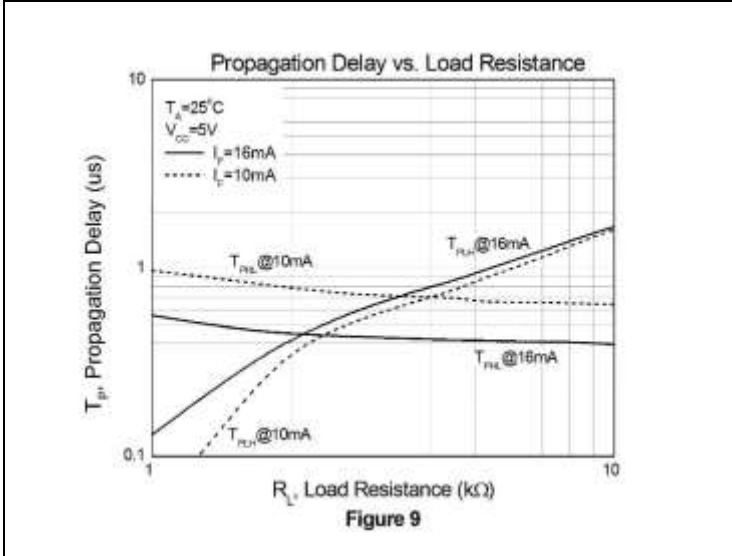
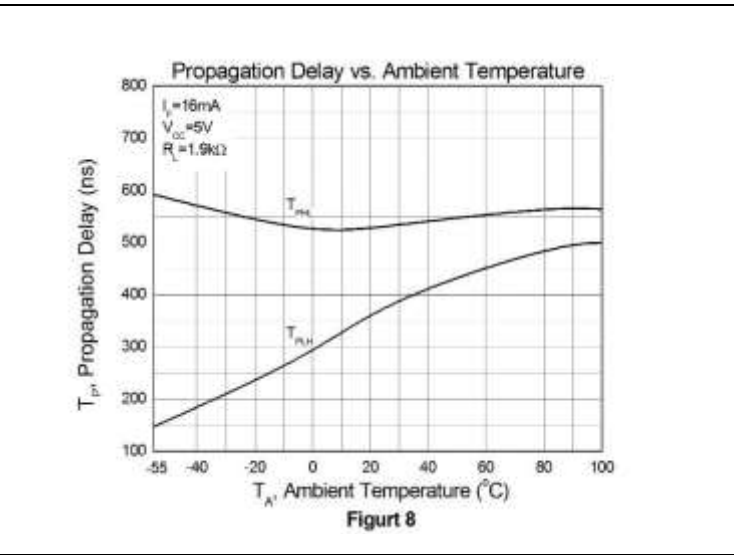
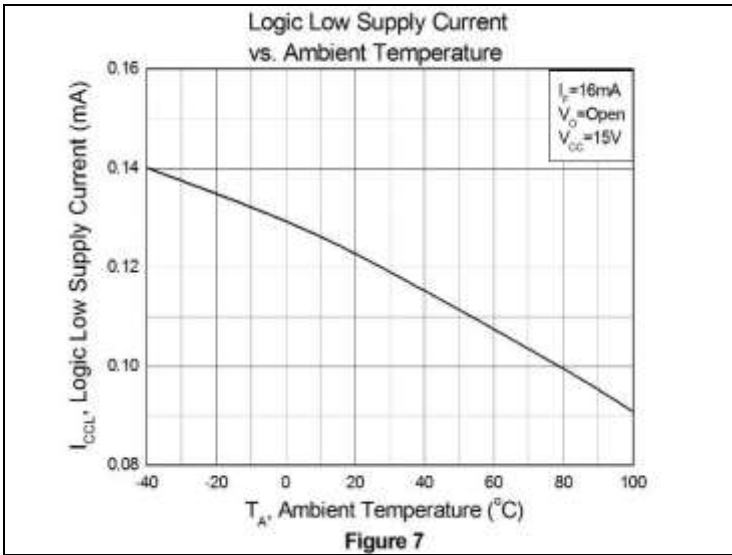

--	--

Test Circuits

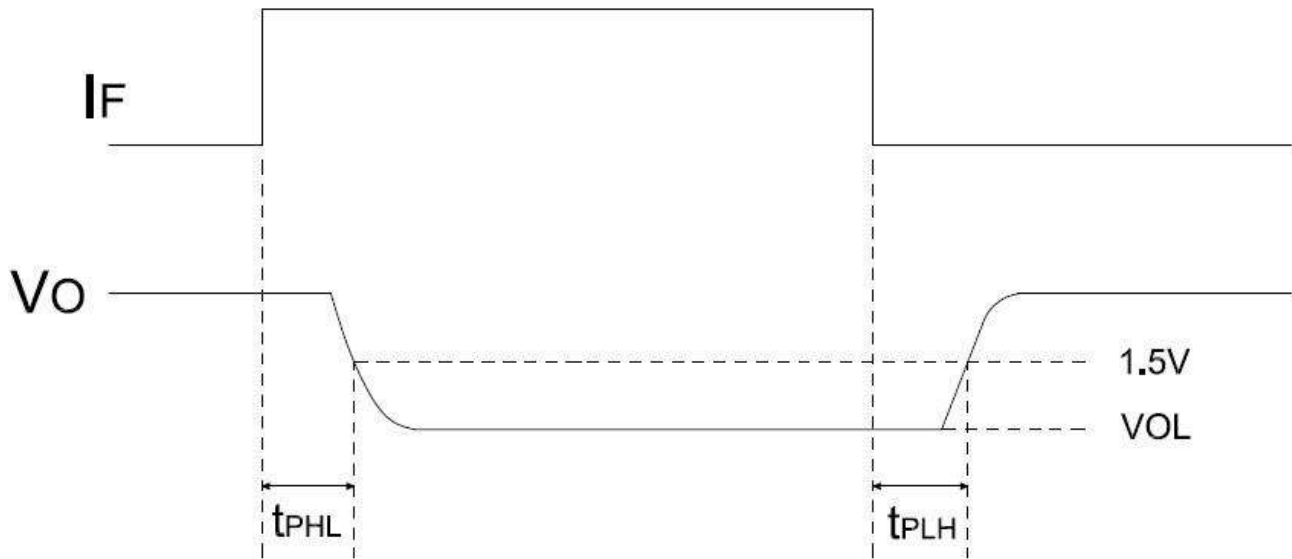
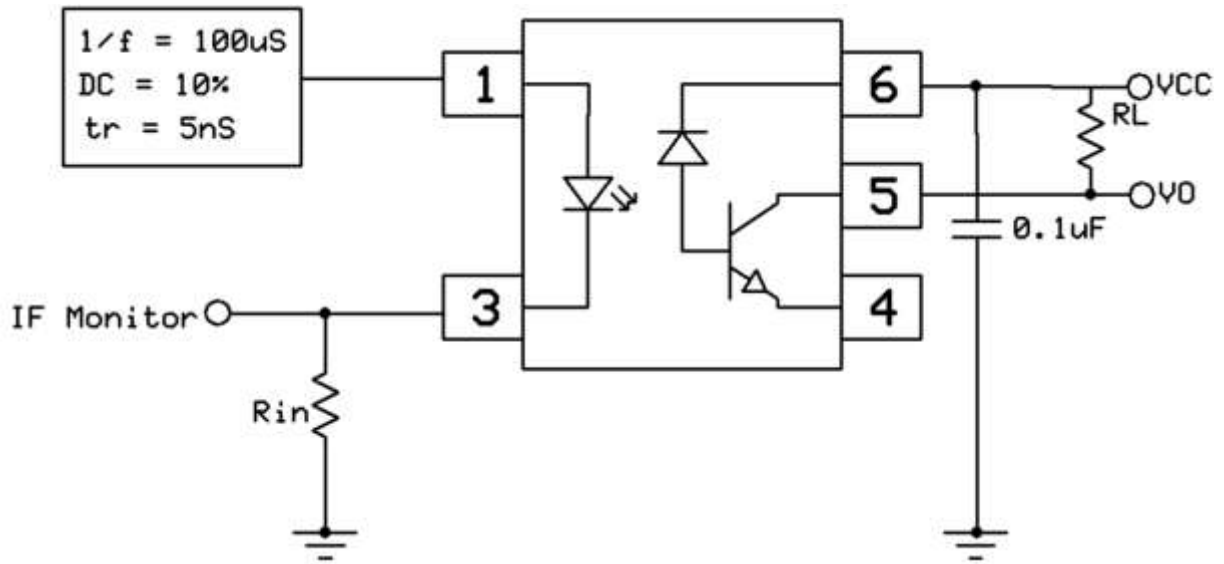

Switching Time Test Circuit

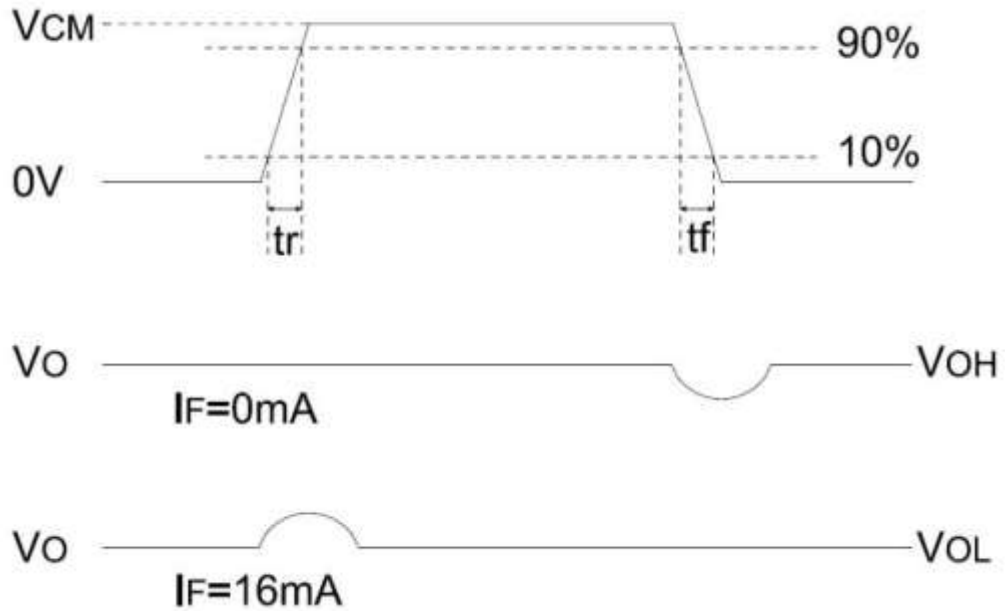
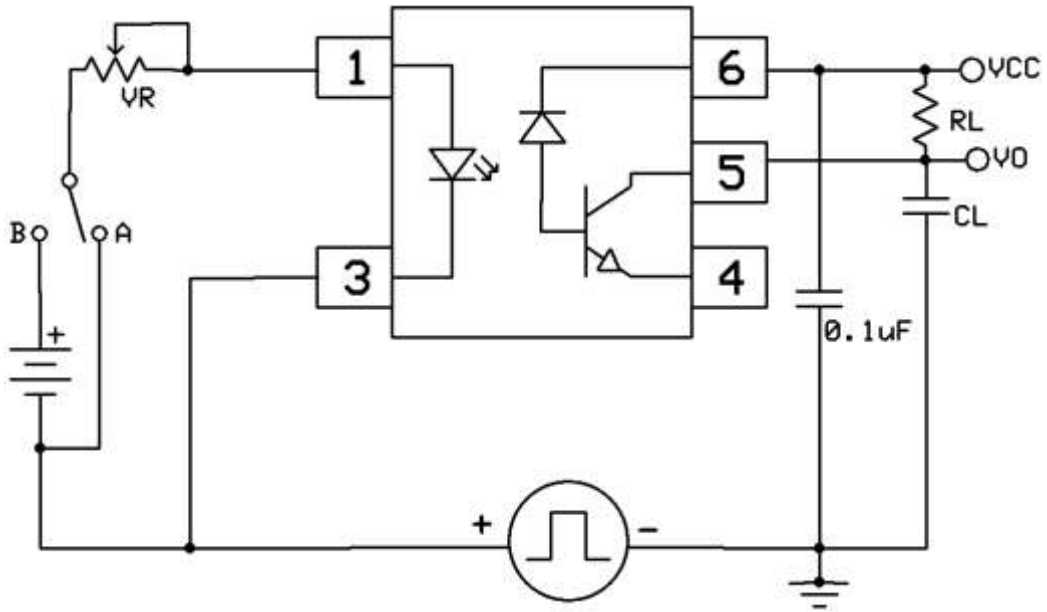

CMR Test Circuit

Solder Profile & Footprint

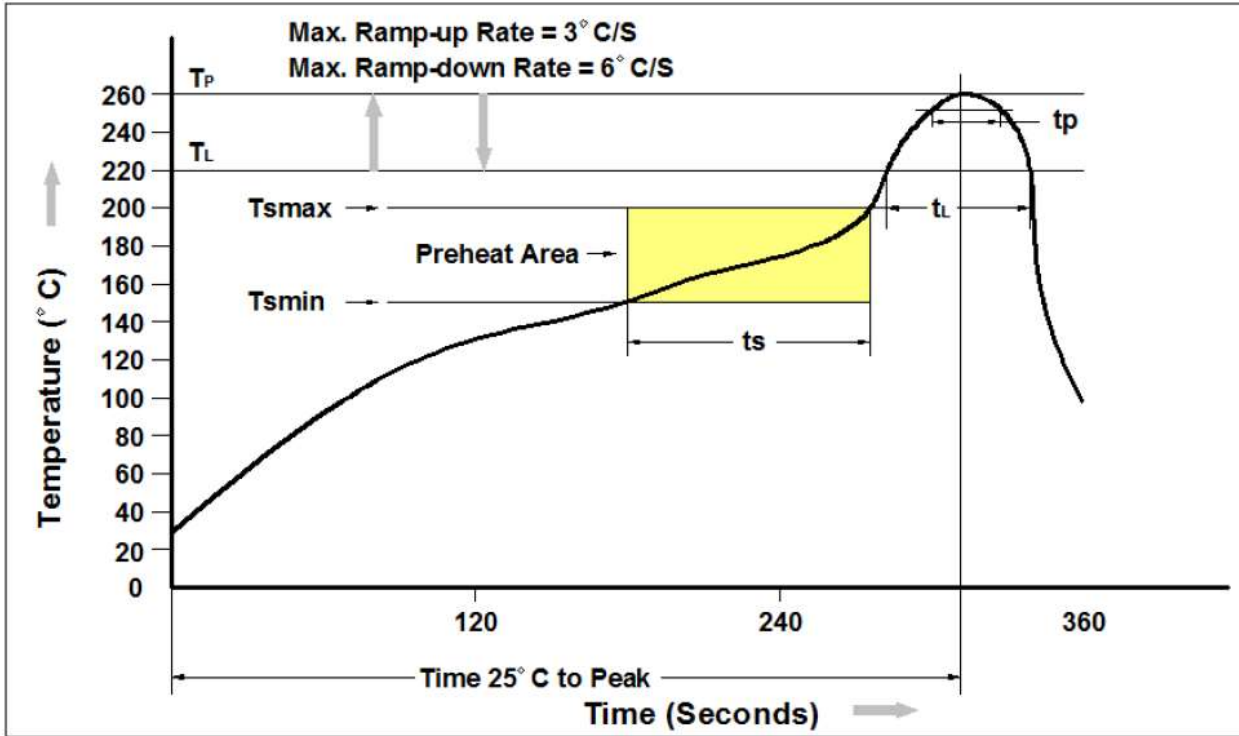

Profile Feature	Pb-Free Assembly Profile
Temperature Min. (T _{smin})	150°C
Temperature Max. (T _{smax})	200°C
Time (t _s) from (T _{smin} to T _{smax})	60-120 seconds
Ramp-up Rate (t _L to t _P)	3°C/second max.
Liquidous Temperature (T _L)	217°C
Time (t _L) Maintained Above (T _L)	60 – 150 seconds
Peak Body Package Temperature	260°C +0°C / -5°C
Time (t _P) within 5°C of 260°C	30 seconds
Ramp-down Rate (T _P to T _L)	6°C/second max
Time 25°C to Peak Temperature	8 minutes max.

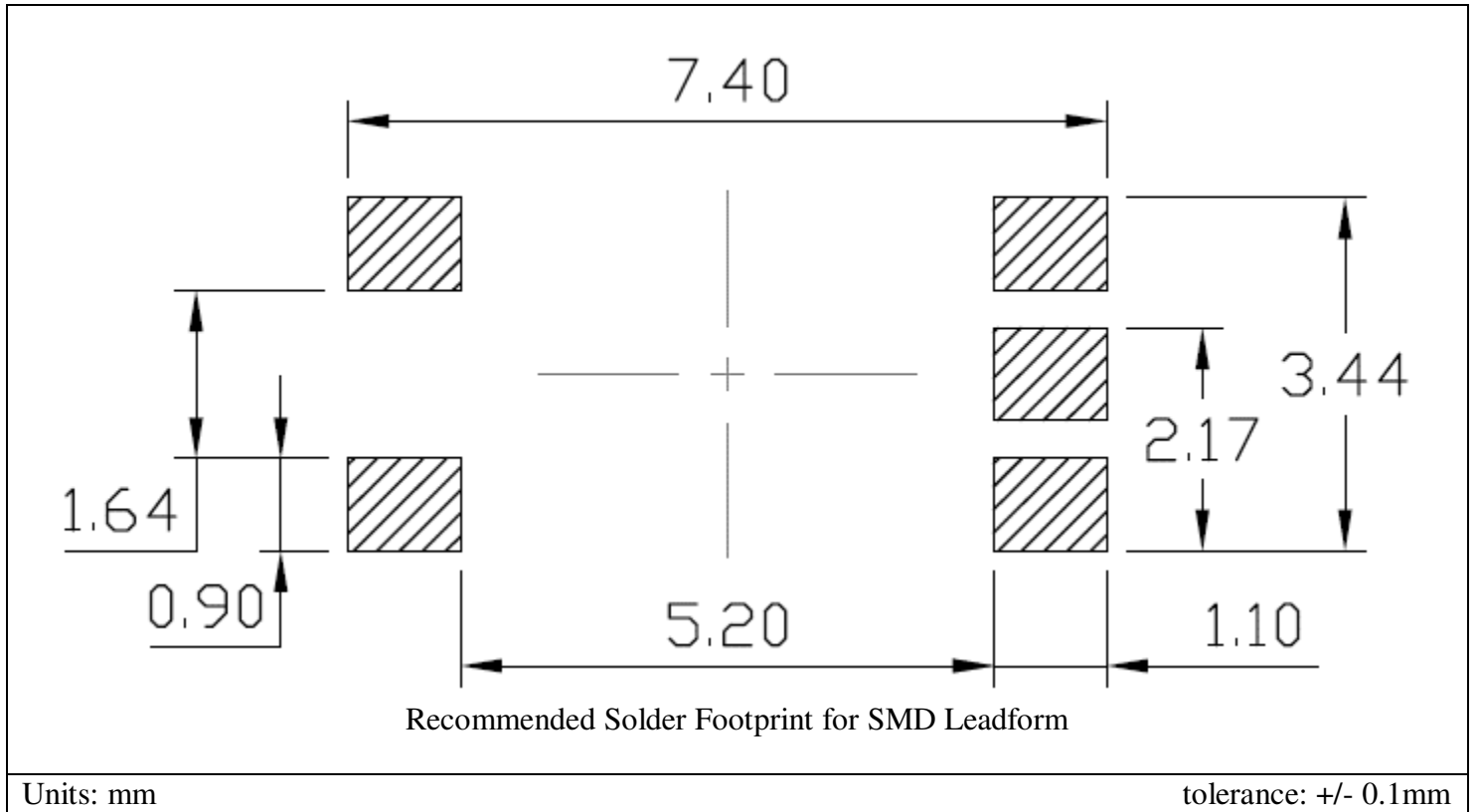

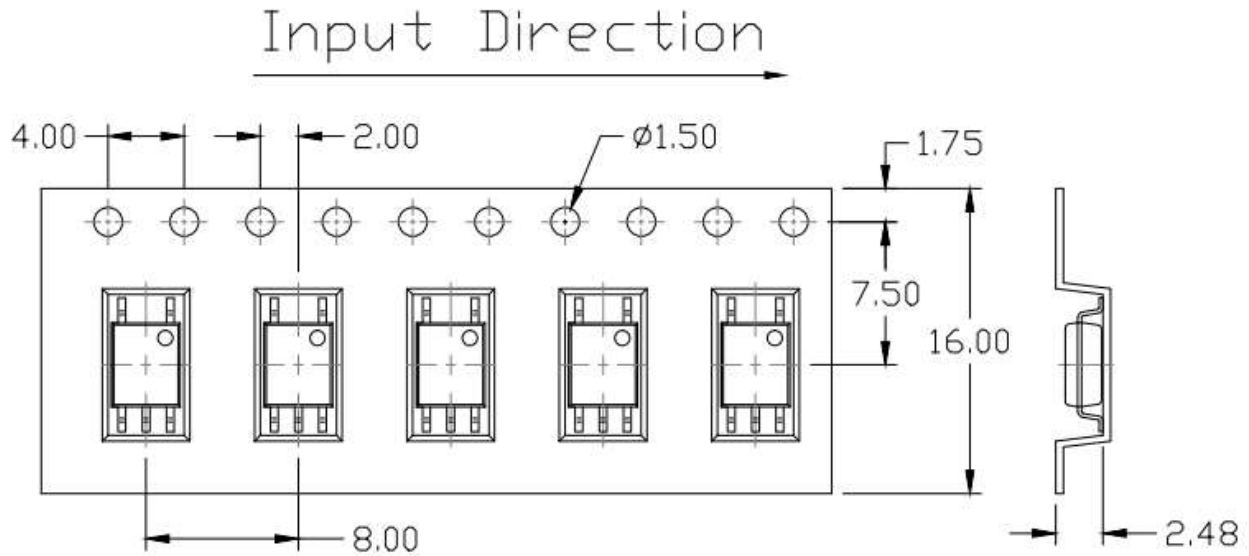
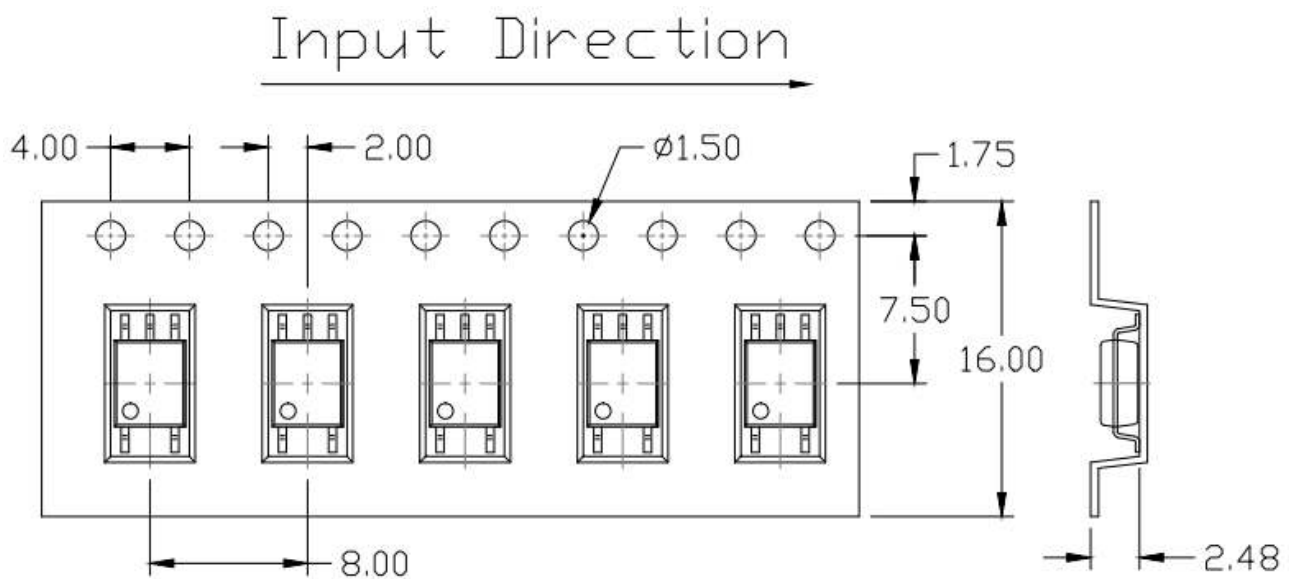
Packing & Labeling**Tape Dimension:****Option T1****Option T2**

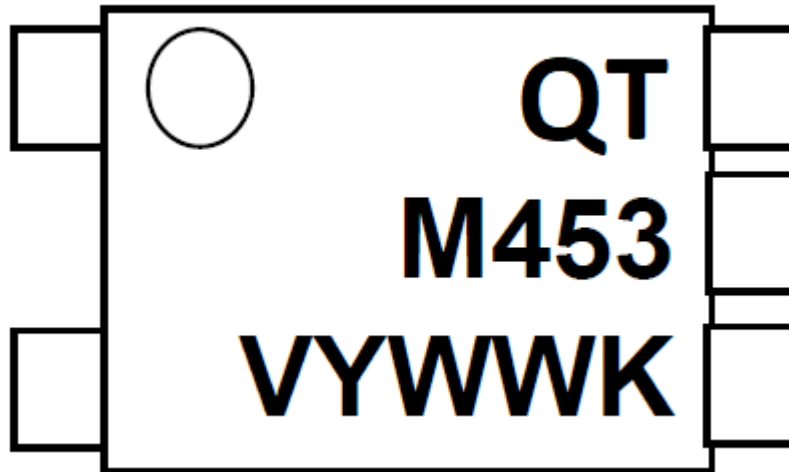
Device Marking

QT = QT-Brightek Corporation
 M= Mini-Flat Package
 453 = part number
 Y = Year
 WW = Week
 V = VDE Option
 K= Manufacturing code

Ordering Information

QTM45X(V)(Z)
 X = Part number (X=2 or 3)
 V = VDE option (V or None)
 Z = Tape and reel option (T1 or T2)

Option	Description	Quantity
T1	Surface Mount Lead Forming – with Option 1 Taping	3000 pcs/ reel
T2	Surface Mount Lead Forming – with Option 2 Taping	3000 pcs/ reel



Revision History

Description:	Revision #	Revision Date
Initial release of QTM452_453	1.0	02/12/2018

Disclaimer

QT-BRIGHTTEK reserves the right to make changes without further notice to any products herein to improve reliability, function or design. QT-BRIGHTTEK does not assume any liability arising out of the application or use of any product or circuit described herein; neither does it convey any license under its patent rights, nor the rights of others.

Life Support Policy

QT-BRIGHTTEK’s products are not authorized for use as critical components in life support devices or systems without the express written approval of QT-BRIGHTTEK. As used herein:

1. Life support devices or systems are devices or systems which, (a) are intended for surgical implant into the body, or (b) support or sustain life, and (c) whose failure to perform when properly used in accordance with instructions for use provided in the labeling, can be reasonably expected to result in a significant injury of the user.
2. A critical component in any component of a life support device or system whose failure to perform can be reasonably expected to cause the failure of the life support device or system, or to affect its safety or effectiveness.