

\*ACTION PIN AND AMPPOWER are registered trademarks of AMP Incorporated.

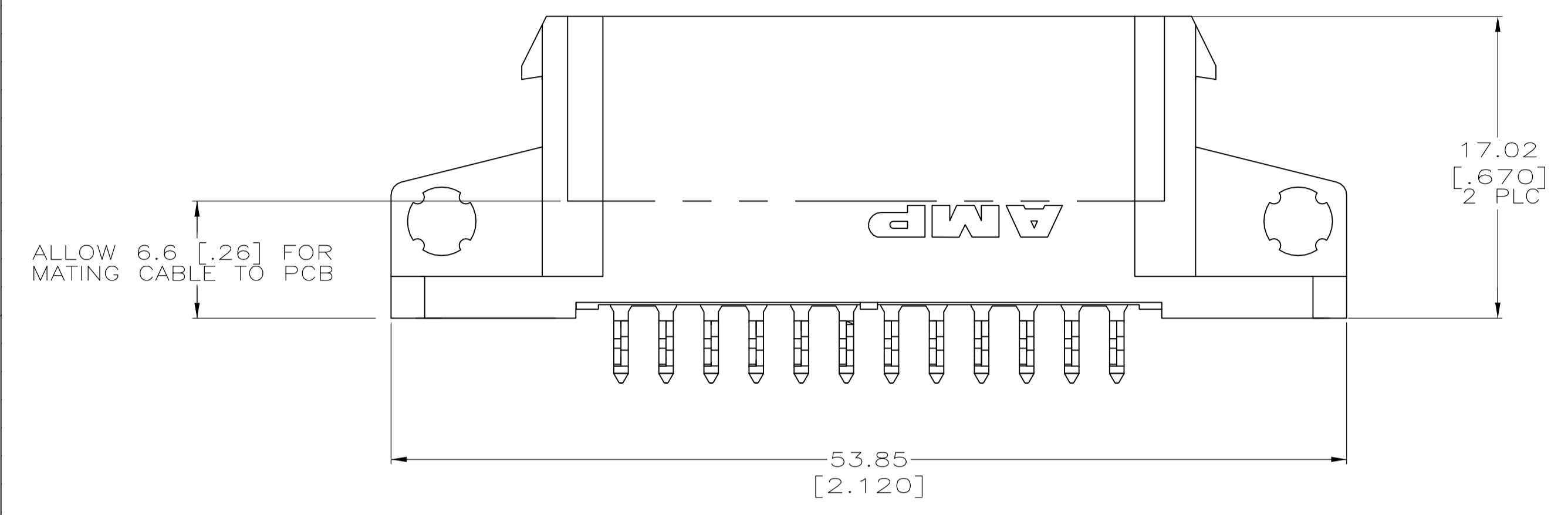

- 1 HOLE DIAMETER AFTER PLATING.
- 2 FOR 2.36 [.093] AND THICKER PCB'S.
- 3 HOUSING MATERIAL: POLYESTER  
CONTACT MATERIAL: COPPER ALLOY
- 4 CONTACT FINISH: SILVER ON MATING END,  
TIN ON SOLDER TAILS,  
NICKEL ALL OVER.

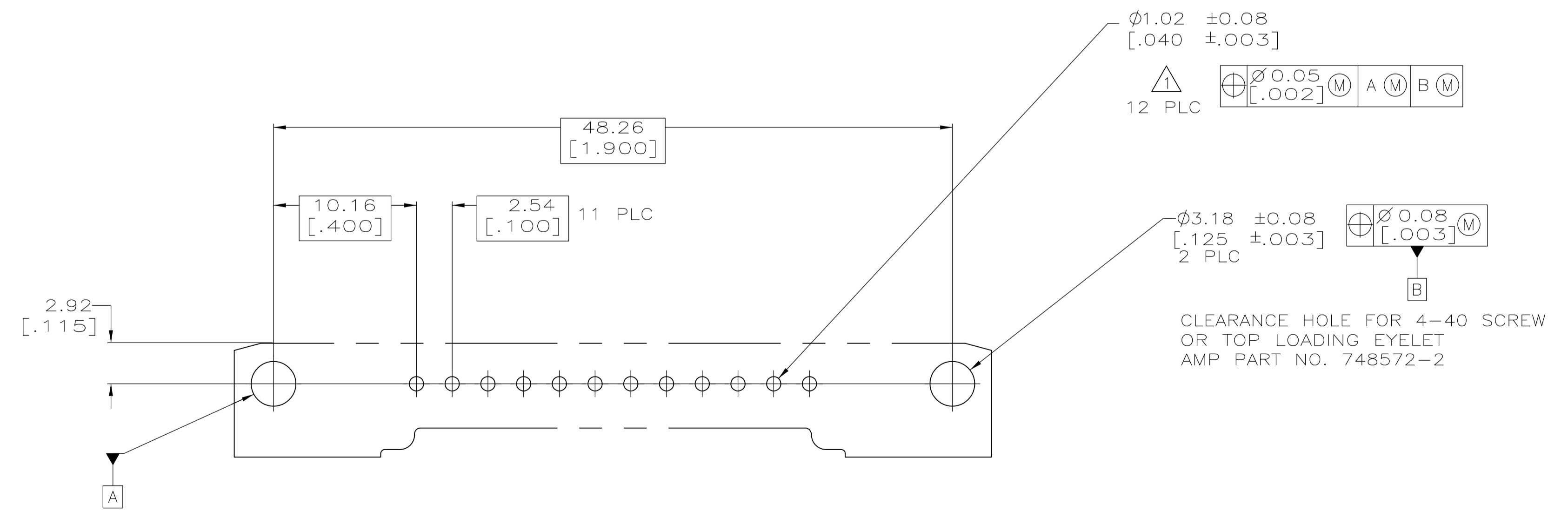
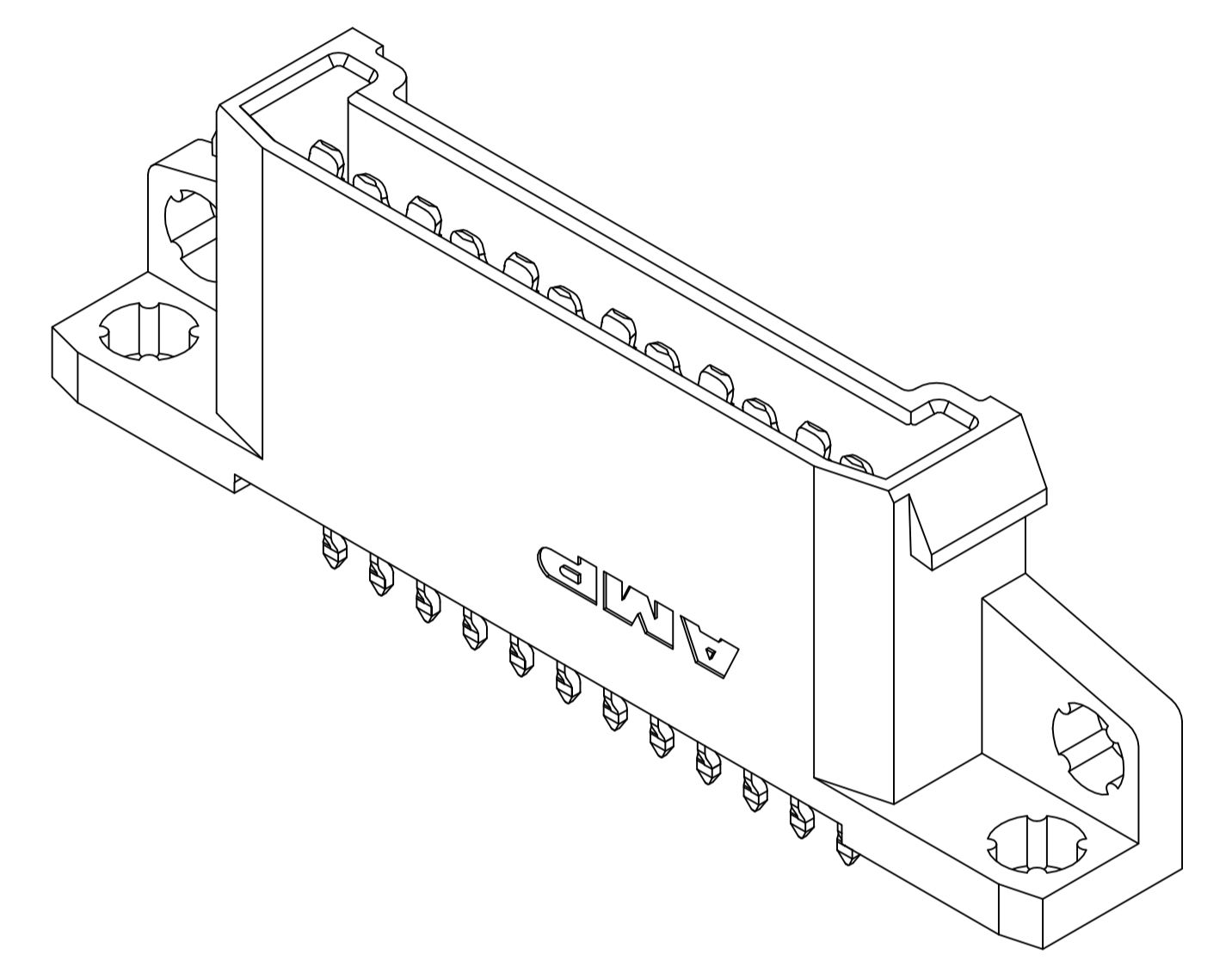
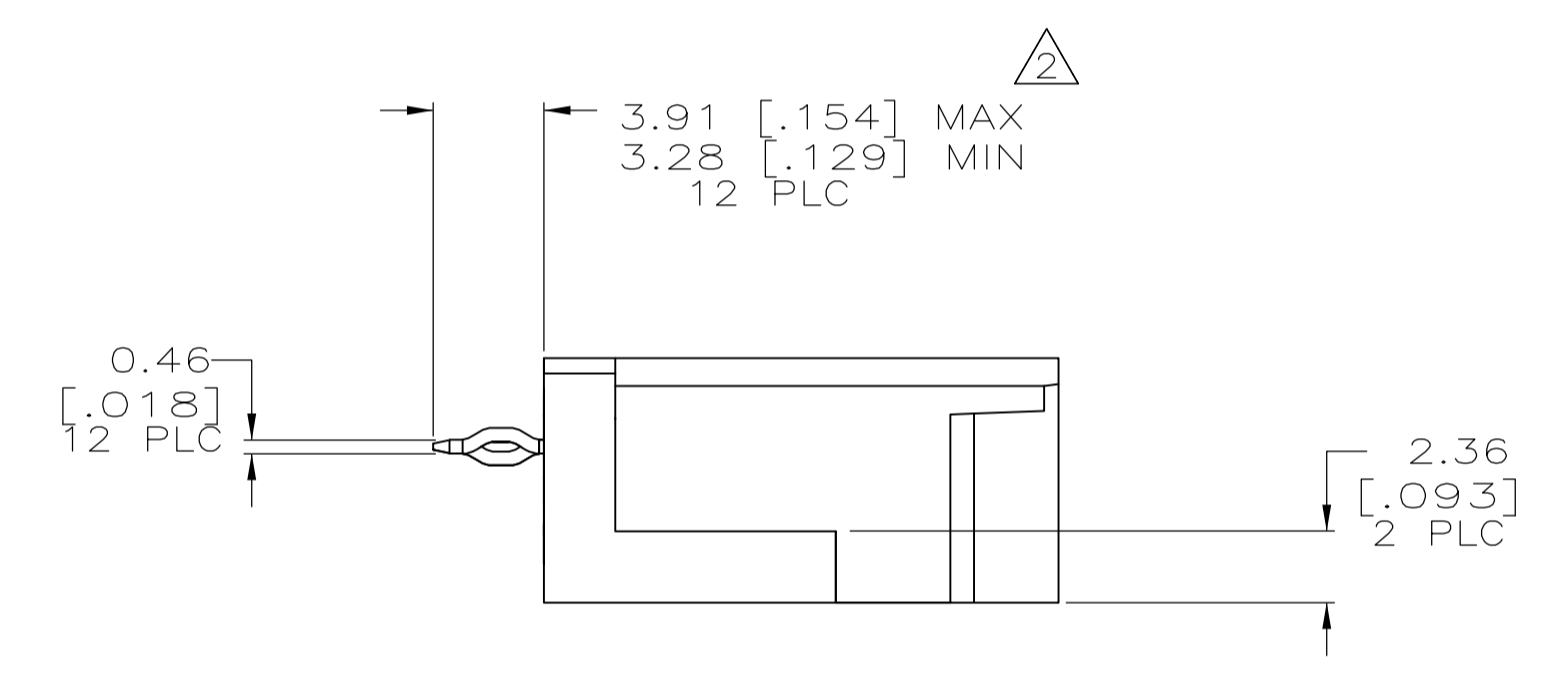
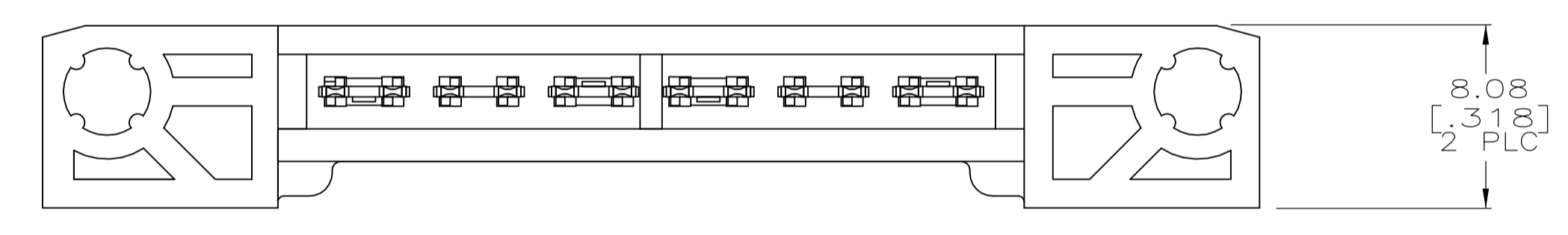

5765271-1  
PART NUMBER

THIS DRAWING IS A CONTROLLED DOCUMENT. DIMENSIONING AND TOLERANCING PER ASME Y14.5M-2009.		DIN C. VALENTINE 05NOV2012	TE Connectivity
DIMENSIONS: mm [INCHES]		CHK D. ORRIS 05NOV2012	
TOLERANCES UNLESS OTHERWISE SPECIFIED:		APVD D. ORRIS 05NOV2012	NAME
0 PLC ± -		PRODUCT SPEC	AMPPOWER Wave Crimp System
1 PLC ± -		APPLICATION SPEC	ACTION PIN HDR ASSY, VERT
2 PLC ± 0.25 [.01]		SIZE	108-1410
3 PLC ± 0.13 [.005]		SCALE	2.54 CENTERLINES
4 PLC ± -		WEIGHT	114-49005
ANGLES ± -		CUSTOMER DRAWING	A1 00779 C=5765271
MATERIAL	FINISH	RESTRICTED TO	SCALE 4:1 SHEET 1 OF 1 REV A