

LOC	DIST	REVISIONS			
P	CHR	DESCRIPTION	DATE	DWN	APVD
B		ECO-06-011837	20MAY2006	LAM	JW

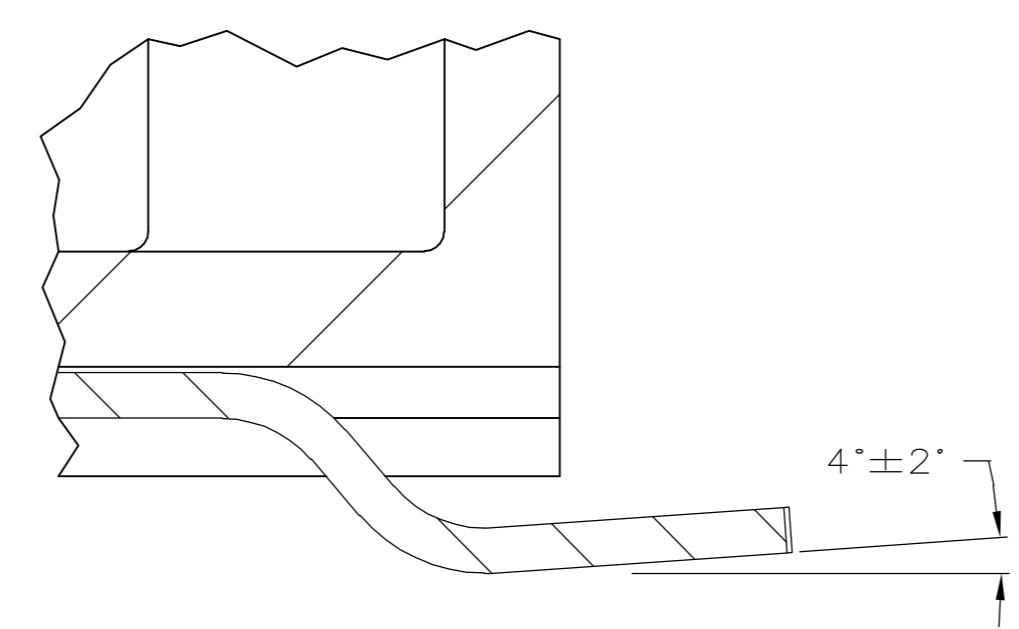

DETAIL A
SCALE 20:1

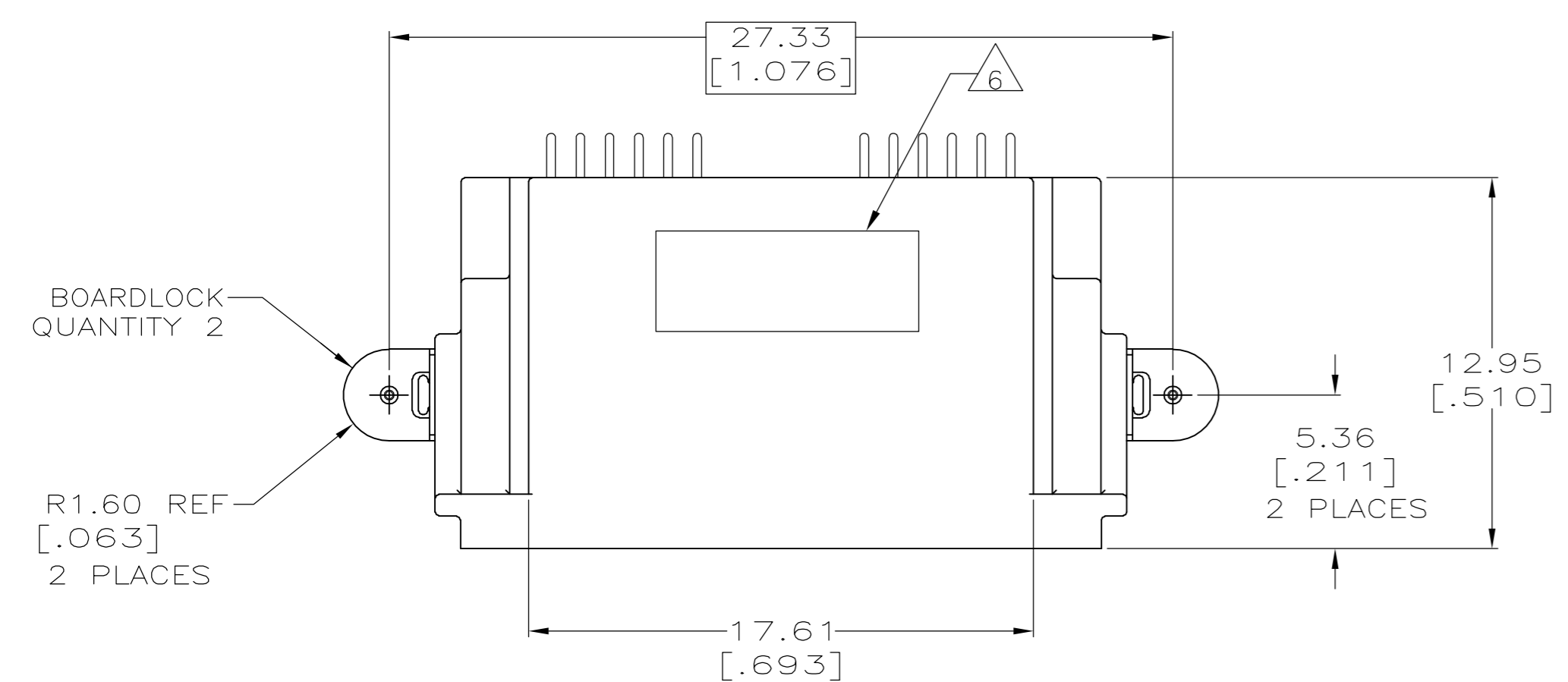
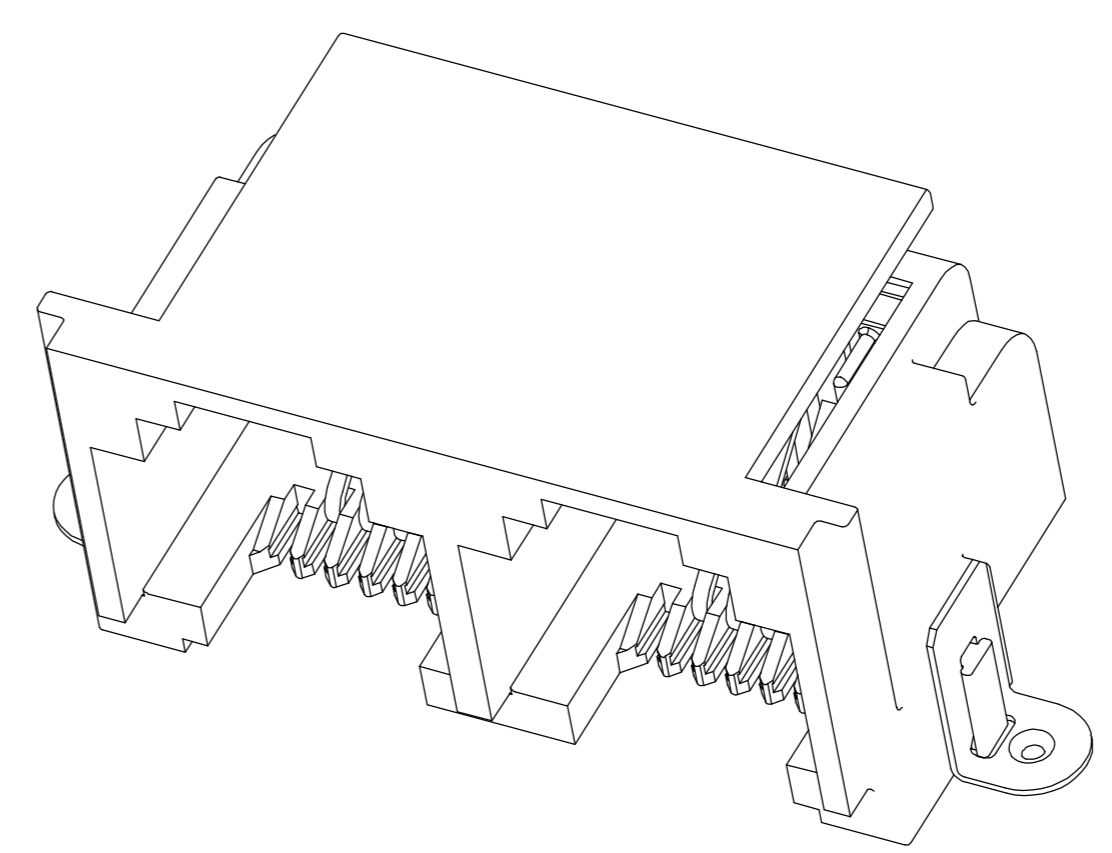

- MATERIAL: HOUSING - HIGH TEMPERATURE THERMOPLASTIC, SEE TABLE FOR COLOR.
 TERMINALS - 0.3[.012] THICK COPPER ALLOY PLATED WITH 1.27μm[.000050] MINIMUM GOLD IN LOCALIZED CONTACT AREA, 2.5μm[.000100] MINIMUM MATTE TIN ON TERMINATION END, OVER 1.27μm[.000050] MINIMUM NICKEL OVER THE ENTIRE TERMINAL.
 BOARDLOCK - BRASS, 1/2 HARD, 2.54μm[.000100] MINIMUM MATTE TIN OVER 1.27μm[.000050] MINIMUM NICKEL.

- ② JACK CAVITY CONFORMS TO FCC RULES AND REGULATIONS, PART 68 SUBPART F.
- ③ DATUM ESTABLISHED BY CUSTOMER.
- ④ PACKAGING TAPE AND REEL:(PER EIA 481 SPEC)
 TAPE - 44mm[1.73] WIDE
 POCKET PITCH - 24mm[.945]
 CORRUGATED REEL DIAMETER - 560mm[22.0]
 PIECES/REEL - 650
- ⑤ PACKAGING TAPE AND REEL:(PER EIA 481 SPEC)
 TAPE - 44mm[1.73] WIDE
 POCKET PITCH - 24mm[.945]
 PLASTIC REEL DIAMETER - 330mm[13.0]
 PIECES/REEL - 200
- ⑥ MANUFACTURING DATE CODE LOCATED APPROXIMATELY AS SHOWN. FIRST 2 DIGITS ARE YEAR, SECOND 2 DIGITS ARE WORK WEEK, AND LAST DIGIT IS DAY OF THE WEEK

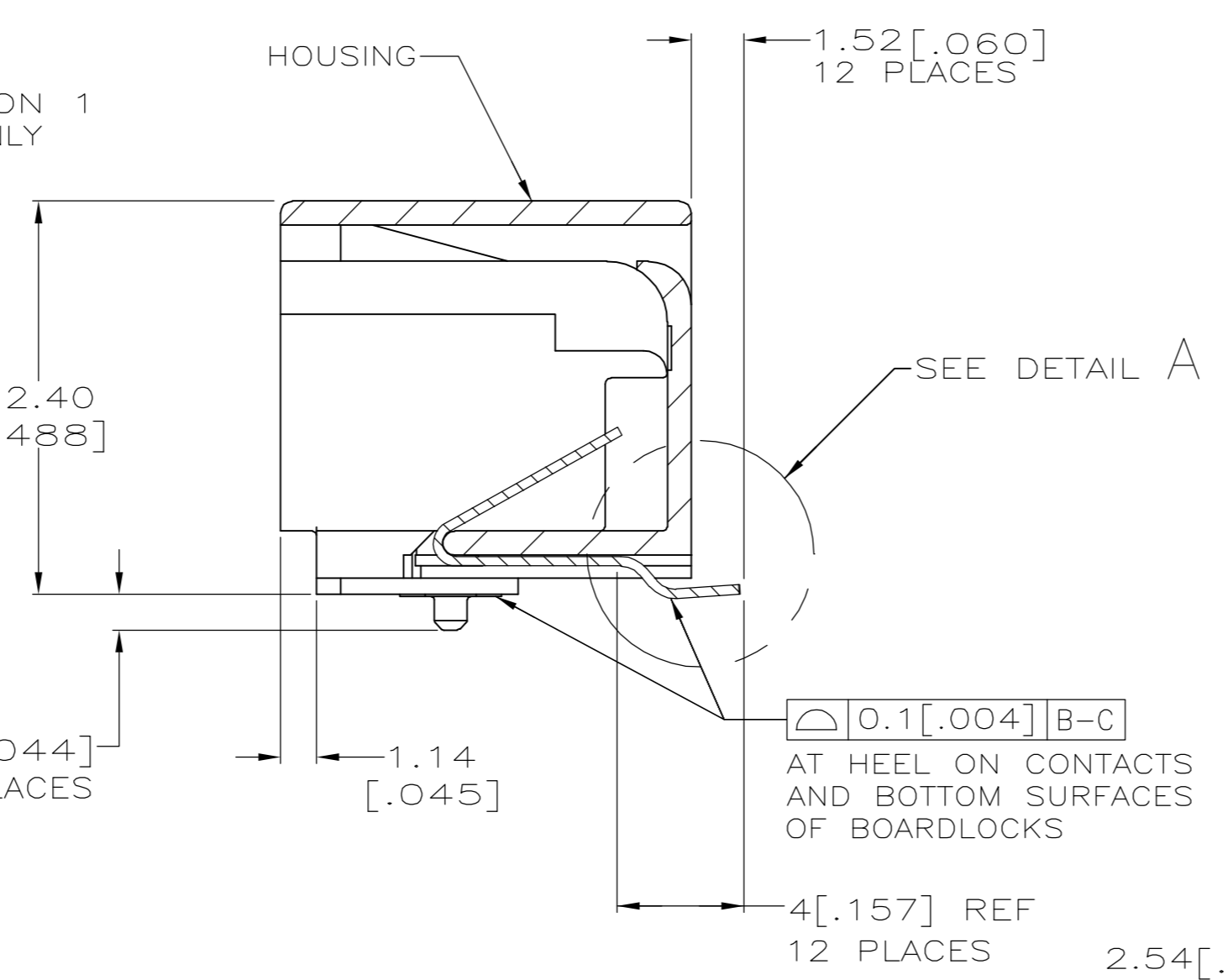
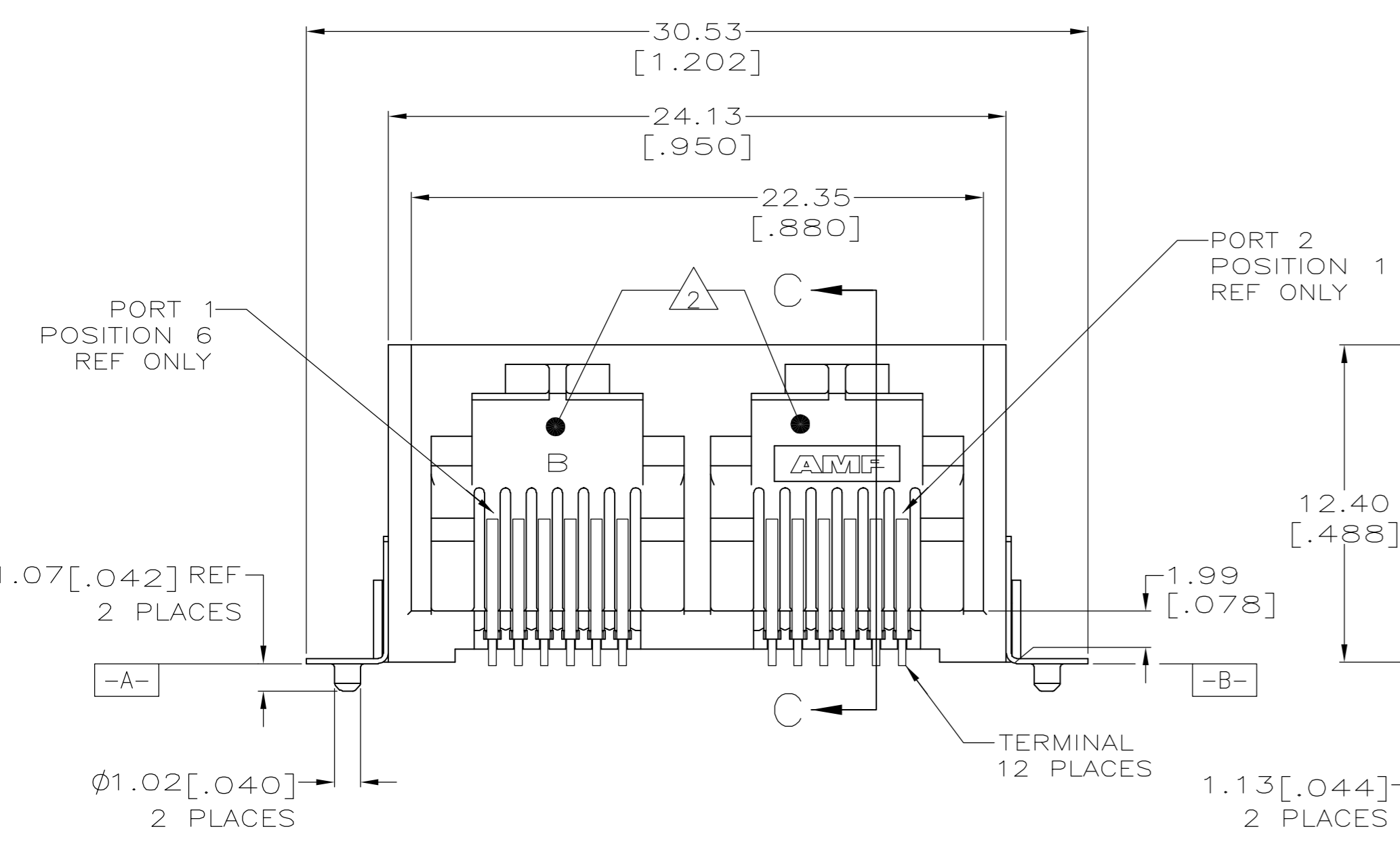

SECTION C-C

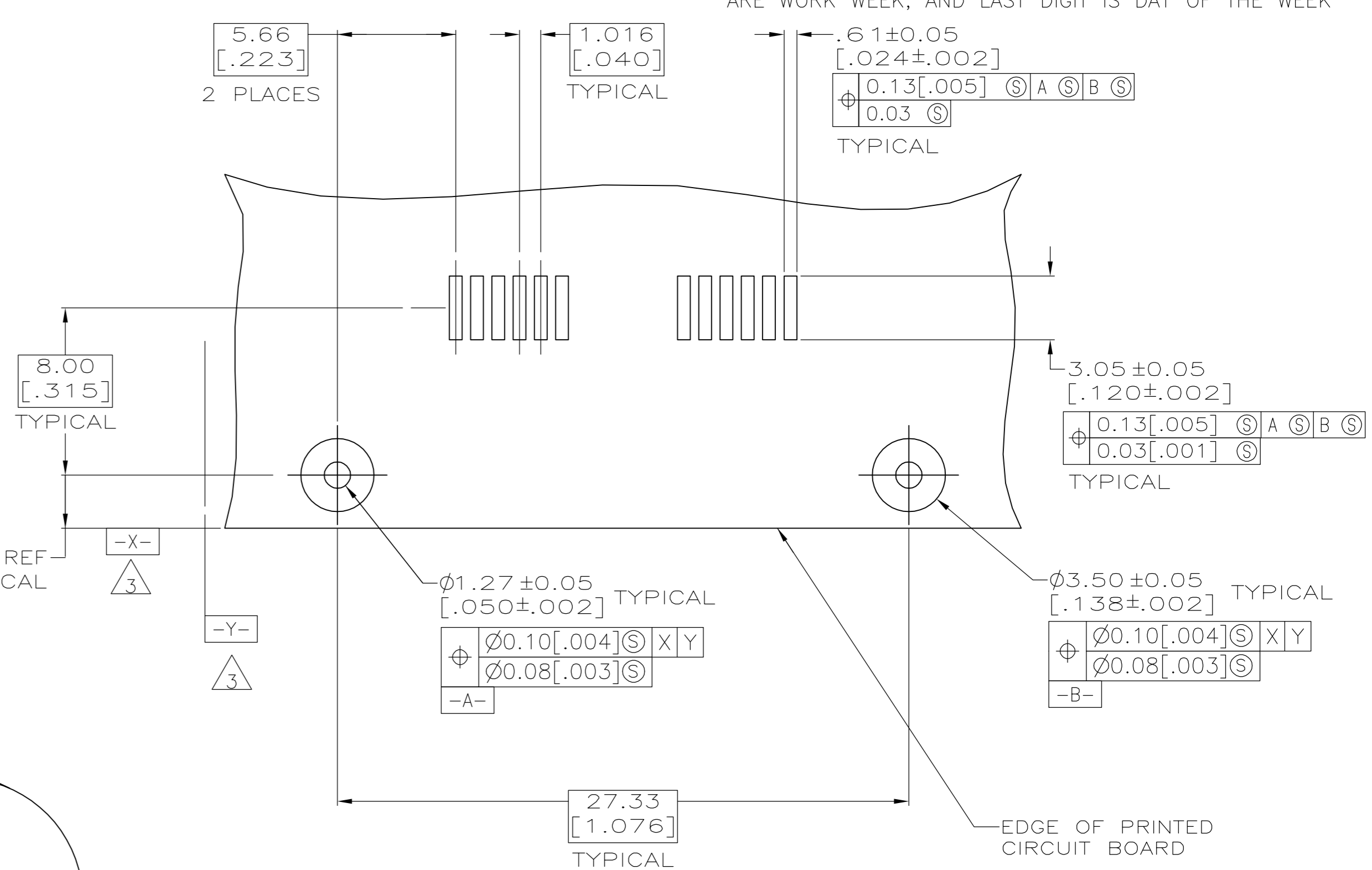

RECOMMENDED PRINTED CIRCUIT BOARD LAYOUT
 COMPONENT SIDE - VIEWED FROM TOP
 SCALE 5:1

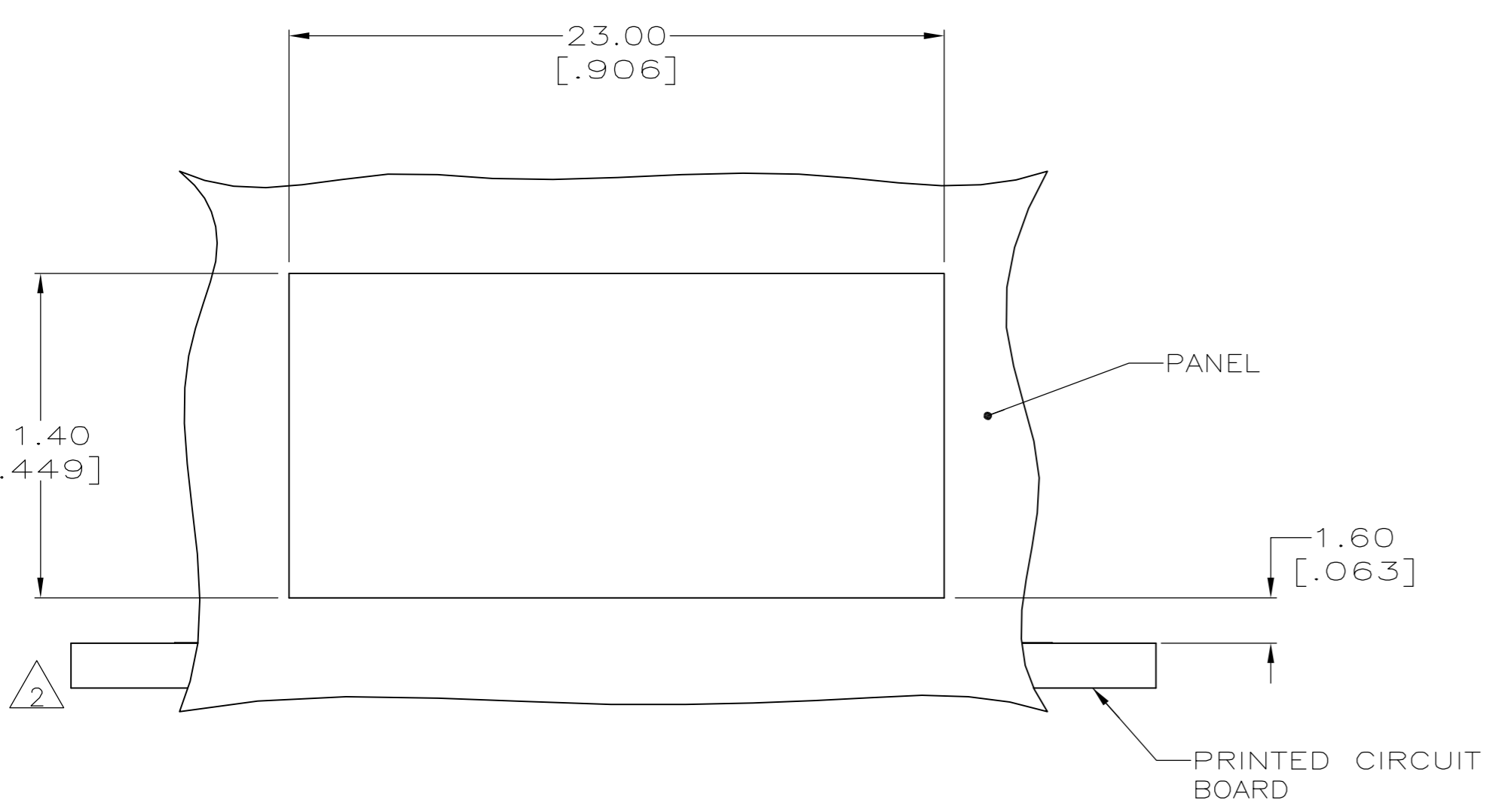

RECOMMENDED PANEL CUTOUT
 SCALE 5:1

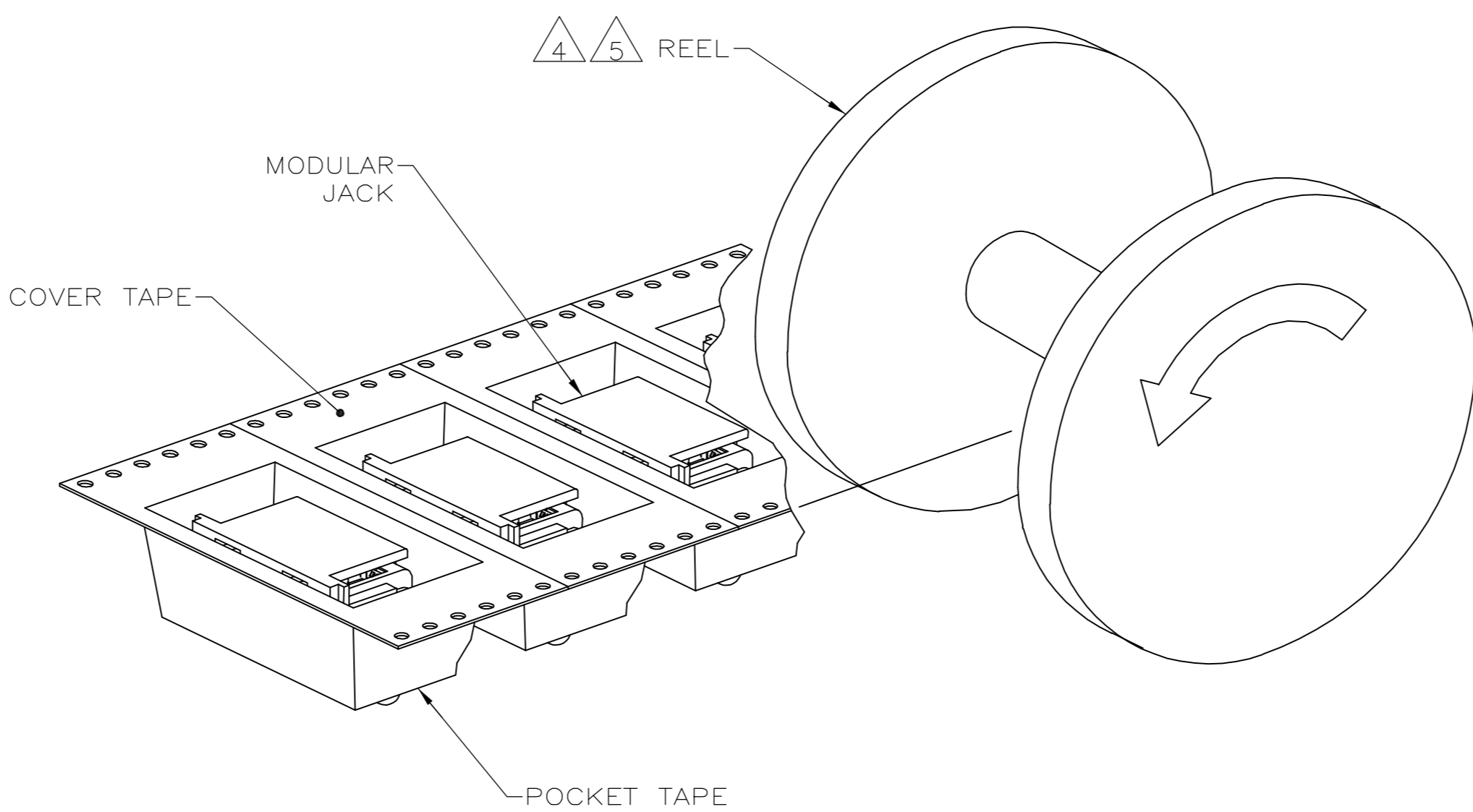

MARKING	COLOR	PACKAGING	PART NUMBER
NONE ②	GRAY	④	5406903-4
③	GRAY	⑤	5406903-2
⑥	GRAY	④	5406903-1

THIS DRAWING IS A CONTROLLED DOCUMENT.		DWN J. ALCORTA - 16JUN2005	tyco Tyco Electronics Corporation
DIMENSIONS: mm [INCHES]		DCK J. WESTMAN - 16JUN2005	Harrisburg, PA 17105-3608
TOLERANCES UNLESS OTHERWISE SPECIFIED:		APVD S. FLICKINGER - 16JUN2005	NAME MODULAR JACK ASSEMBLY, 6/6, 2 PORT, SURFACE MOUNT, RIGHT ANGLE, WITH PANEL STOPS
0 PLC ± -	1 PLC ± -	PRODUCT SPEC 108-1689	SIZE 114-6040
2 PLC ± 0.13[.005]	3 PLC ± -	APPLICATION SPEC	WEIGHT 2.2 GRAMS
4 PLC ± -	ANGLES ± -	FINISH SEE NOTE 1	RESTRICTED TO A1 00779 ©=5406903
MATERIAL SEE NOTE 1	FINISH SEE NOTE 1	SCALE 5:1	SHEET 1 OF 1
CUSTOMER DRAWING		REV B	