



Made in the United States of America

Wrist Straps Grounding, Testing and Maintenance

Wrist Straps per ANSI/ESD S20.20

“All personnel shall be bonded or electrically connected to the grounding / equipotential bonding system when handling ESDS [ESD sensitive] items.” “When personnel are seated at ESD protective workstations, they shall be connected to the grounding/equipotential bonding system via a wrist strap system.” [ANSI/ESDS20.20-2007 sections 8.1 and 8.2]

Location of Wrist Strap Ground Point

Wrist straps, ESD worksurfaces, and floor mats are to be grounded to remove electrostatic charges connected to a common point ground. The common point ground should be connected with one ground cord to the “green wire” equipment ground.

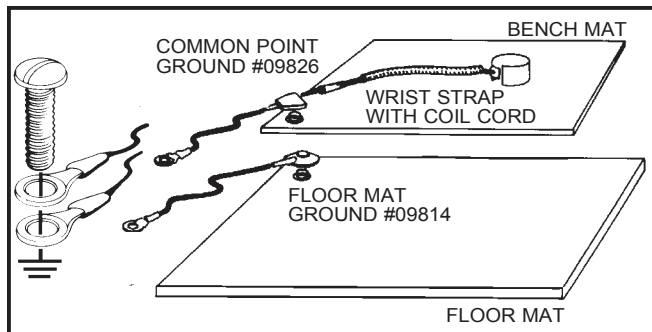

Figure 1. Common point ground for each workstation

This may be accomplished in a variety of ways utilizing a common point ground block, a ground bus, or connecting directly to the nearest AC “green wire” equipment ground point. In a properly wired building, the nearest reliable equipment ground point will be ground or the center screw of the standard 110 VAC electrical outlet.

Each ESD workstation must be individually grounded to the ground bus or “green wire” equipment ground. Do not wire worksurfaces or other ESD devices in series or “daisychain” them. This can create unknown higher resistance to ground. For a more detailed discussion of ESD grounding see Desco technical bulletin [TB-2007](#). For instructions on grounding Desco worksurface mats see technical bulletin [TB-2000](#).

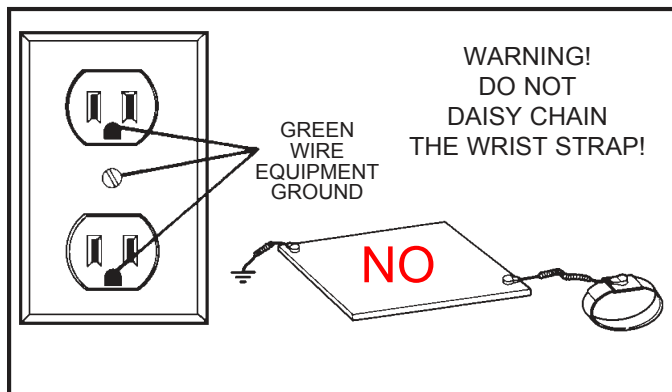

Figure 2. “Green wire” equipment ground

Test The Ground Before You Use It And Periodically Thereafter

Do not assume that any AC electrical outlet is properly wired. Even if it was originally wired correctly it can become ungrounded due to corrosion and wear. Test the ground you intend to use before you hook up. We suggest using Desco's item [98132](#) AC Outlet Analyzer and Wrist Strap Tester.

A Banana Jack Is Recommended

Almost all wrist strap manufacturers terminate wrist ground cords with banana plugs. This is because the banana plug and jack have proven to be a fast and reliable way to attach to ground. If you must use another method such as snaps or alligator clips, due to your particular environment, be sure to test the connections often.

Note: Many wrist strap users clip the wrist cord to the edge of an ESD mat. This process is not recommended as it can increase the total system resistance to ground to over the 35 megohm required limit of ANSI/ESD S20.20. “Wrist strap ground cords must be connected to a groundable point or an equipotential bonding point. Do not connect to a snap on a dissipative mat unless it is the groundable point for the mat. Do not clip a wrist strap to the edge of a dissipative mat.” [ESD Handbook TR20.20 section 5.3.2.7] Best industry practice is that ESD Ground Connections should be firm fitting connecting devices such as metallic crimps, snaps and banana plugs shall be connected to designated ground points. Use of alligator clips is not recommended.

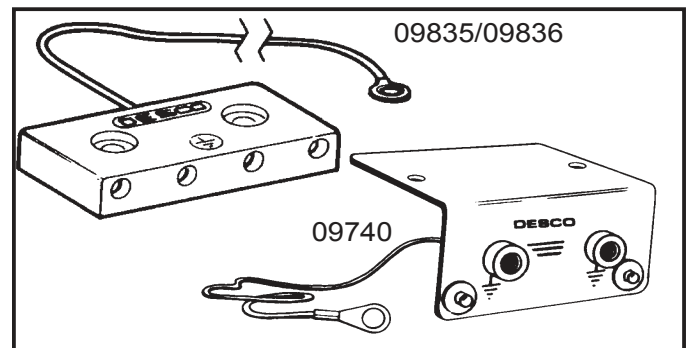

Figure 3. Desco's [09740 / 09741](#) dual bench mount and [09835 / 09836](#) quad common point ground cord are two easy ways to provide multiple banana jacks at any workstation.

Compliance Verification of the Ground System

Set up a schedule to be sure that all ESD grounds are inspected and tested periodically, every six months for example.

Testing the Wrist Strap

The best test of the wrist strap system is while it is worn. This includes all three components: the wrist band, the ground cord (including current limiting resistor), and the interface with the wearer's skin.

"Wrist straps should be tested periodically. The frequency of testing, however, is driven by the amount of risk exposure that can occur between tests. For example, what is the quantity of product handled between test periods?"

Because wrist straps have a finite life, it is important to develop a test frequency that will guarantee integrity of the system. Typical test programs recommend that wrist straps that are used daily should be tested daily. However, if the products that are being produced are of such value that knowledge of a continuous, reliable ground is needed, and then continuous monitoring should be considered or even required. Data taken from the test program will ultimately allow the user to make the choice of how often the wrist strap should be checked and which wrist straps have the most useful service life." [ESD Handbook ESD TR20.20-2008 Wrist Strap section 5.3.2.4.4 Test Frequency]



Figure 4. Wrist strap testers

Desco has several wrist strap testers available for this purpose. For more information ask for specification technical drawings or technical bullitens by item number. If you obtain a high or low reading from the tester you should stop work and test the wristband and coil cord individually to find out which item has failed. ESD lotion can be applied to the wrist area to improve the user's interface with the wearer's skin. Replace the bad component and test the system again. Obtain a "Pass" reading before beginning work.

Per ANSI/ESD S20.20-2007 section 7.3 "Compliance verification records shall be established and maintained to provide evidence of conformity to the technical requirements. The test equipment selected shall be capable of making the measurements defined in the Compliance Verification Plan."

Cleaning

For proper operation, the wrist strap, especially the wristband strip, must be kept clean. All wristbands should be cleaned with a mild detergent on a periodic basis. Be sure that metallic expansion wrist bands are thoroughly dried to prevent corrosion.

Woolite™ works well. Liquid detergents are better than dry in that there is less caking and frictional wear. Launder elastic wrist band strips in cool or warm water, tumble dry with low heat or hang dry. DO NOT BLEACH.

Wrist Strap silver fibers are sensitive to heat and should not be exposed to laundering heat in excess of 120°F. Use only non-ionic softeners and detergents when laundering.

Size Adjustment of Wristbands

Elastic Adjustable Wristbands

The elastic adjustable band is designed to be adjusted to the proper size to fit each individual wearer. After adjustment it can be used as a fixed size band. It is only necessary to adjust the size once.

1. Place the wristband on the wrist.

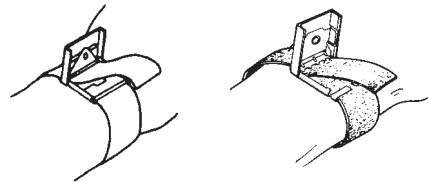

2. Open the clasp by pulling upward on the "tail" of material that extends out from the clasp.

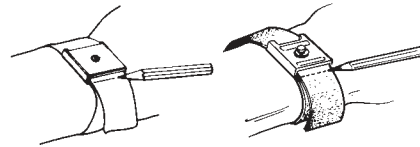

3. Tighten or loosen the elastic material through the clasp until the wristband fits snugly but comfortably.

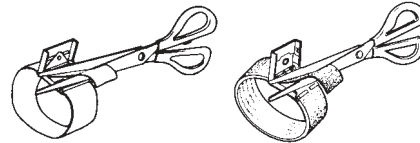

4. We recommend that you close the clasp and wear the band with the excess tail extended for a day to be sure the adjustment is snug, comfortable, and has the proper electrical contact with the skin before cutting.
5. Test the wrist strap system to be sure of proper electrical resistance and skin contact. Use the procedure described under "testing".
6. When you are ready to cut off excess material, mark with a pencil where excess material is to be trimmed.
7. Remove band from wrist. Open clasp. Cut off excess material about 1/4" short of pencil mark so that the end of material is concealed by the cap. This will eliminate the possibility of exposed frayed ends.
8. Close clasp and use as a fixed elastic wristband.

Replacement of Elastic Material

For use with [09028](#), [09069](#), and [09070](#) only. Order item number [09029](#) from Desco for a wristband replacement strip. For use with [09100](#), [09104](#), [09130](#), [09105](#), and [09108](#) only. Order item number [09140](#) from Desco for a Jewel® wristband replacement strip. When the elastic material becomes worn out, it can be easily replaced. To replace, simply open the clasp as described under "Adjustment". Remove the fabric from the clasp. Note that the second end of the material is secured to the clasp by a smaller camlock. Open the small camlock (A small screwdriver is helpful.) Remove the worn wristband strip and replace it with the [09029](#). Be sure no material extends to the end of the lever arm of the small camlock. This will cause the clasp to close improperly and not hold firmly.

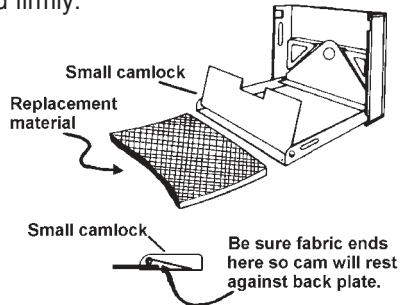

Metal Expansion Wristbands

1. Insert the link end of the wristband into the slotted opening on the cap. Insert it at a downward angle to allow the links to slide inside the channel in the backplate.

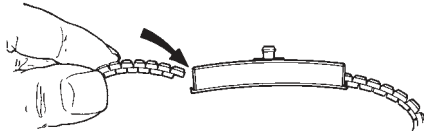

2. Change the size of the band by sliding the links in or out of the stainless steel backplate. For extra small users you can cut off excess links with cutters.

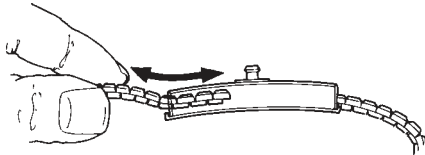

3. Lock the links into place by pulling down on the band, seating the band securely over the lip on the edge of the backplate.

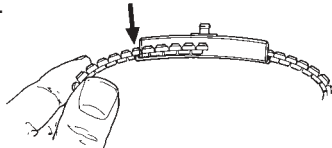

4. Test the wrist strap system to be sure of proper electrical resistance and skin contact. Use the procedure described under "Testing" section on reverse side.

Hook and Loop Wrist Strap

This wristband consists of a hook and loop band with a D-ring buckle, a conductive strip for static charge dissipation, and a 4mm snap stud. The D-ring enables the wearer to cinch the band for a secure fit. The band will adjust to fit any size wrist. Contact with the wearer is established through a conductive teflon tab sewn to the inside of the band.

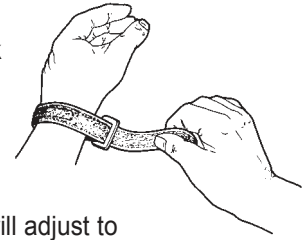

1. Attach wrist strap on wrist so that the black conductive band makes contact with skin.
2. Pull strap through D-ring and cinch the band for a snug fit.
3. Test the wrist strap system to be sure of proper electrical resistance and skin contact. Use the procedure described under "Testing The Wrist Strap" on page 1.

Note: Desco wrist straps and coil cords are UL Listed for safety. However, this product is not recommended for use on equipment with operating voltage exceeding 250 VAC.

CAUTION: The ESD Series is for electrostatic control. It will not reduce or increase your risk of receiving electric shock when using or working on electrical equipment. Follow the same precautions you would use without wrist straps, including:

- Make certain that equipment having a grounding type plug is properly grounded.
- Make certain that you are not in contact with grounded objects other than through the ESD Series.

Limited Warranty, Warranty Exclusions, Limit of Liability and RMA Request Instructions

See Desco's Terms and Conditions -

<http://desco.descoindustries.com/TermsAndConditions.aspx>